

brother

自動本縫玉縁機
自動本縫玉縁機 〈フラップ付用〉

BAS-605 BAS-606

AUTOMATIC LOCKSTITCH POCKET WELT SEWER
AUTOMATIC LOCKSTITCH POCKET WELT SEWER <FOR FLAP ATTACHMENT>

PASPELTASCHENAUTOMAT MIT GROSSEM GREIFER FÜR TASCHEN OHNE PATTE
PASPELTASCHENAUTOMAT MIT GROSSEM GREIFER FÜR TASCHEN MIT PATTE

AUTOMATE POCHE PASSEPOILEES - POINT NOUE
AUTOMATE POCHE PASSEPOILEES AVEC RABAT - POINT NOUE

AUTOMATA DE BOLSILLOS
AUTOMATA DE BOLSILLOS CON CANILLA GRANDE

パーツブック

PARTS BOOK

TEILEKATALOG

LIVRE DES PIECES

LIBRO DE REFERENCIA DE PIEZAS



パーツブックご利用に際して

1. 組単位で補給する部品は、 破線で示しております。
2. この本は1993年2月のデータに基づいて作成されたものです。
3. 部品は予告なしに設計変更される場合があります。
4. 部品コード欄・RMK 欄が*となっている場合は、ゲージ部品一覧表（86～89ページ）でお調べ下さい。

目 次

A. 主体関係	2	R2. 布制御関係	42
B. 上軸関係	2	R3. 布制御関係	46
C. 針棒揺動関係	4	R4. 布制御関係	50
D. 下軸関係	4	S. 針位置検出器関係	54
E. メス関係	6	T. ゲージ部品関係	54
F. カマ関係	8	U. 特別注文部品	56
G. 給油潤滑関係	10	V. 動力台関係	58
H. 糸通シ関係	14	W1. 特別注文部品	64
J. 糸切れ感知関係	16	W2. 特別注文部品（ダーツノバシ）	66
K1. スタッカー関係	18	W3. 特別注文部品（エアーイジェクター）	68
K2. スタッカー関係	22	W4. 特別注文部品（下送り装置）	68
L. 糸巻関係	26	X. 踏板関係（立ちペダル）	70
M. 糸切り関係	28	Z1. 付属品関係（自動機付属）	70
N. コントロールボックス関係	30	Z2. 付属品関係（頭部付属）	72
P. 空圧関係	32	索引	73～84
Q. 電装品関係	34	ゲージ部品一覧表	86～89
R1. 布制御関係	36		

Notes for using this parts book

1. Parts supplied as complete assemblies are circled by a dotted line (□□□□).
2. This book was prepared based on information available in February 1993.
3. Parts are subject to changes in design without prior notice.
4. If there is an asterisk in the parts code column, refer to the gauge parts list on page 86 ~ 89.

CONTENTS

A . Machine body	2	R2 . Cloth control system mechanism	42
B . Upper shaft mechanism	2	R3 . Cloth control system mechanism	46
C . Needle bar rocking mechanism	4	R4 . Cloth control system mechanism	50
D . Lower shaft mechanism	4	S . Synchronizer	54
E . Knife mechanism	6	T . Gauge mechanism	54
F . Rotary hook mechanism	8	U . Option parts	56
G . Lubrication	10	V . Power table	58
H . Threading mechanism	14	W1. Option parts	64
J . Thread breakage detector mechanism	16	W2. Option parts (Darts stretcher)	66
K1 . Stacker mechanism	18	W3. Option parts (Air ejector)	68
K2 . Stacker mechanism	22	W4. Option parts (Bottom feed set)	68
L . Bobbin winder mechanism	26	X . Foot switch pedal mechanism (Stand pedal)	70
M . Thread trimmer mechanism	28	Z1 . Accessories (provided with automatic sewing machine)	70
N . Control box mechanism	30	Z2 . Accessories (provided with machine body)	72
P . Air pressure mechanism	32	INDEX	73 ~ 84
Q . Power supply equipment mechanism	34	GAUGE PARTS LIST	86 ~ 89
R1 . Cloth control system mechanism	36		

Hinweise zur Verwendung dieser Teileliste

1. Die Teile, die als kompletter Satz geliefert werden, sind mit einer  gestrichelten Linie umrandet.
2. Dieses Buch basiert auf den Informationen vom Februar 1993.
3. Modelländerungen sind vorbehalten.
4. Falls in der Kolonne Teilecode ein Asteriskus vorhanden ist, wird auf die Lehrenteile auf Seite 86 ~ 89.

INHALTSVERZEICHNIS

A . Maschinengehäuse	2	R2 . Stoffführungsvorrichtung	42
B . Obere welle	2	R3 . Stoffführungsvorrichtung	46
C . Nadelstangenbetätigung	4	R4 . Stoffführungsvorrichtung	50
D . Untere welle	4	S . Synchronisator	54
E . Messer	6	T . Lehenvorrichtung	54
F . Greifervorrichtung	8	U . Sonderzubehör	56
G . Schmierung	10	V . Motorgestell	58
H . Fadenführungsvorrichtung	14	W1. Sonderzubehör	64
J . Fadenbruchfühler	16	W2. Sonderzubehör (Abnäherstrecker)	66
K1 . Anhäufung	18	W3. Sonderzubehör (Luftausstosser)	68
K2 . Anhäufung	22	W4. Sonderzubehör (Untertransportsatz)	68
L . Spuler	26	X . Fußbetätigung (Standpedal)	70
M . Fadenabschneidevorrichtung	28	Z1 . Zubehör (mit automatischer Nähmaschine)	70
N . Schaltkasten	30	Z2 . Zubehör (mit Nähmaschine)	72
P . Luftdruck	32	VERZEICHNIS	73 ~ 84
Q . Stromversorgung	34	LEHRENLISTE	86 ~ 89
R1 . Stoffführungsvorrichtung	36		

Notes sur l'utilisation de ce manuel de pièces détachées

1. Les pièces fournies en tant qu'assemblages complets sont encadrées avec un trait pointillé .
2. Ce manuel a été fait d'après les renseignements valables au mois de Février 1993.
3. Les pièces peuvent être sujettes à des modifications sans préavis.
4. S'il y a un astérisque dans la colonne de code des pièces, se reporter à la liste des pièces calibrées page 86 ~ 89.

TABLE DES MATIERES

A . Corps de la machine 2	R2 . Mécanisme de la système de contrôle du tissu 42
B . Mécanisme de l'arbre superieur 2	R3 . Mécanisme de la système de contrôle du tissu 46
C . Mécanisme de balancement de la barre à aiguille 4	R4 . Mécanisme de la système de contrôle du tissu 50
D . Mécanisme de l'arbre inférieur 4	S . Synchronisateur 54
E . Mécanisme du couteau 6	T . Mécanisme de jauge 54
F . Mécanisme du crocher rotatif 8	U . Pièces en option 56
G . Lubrification 10	V . Mécanisme du plateau de la machine 58
H . Mécanisme de l'enfilage 14	W1. Pièces en option 64
J . Mécanisme du détecteur de cassure du fil 16	W2. Pièces en option (tendeur pour pince) 66
K1 . Mécanisme de l'emplieur 18	W3. Pièces en option (éjecteur d'air) 68
K2 . Mécanisme de l'emplieur 22	W4. Pièces en option (Jeu d'entraînement inférieur) 68
L . Mécanisme du bobineur 26	X . Mécanisme de la pédale (Pédale à support) 70
M . Mécanisme de coupe-fill 28	Z1 . Accessoires (avec la machine à coudre automatique) 70
N . Mécanisme du boîtier de contrôle 30	Z2 . Accessoires (avec le corps de la machine) 72
P . Mécanisme de la pression d'air 32	INDEX 73 ~ 84
Q . Mécanisme de l'équipement en alimentation électrique 34	LISTE DES PIECES D'ECARTEMENT .. 86 ~ 89
R1 . Mécanisme de la système de contrôle du tissu 36	

Notas para usar este Manual de Piezas

1. Las piezas suministradas como conjuntos completos se enmarcan con una línea punteada (-----).
2. Este libro ha sido compilado basándose en los datos de que se disponía en febrero 1993.
3. Las piezas quedan sujetas a cambios de diseño sin aviso previo.
4. Para los asteriscos en la columna de código de piezas, consultar la lista de piezas de galga de la página 86 ~ 89.

INDICE

A . Cuerpo de la máquina 2	R2 . Mecanismo de la sistema de control de tela 42
B . Mecanismo del eje superior 2	R3 . Mecanismo de la sistema de control de tela 46
C . Mecanismo de oscilación de la barra de aguja 4	R4 . Mecanismo de la sistema de control de tela 50
D . Mecanismo del eje inferior 4	S . Sincronizador 54
E . Mecanismo del cuchilla 6	T . Mecanismo del galga 54
F . Mecanismo del cangrejo 8	U . Piezas opcionales 56
G . Lubricación 10	V . Mecanismo de la mesa de la máquina 58
H . Mecanismo del enhebrado 14	W1. Piezas opcionales 64
J . Mecanismo del sensor de cortes de hilo 16	W2. Piezas opcionales (estirador de sisa) 68
K1 . Mecanismo de apilador 18	W3. Piezas opcionales (eyector de aire) 68
K2 . Mecanismo de apilador 22	W4. Piezas opcionales (Juego de alimentación inferior) 68
L . Mecanismo del devanador de la canilla 26	X . Mecanismo del pedal (Pedal de soporte) .. 70
M . Mecanismo de la cortadura de hilos 28	Z1 . Accesorios (que vienen con la máquina de coser automática) 70
N . Mecanismo de la caja de controles 30	Z2 . Accesorios (con el cuerpo de la máquina) 72
P . Mecanismo de la presión de aire 32	INDICE 73 ~ 84
Q . Mecanismo del equipo de alimentación de corriente 34	LISTA DE PIEZAS CALIBRADORAS ... 86 ~ 89
R1 . Mecanismo de la sistema de control de tela 36	

A. 主体関係 / Machine body / Maschinengehäuse /
 Corps de la machine / Cuerpo de la máquina

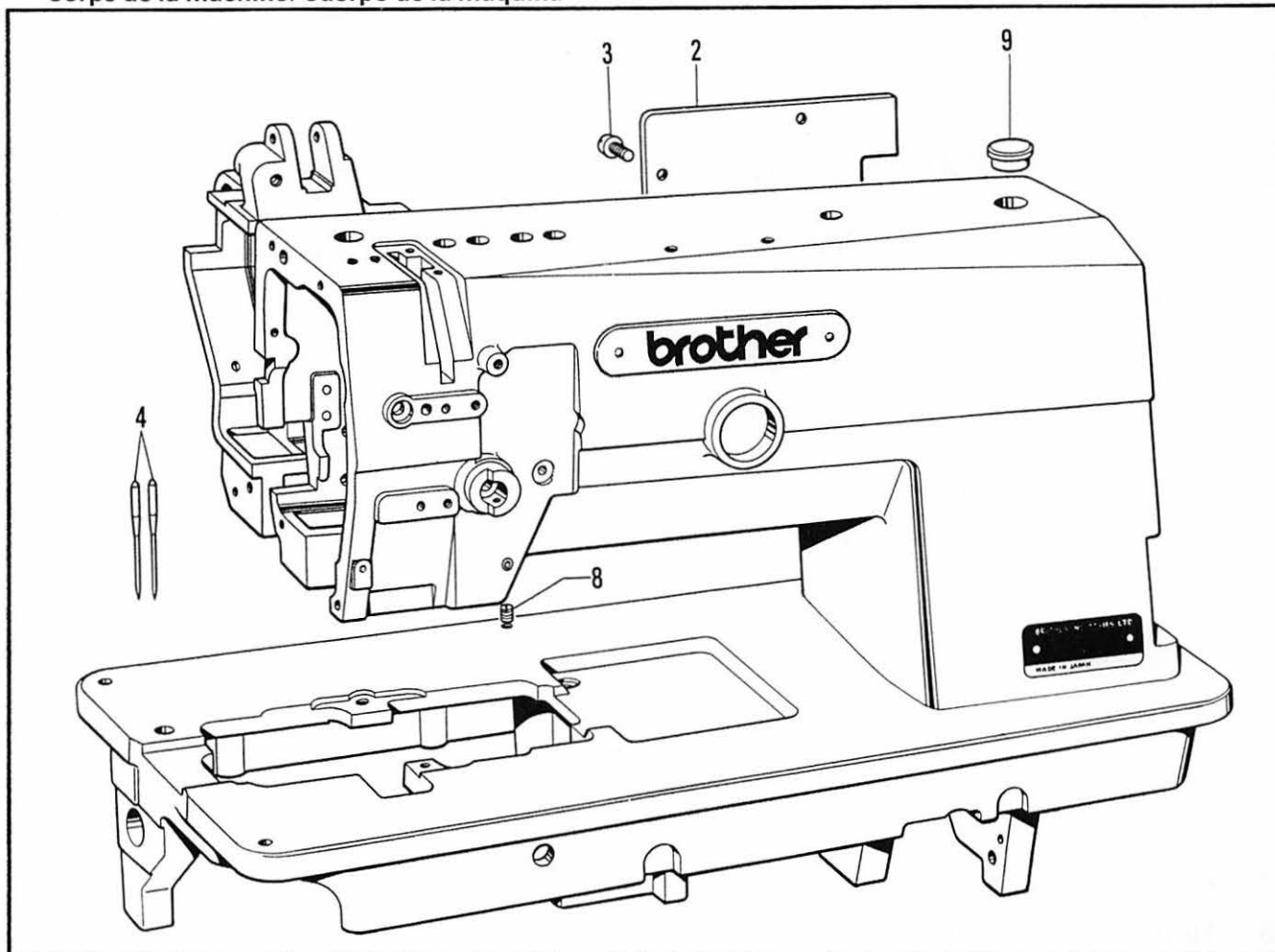

B. 上軸関係 / Upper shaft mechanism / Obere welle /
 Mécanisme de l'arbre supérieur / Mecanismo de la eje superior

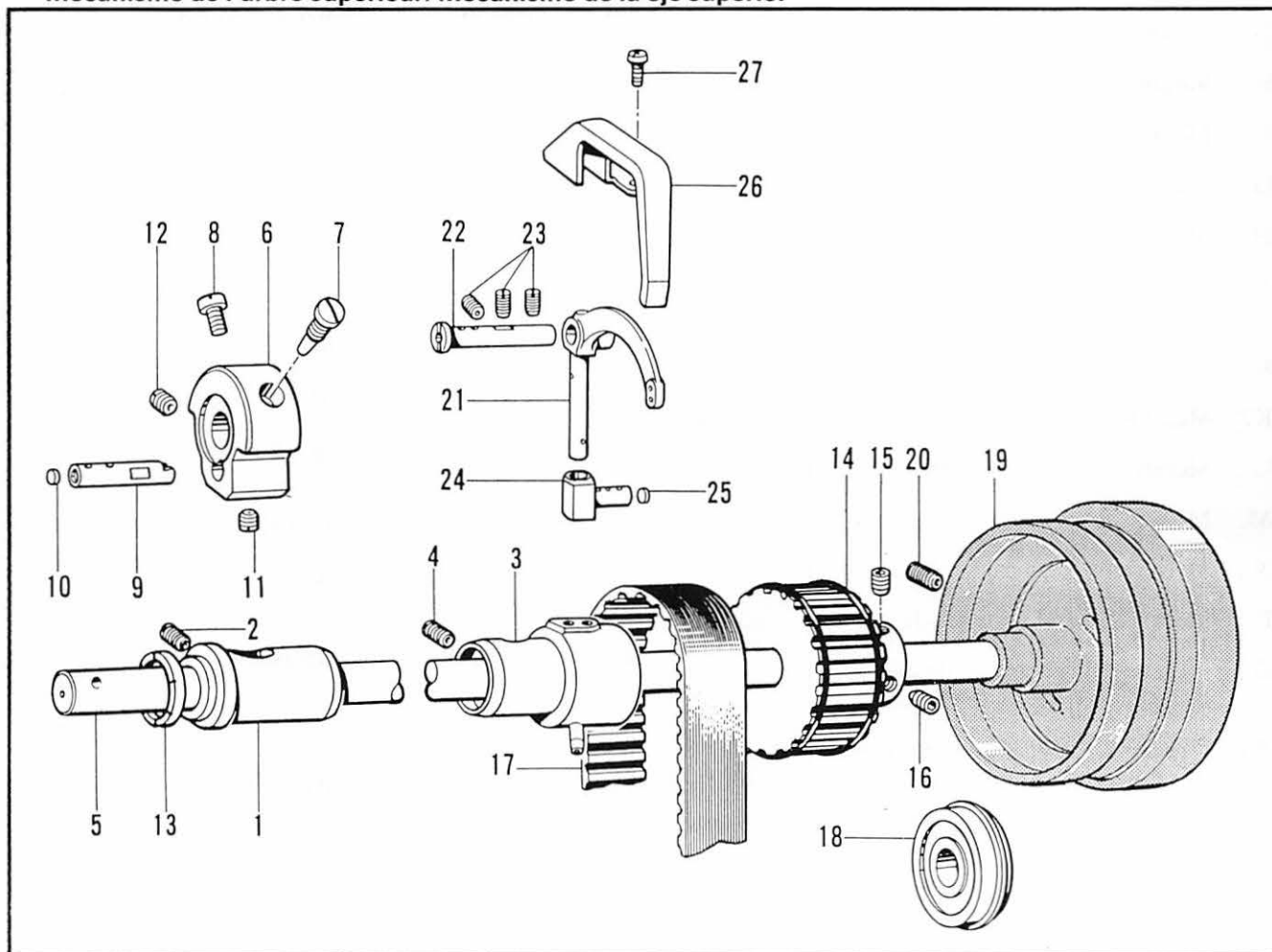

A. 主体関係/Machine body/Maschinengehäuse/
Corps de la machine/Cuerpo de la máquina

REF.NO.	CODE	Q'TY	ヒンメイ	NAME OF PARTS	RMKS
2	S14640009	1	カ ^ワ イタ	REAR COVER	
3	062680812	6	ナ ^ヘ コ437-40X8	SCREW 4.37X8	
4	153011016	2	ミシンハリMTX190 #16	NEEDLE MTX190 (#16)	
8	013719412	2	トメネジ ^{4.76} クホ ^ミ	SET SCREW 4.76	
9	159150009	1	カマジ ^ク メクラセン	OIL CAP	
			<オプションパーツ>	<OPTION PARTS>	
4	153011018	2	ミシンハリMTX190 #18	NEEDLE MTX190 (#18)	
4	153011011	2	ミシンハリMTX190 #11	NEEDLE MTX190 (#11)	

B. 上軸関係/Upper shaft mechanism/Obere welle/
Mécanisme de l'arbre supérieur/Mecanismo de la eje superior

REF.NO.	CODE	Q'TY	ヒンメイ	NAME OF PARTS	RMKS
1	112573101	1	ウワシ ^ク メタルL	UPPER SHAFT BUSH (L)	
2	013781012	1	トメネジ ^{6.35} クホ ^ミ	SET SCREW 6.35	
3	S07330101	1	ウワシ ^ク メタルMクミ	UPPER SHAFT BUSH (M) ASSY	
4	014780622	1	アナトメネジ ^{6.35} クホ ^ミ	SET SCREW 6.35	
5	S14668001	1	ウワシ ^ク	UPPER SHAFT	
6	112574000	1	デンビ ^ン クランク	THREAD TAKE-UP CRANK	
7	100250001	1	シメネジ ^{7.14}	SCREW 7.14	
8	146141001	1	アタマツキトメネジ ^{7.14}	SET SCREW 7.14	
9	112577101	1	ハリホ ^ウ クランク	NEEDLE BAR CRANK	
10	113014000	1	クミヒモフタ	PUSHER	
11	101706001	1	トメネジ ^{6.35}	SET SCREW 6.35	
12	100251001	1	トメネジ ^{6.35}	SET SCREW 6.35	
13	112576001	1	デンビ ^ン クランクリング	THREAD TAKE-UP CRANK RING	
14	180157001	1	タイミング ^プ ーリUクミ	TIMING PULLEY (U) ASSY	
15	014771022	1	アナトメネジ ^{6.35} クホ ^ミ	SET SCREW 6.35	
16	016771032	1	アナトガ ^リ 635X10	SET SCREW 635X10	
17	112586001	1	タイミング ^ハ ルト	TIMING BELT	
18	158115001	1	タマジ ^ク ウケ6204ZZNR	BALL BEARING 6204ZZNR	
19	S07340009	1	プーリ	PULLEY	
20	S09670001	2	トメクホ ^ミ 595-28X14	SET SCREW 595X14	
21	S09252001	1	デンビ ^ン	THREAD TAKE-UP	
22	S07334001	1	デンビ ^ン シ ^ク	THREAD TAKE-UP SHAFT	
23	013781012	3	トメネジ ^{6.35} クホ ^ミ	SET SCREW 6.35	
24	S07338001	1	デンビ ^ン ス ^ハ リコ	THREAD TAKE-UP SLIDE BLOCK	
25	113024000	1	クミヒモフタ	PUSHER	
26	S07339009	1	デンビ ^ン カ ^ハ ー	THREAD TAKE-UP COVER	
27	062670512	2	ナ ^ヘ コ357-40X5	SCREW 3.57X5	

C. 針棒搖動關係/Needle bar rocking mechanism/Nadelstangenbetätigung/
 Mécanisme de balancement de la barre à aiguille/Mecanismo de oscilación de la barra de aguja

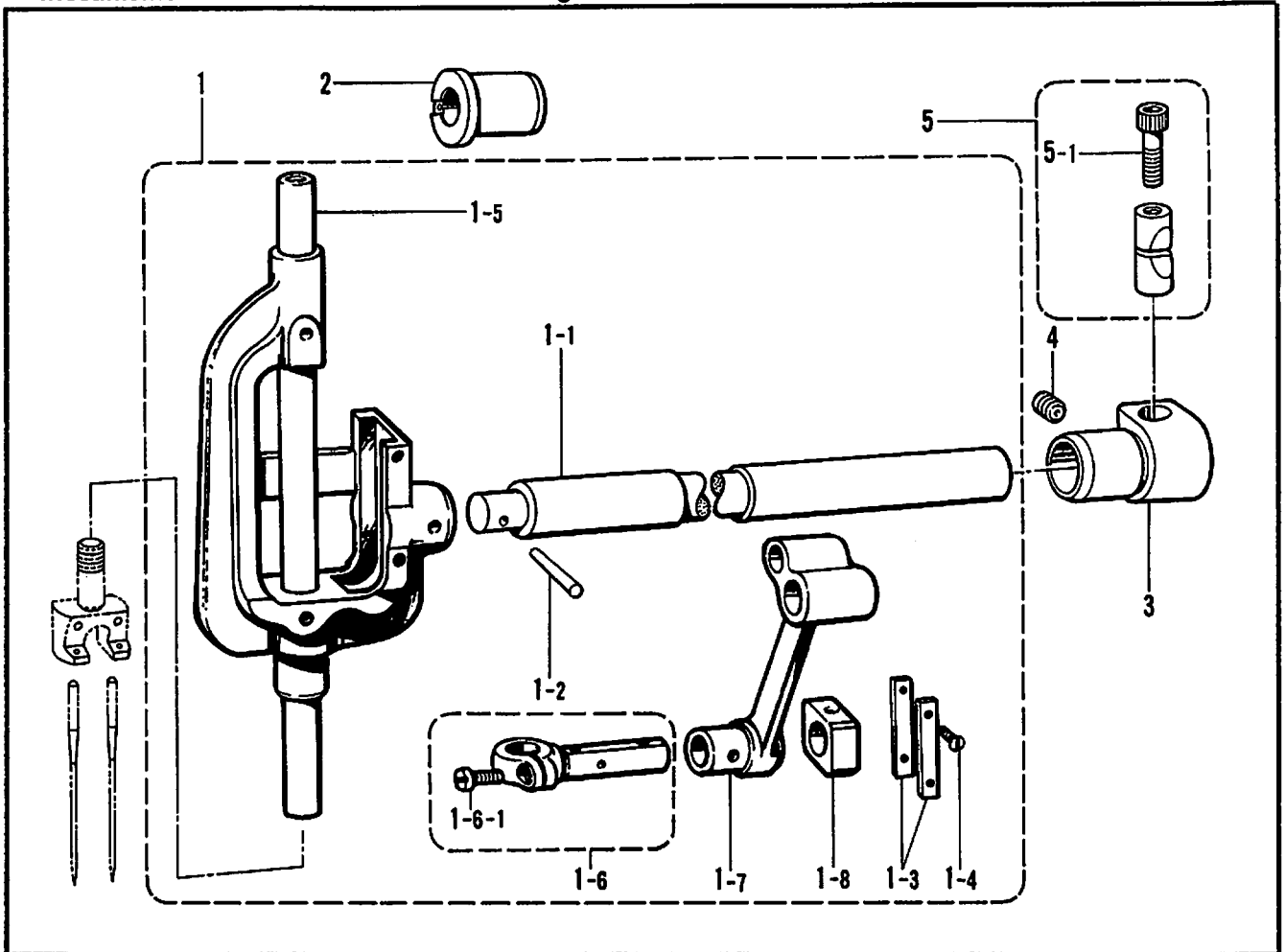

D. 下軸關係/Lower shaft mechanism/Untere welle/
 Mécanisme de l'arbre inférieur/Mecanismo del eje inferior

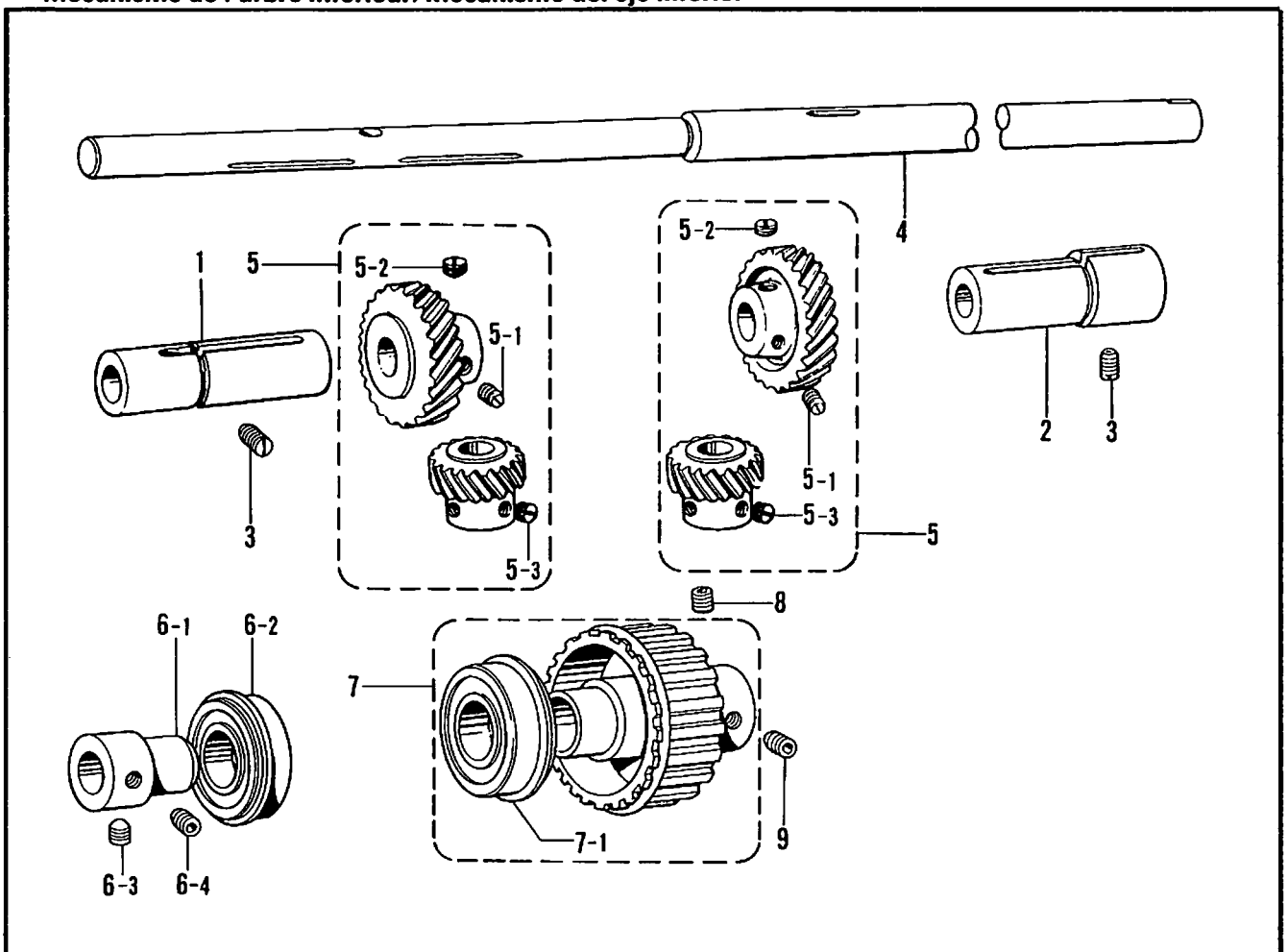

C. 針棒揺動関係/Needle bar rocking mechanism/Nadelstangenbetätigung/
 Mécanisme de balancement de la barre à aiguille/Mecanismo de oscilación de la barra de aguja

REF.NO.	CODE	Q'TY	ヒンメイ	NAME OF PARTS	RMKS
1	S15580001	1	ハリホ"ウヨウト"ウジ"ククミ	NEEDLE BAR ROCK SHAFT ASSY	
1-1	112588101	1	ハリホ"ウヨウト"ウジ"ク	NEEDLE BAR ROCK SHAFT	
1-2	S30570001	1	テーハ"ピン4X25	TAPER PIN 4X25	
1-3	112590001	2	ハリホ"ウアンナイイタ	GUIDE PLATE	
1-4	102731004	4	サラネジ"2.38	SCREW 2.38	
1-5	153009001	1	ハリホ"ウ	NEEDLE BAR	
1-6	S29863001	1	ハリホ"ウタ"キネジ"ツキ	NEEDLE BAR CLAMP WITH SCREW	
1-6-1	062670812	1	ナヘ"ゴ3.57-40X8	SCREW 3.57X8	
1-7	112593001	1	ハリホ"ウ克蘭クロット"	NEEDLE BAR CRANK ROD	
1-8	112721001	1	ハリホ"ウレンカンカクコマ	SLIDE BLOCK	
2	112594001	1	ヨウト"ウシ"クメタルL	NEEDLE BAR ROCK SHAFT BUSH (L)	
3	153012101	1	ヨウト"ウシ"クストツハ"	STOPPER	
4	013780710	1	トメネジ"6.35クホ"ミ	SET SCREW 6.35	
5	S09132001	1	ピンチスリーブ"クミ	PINCH SLEEVE ASSY	
5-1	018063022	1	アナホ"ルト6X30	BOLT 6X30	

D. 下軸関係/Lower shaft mechanism/Untere welle/
 Mécanisme de l'arbre inférieur/Mecanismo del eje inferior

REF.NO.	CODE	Q'TY	ヒンメイ	NAME OF PARTS	RMKS
1	S09287000	1	カマト"タ"イメタルL	ROTARY HOOK BASE BUSH (L)	
2	S09288000	1	カマト"タ"イメタルR	ROTARY HOOK BASE BUSH (R)	
3	014780622	2	アナトメネジ"6.35クホ"ミ	SET SCREW 6.35	
4	S07439001	1	シタジ"ク	LOWER SHAFT	
5	S12445001	2	スパ"イラルキ"ヤクミA	SPIRAL GEAR ASSY (A)	
5-1	112684001	2	トメネジ"6.35	SET SCREW 6.35	
5-2	100251001	4	トメネジ"6.35	SET SCREW 6.35	
5-3	131007001	6	トメネジ"6.35クホ"ミ	SET SCREW 6.35	
6	S07446001	1	タマジ"クウケクミ	BALL BEARING ASSY	
6-1	S07447001	1	タマジ"クウケフ"ツシユ	BALL BEARING BUSH	
6-2	072600480	1	タマジ"クウケ6004ZZNR	BALL BEARING 6004ZZNR	
6-3	148821001	1	アナトメネジ"6.35トガ"リ	SET SCREW 6.35	
6-4	014771022	1	アナトメネジ"6.35クホ"ミ	SET SCREW 6.35	
7	S07442001	1	タイミング"プ"ーリDクミ	TIMING PULLEY (D) ASSY	
7-1	158115001	1	タマジ"クウケ6204ZZNR	BALL BEARING 6204ZZNR	
8	014771022	1	アナトメネジ"6.35クホ"ミ	SET SCREW 6.35	
9	148821001	1	アナトメネジ"6.35トガ"リ	SET SCREW 6.35	

E. メス関係/Knife mechanism/Messer/
Mécanisme du couteau/Mecanismo del cuchilla

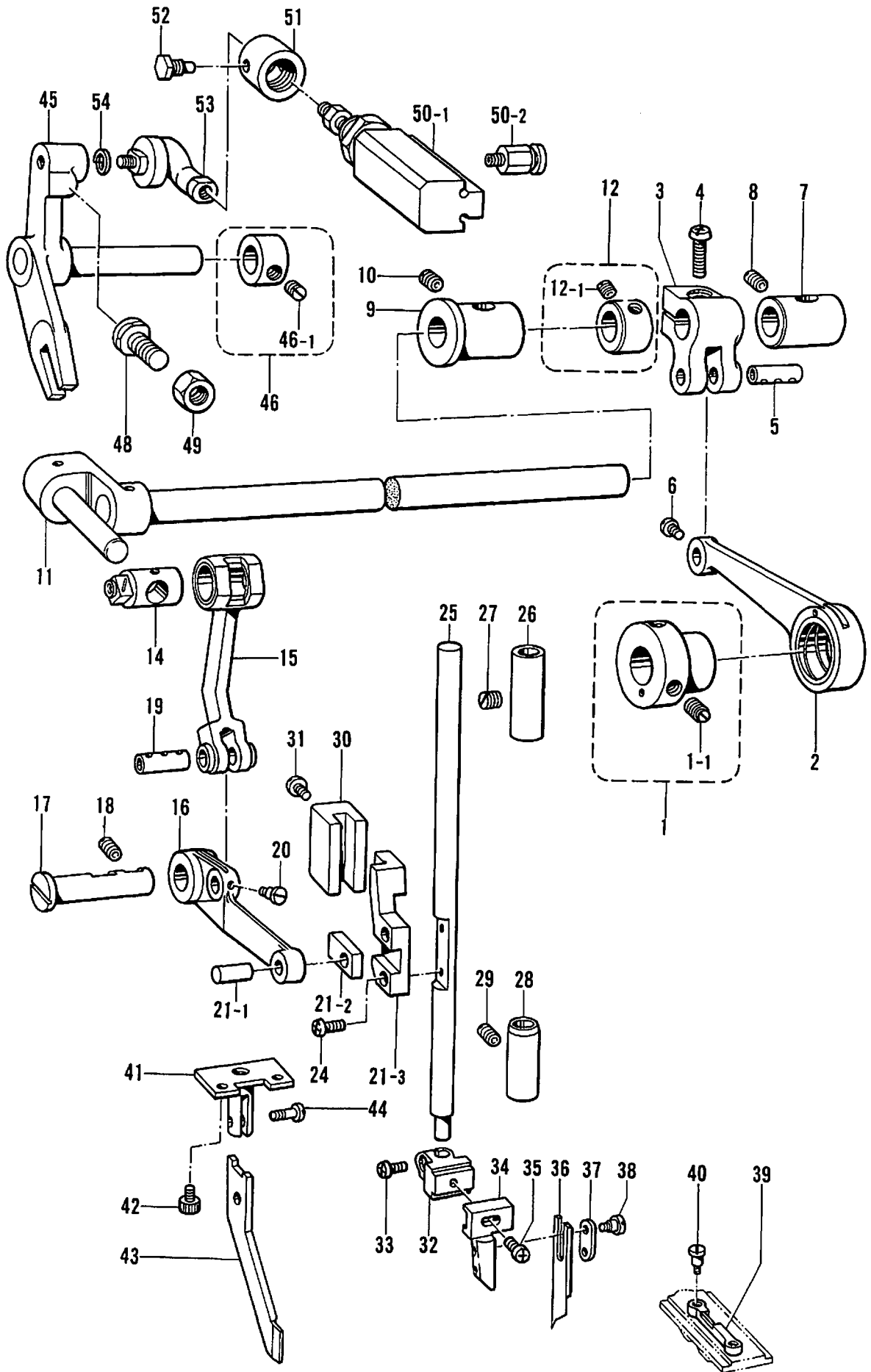

E. メス関係/Knife mechanism/Messer/
Mécanisme du couteau/Mecanismo del cuchilla

REF.NO.	CODE	Q'TY	ヒンメイ	NAME OF PARTS	RMKS
1	153015001	1	クト"ウヘンシンリンネジ"ツキ	ECCENTRIC WHEEL WITH SCREW	
1-1	151604001	2	トメネジ"5.95	SET SCREW 5.95	
2	S14642001	1	クト"ウジ"クレンカン	CRANK SHAFT CONNECTING ROD	
3	S14674001	1	クト"ウジ"クウテ"	CRANK SHAFT ARM	
4	062751612	1	ナヘ"コ556-32X16	SCREW 556X16	
5	143625001	1	ジ"ク6.35X17	STUD 6.35X17	
6	110563001	1	シメネジ"3.18	SCREW 3.18	
7	143626000	1	クト"ウジ"クメタルR	UPPER KNIFE ROCK SHAFT BUSH (R)	
8	013781012	1	トメネジ"6.35クホ"ミ	SET SCREW 6.35	
9	143627000	1	クト"ウジ"クメタルL	UPPER KNIFE ROCK SHAFT BUSH (L)	
10	013781012	1	トメネジ"6.35クホ"ミ	SET SCREW 6.35	
11	S14643001	1	ヨウト"ウウテ"クミ	ROCK ARM ASSY	
12	183677001	1	セツトカラー"ネジ"ツキ	SET COLLAR WITH SCREW	
12-1	100260001	2	トメネジ"5.95	SET SCREW 5.95	
14	S14647001	1	サト"ウレンカンスヘ"リコクミ	DRIVING ROD SLIDE BLOCK ASSY	
15	S14649001	1	サト"ウレンカン	DRIVING CONNECTING ROD	
16	S14650001	1	サト"ウレハ"ー	DRIVING LEVER	
17	S14651001	1	サト"ウレハ"ー"ジ"ク	DRIVING LEVER SHAFT	
18	013781012	1	トメネジ"6.35クホ"ミ	SET SCREW 6.35	
19	143625001	1	ジ"ク6.35X17	STUD 6.35X17	
20	110563001	1	シメネジ"3.18	SCREW 3.18	
21	183699001	1	メスホ"ウアンナイ"クミ	KNIFE BAR GUIDE ASSY	
21-1	143637001	1	ジ"ク5.5X11	STUD 5.5X11	
21-2	143646000	1	メスホ"ウアンナイ"カクコマ	KNIFE BAR GUIDE BLOCK	
21-3	S14652001	1	メスホ"ウアンナイ	KNIFE BAR GUIDE	
24	062670812	2	ナヘ"コ3.57-40X8	SCREW 3.57X8	
25	S14653001	1	メスホ"ウ	KNIFE BAR	
26	S14654001	1	メスホ"ウメタルU	KNIFE BAR BUSH (U)	
27	013781012	1	トメネジ"6.35クホ"ミ	SET SCREW 6.35	
28	S14655001	1	メスホ"ウメタルD	KNIFE BAR BUSH (D)	
29	013781012	1	トメネジ"6.35クホ"ミ	SET SCREW 6.35	
30	S14656001	1	メスジ"クアンナイ	KNIFE SHAFT GUIDE	
31	062671012	2	ナヘ"コ357-40X10	SCREW 3.57X10	
32	S14657001	1	メスホルター"ー	KNIFE HOLDER	
33	062670712	1	ナヘ"コ357-40X7	SCREW 3.57X7	
34	S14658001	1	メストリツケホ"ウ	KNIFE SET BAR	
35	112751003	1	シメネジ"3.57	SCREW 3.57	
36	S16248101	1	ウワメスB	UPPER KNIFE (B)	
37	143641001	1	メスオサエイタ	UPPER KNIFE PRESSER PLATE	
38	143642101	2	メスオサエタ"ンネジ"	KNIFE PRESSER STUD SCREW	
39	153020001	1	コテイハ	FIXED KNIFE	
40	148539101	2	ダ"ンネジ"2.38	STUD SCREW 2.38	
41	S14659001	1	メスガ"イト"ホ"ウ	KNIFE GUIDE SHAFT	
42	S00208001	2	アナホ"ルト3.57X7	BOLT 3.57X7	
43	S14660101	1	ナカメスガ"イト"	INNER KNIFE GUIDE	
44	113050001	1	シメネジ"3.57	SCREW 3.57	
45	S14661009	1	キリカエレハ"ークミ	SELECTOR LEVER ASSY	
46	S10588001	1	セツトカラー"クミ	SET COLLAR ASSY	
46-1	100260001	2	トメネジ"5.95	SET SCREW 5.95	
48	115585001	1	ボ"ルト7.94	BOLT 7.94	
49	152997001	1	ナツト7.94	NUT 7.94	
50	S14665000	1	シリンダ"クミ	CYLINDER ASSY	
50-1	S14666000	1	シリンダ"16X20	CYLINDER 16X20	
50-2	S04905000	2	ハーフユニオン	HALF UNION	
51	S14667001	1	シリンダ"ダ"イ	CYLINDER BASE	
52	140620001	2	シリンダ"ササエネジ"	CYLINDER SUPPORT SCREW	
53	S08408000	1	リンクホ"ール	LINK BALL	
54	028050243	1	ハ"ネサ"ガ"ネ2-5	SPRING WASHER 2-5	

F. カマ関係 / Rotary hook mechanism / Greifervorrichtung /
 Mécanisme du crocher rotatif / Mecanismo del cangrejo

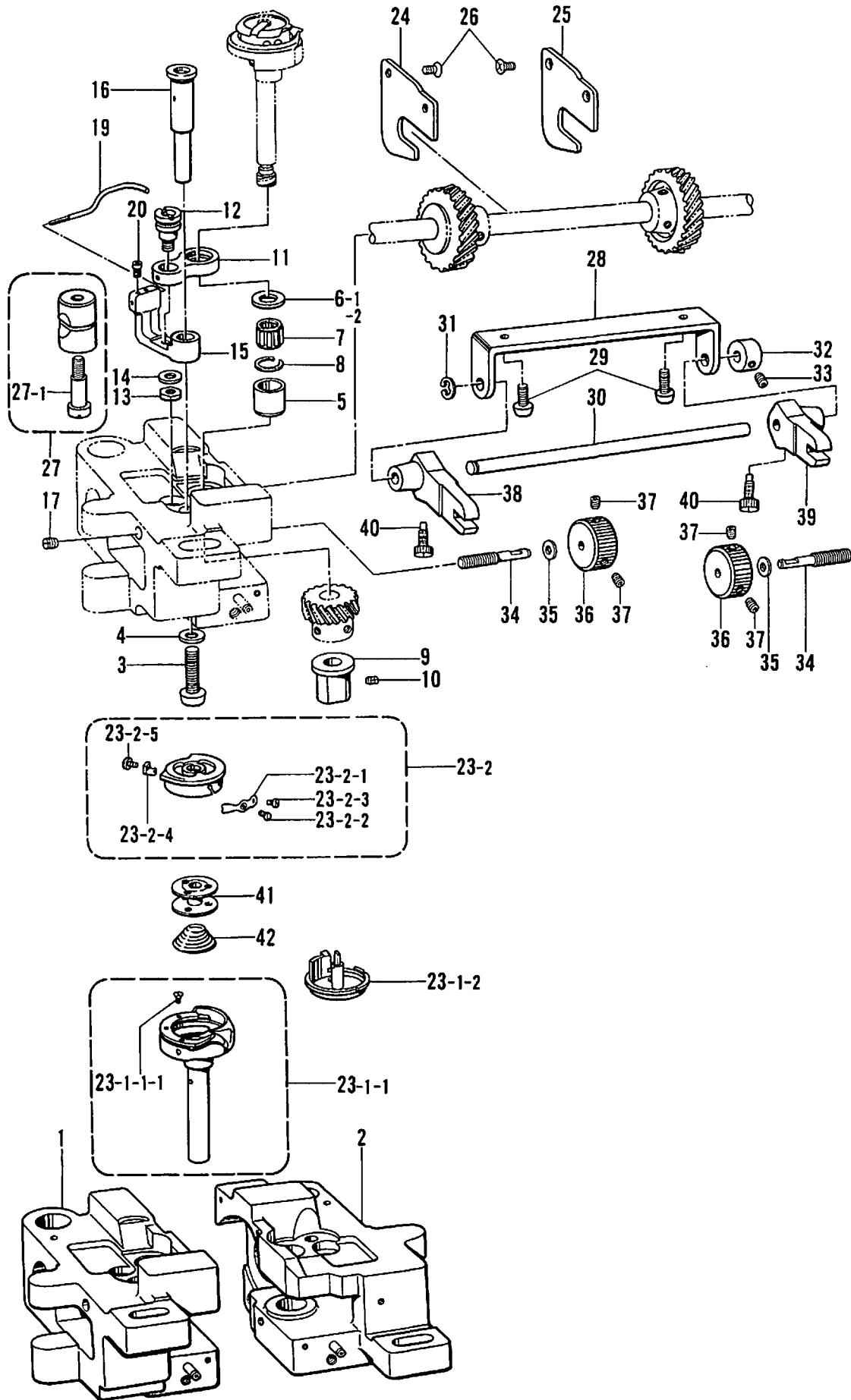

F. カマ関係/Rotary hook mechanism/Greifervorrichtung/
Mécanisme du crocher rotatif/Mecanismo del cangrejo

REF.NO.	CODE	Q'TY	ヒンメイ	NAME OF PARTS	RMKS
1	S09255201	1	カマト"タ"イL	ROTARY HOOK BASE (L)	
2	S15068101	1	カマト"タ"イR	ROTARY HOOK BASE (R)	
3	062782512	2	ナヘ"コ635-28X25	SCREW 635X25	
4	100197002	2	ザ"カ"ネ	WASHER	
5	S09259001	2	カマジ"クメタルU	ROTARY HOOK SHAFT BUSH (U)	
6-1	S09260001	2	スラストリング"A 1.2MM	THRUST RING (A) (1.2MM)	
6-2	S09261001	2	スラストリング"B 1.4MM	THRUST RING (B) (1.4MM)	
7	S07420000	2	ニードル"ル"へ"アリング"	NEEDLE BEARING	
8	S07419001	2	ストップリング"	STOP RING	
9	S07417001	2	カマジ"クメタルD	ROTARY HOOK SHAFT BUSH (D)	
10	013710512	2	トメネジ"4.76クホ"ミ	SET SCREW 4.76	
11	150967101	2	オープナーリンク	OPENER LINK	
12	148005001	2	オープナーリンクシャフト	OPENER LINK SHAFT	
13	110161006	2	ナット4.76	NUT 4.76	
14	025710232	2	ヒラサ"ガ"ネチユウ4.76	PLAIN WASHER 4.76	
15	S09262101	2	オープナーレバー	OPENER LEVER	
16	S13021001	2	オープナーレバーシャフト	OPENER LEVER SHAFT	
17	013711012	2	トメネジ"4.76クホ"ミ	SET SCREW 4.76	
19	S07423101	2	オープナー	OPENER	
20	S07424001	4	トメネジ"3.18	SET SCREW 3.18	
23	S09264001	2	ニホンハリカマ	TWIN NEEDLE ROTARY HOOK ASSY	
23-1	S13615001	2	カマクミ	ROTARY HOOK ASSY	
23-1-1	S09268001	2	ソトカマクミ	OUTER ROTARY HOOK ASSY	
23-1-1-1	151027001	4	ウチカマオサエトメネジ"	INNER ROTARY HOOK SET SCREW	
23-1-2	S09273001	2	ウチカマクミ	INNER ROTARY HOOK ASSY	
23-2	S09278001	2	キャップクミ	CAP ASSY	
23-2-1	155479001	2	チヨウシハ"ネ	TENSION SPRING	
23-2-2	151029001	2	チヨウシネジ"	TENSION ADJUST SCREW	
23-2-3	151030001	2	チヨウシハ"ネトメネジ"	SET SCREW	
23-2-4	S09284001	2	シタイトホジ"イタ	LOWER THREAD HOLDING PLATE	
23-2-5	159802001	2	シメネジ"1.59X2	SCREW 1.59X2	
24	S07436001	1	キ"ヤアンナイL	GEAR GUIDE (L)	
25	S07437001	1	キ"ヤアンナイR	GEAR GUIDE (R)	
26	108960002	4	サラネジ"3.57	SCREW 3.57	
27	S07658001	2	ピンチスリーブ"クミ	PINCH SLEEVE ASSY	
27-1	112700001	2	シメネジ"5.95	SCREW 5.95	
28	S07430001	1	ハリスキチヨウセツホ"ウササエ	ADJUST BAR SUPPORT	
29	062711012	2	ナヘ"コ476-32X10	SCREW 4.76X10	
30	S07431001	1	ハリスキチヨウセツホ"ウ	ADJUST BAR	
31	048040342	1	トメフE4	STOP RING E4	
32	159436001	1	セツトカラー	SET COLLAR	
33	014680622	1	アナトメネジ"4.37クホ"ミ	SET SCREW 4.37	
34	S07434001	2	ハリスキチヨウセツネジ"	ADJUST SCREW	
35	025680132	2	ヒラサ"ガ"ネシヨウ4.37	PLAIN WASHER 4.37	
36	S07435001	2	ハリスキチヨウセツナット	ROTARY HOOK BASE ADJUST DIAL	
37	014680622	4	アナトメネジ"4.37クホ"ミ	SET SCREW 4.37	
38	S07432001	1	ハリスキチヨウセツフタマタL	ADJUST FORKED LEVER (L)	
39	S07433001	1	ハリスキチヨウセツフタマタR	ADJUST FORKED LEVER (R)	
40	131226001	2	ハリトメネジ"3.57	NEEDLE SET SCREW 3.57	
41	S09285001	4	ホ"ビ"ン	BOBBIN	
42	156557001	2	クウデンホ"ウシハ"ネ	BOBBIN TENSION SPRING	

G. 給油潤滑關係 / Lubrication / Schmierung /
Lubrification / Lubricación

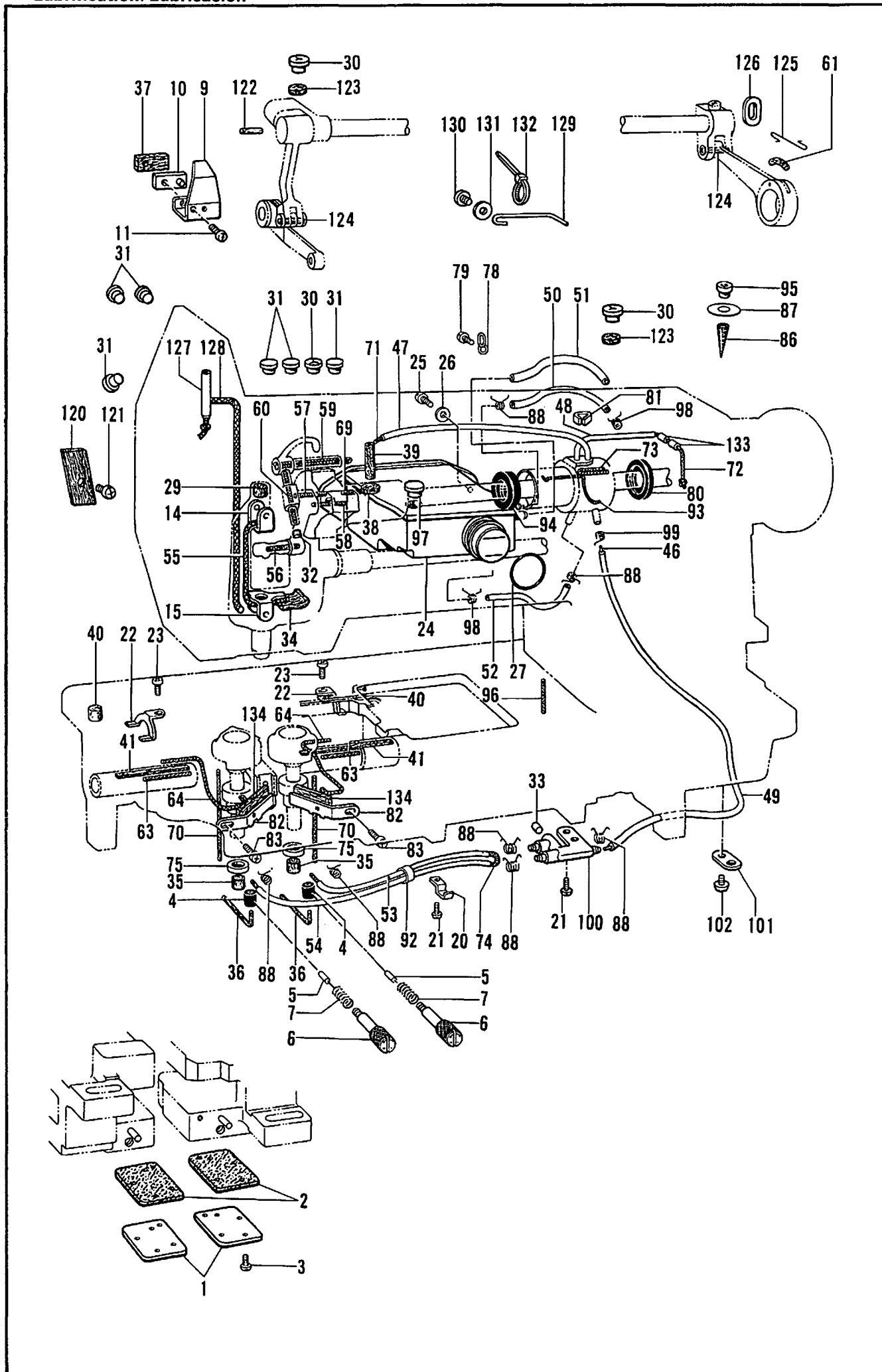

G. 給油潤滑関係 / Lubrication / Schmierung /
Lubrification / Lubricación

REF.NO.	CODE	QTY	ヒンメイ	NAME OF PARTS	RMKS
1	S07448001	2	カマト"タ"イフタ	ROTARY HOOK BASE COVER	
2	S07449000	2	カマト"タ"イハ"ツキン	ROTARY HOOK BASE PACKING	
3	062670812	8	ナヘ"ユ3.57-40X8	SCREW 3.57X8	
4	S07477000	2	ゴムリング"	RUBBER RING	
5	S07478000	2	ゴムオサエ	RUBBER PRESSER	
6	S07479101	2	オイルチヨウセツネジ"	ADJUST SCREW	
7	S16114001	2	オイルチヨウセツハ"ネ	SPRING	
9	150988001	1	オイルヨケイタ	OIL STOPPER PLATE	
10	112717001	1	オイルヨケイタオサエカネ	OIL STOPPER PLATE PRESSER	
11	062711212	1	ナヘ"ユ4.76-32X12	SCREW 4.76X12	
14	112719001	1	フェルトオサエU	FELT SUPPORT (U)	
15	112720101	1	フェルトオサエD	FELT SUPPORT (D)	
20	142268001	1	コード"オサエL	CORD HOLDER (L)	
21	062670512	3	ナヘ"ユ3.57-40X5	SCREW 3.57X5	
22	S07471001	2	ヒモササエ	WICK HOLDER	
23	062670512	2	ナヘ"ユ3.57-40X5	SCREW 3.57X5	
24	S07450109	1	オイルタンククミ	OIL TANK ASSY	
25	062711012	2	ナヘ"ユ4.76-32X10	SCREW 4.76X10	
26	025710232	2	ヒラサ"ガ"ネチユウ4.76	PLAIN WASHER 4.76	
27	081030070	1	Oリング" P30	O RING P30	
29	148394000	1	ハリホ"ウセン	NEEDLE BAR CAP	
30	140890009	3	オイルカツプ"	OIL CAP	
31	104821009	6	メクラセン	OIL CAP	
32	142274009	1	メクラセン	OIL CAP	
33	142274009	1	メクラセン	OIL CAP	
34	S07474000	1	フェルト	FELT	
35	151927001	2	クラツチフェルト	CLUTCH FELT	
36	S07476000	2	フェルト	FELT	
37	148762001	1	デンヒ"ンフェルト	FELT	
38	112734001	1	ウツジ"クメタルLフェルト	UPPER SHAFT BUSH (L) FELT	
39	S07571000	1	フェルト	FELT	
40	112753001	3	フェルト	FELT	
41	113362001	2	カマト"タ"イメタルRフェルト	ROTARY HOOK BASE BUSH (R) FELT	
46	S07460100	1	ワイヤー	WIRE	
47	S07453000	1	ヒ"ニールチューブ"	OIL TUBE (L=190)	
48	143669000	1	ヒ"ニールチューブ"	OIL TUBE (L=115)	
49	S07455100	1	ヒ"ニールチューブ"	OIL TUBE (L=390)	
50	S07456000	1	ヒ"ニールチューブ"	OIL TUBE (L=160)	
51	S07457100	1	ヒ"ニールチューブ"	OIL TUBE (L=160)	
52	S07810000	1	ヒ"ニールチューブ"	OIL TUBE (L=90)	
53	S07458100	1	ヒ"ニールチューブ"	OIL TUBE (L=180)	
54	S07459100	1	ヒ"ニールチューブ"	OIL TUBE (L=240)	
55	S07465000	1	クミヒモ (L=200)	WICK (L=200)	
56	112728001	1	クミヒモ (L=50)	WICK (L=50)	
57	114693001	1	クミヒモ (L=30)	WICK (L=30)	
58	112735000	1	クミヒモ (L=45)	WICK (L=45)	
59	113653000	1	クミヒモ (L=130)	WICK (L=130)	
60	S03289001	1	クミヒモ4X4 (L=40)	WICK 4X4 (L=40)	
61	112293001	1	ハリホ"ウリソクジ"クフェルト	FELT	
63	S07461000	2	クミヒモ (L=32)	WICK (L=32)	
64	108802001	2	クミヒモ4X4 (L=250)	WICK 4X4 (L=250)	
69	S07462000	1	クミヒモ (L=25)	WICK (L=25)	
70	S07463000	2	クミヒモ (L=70)	WICK (L=70)	
71	153920001	1	クミヒモ4X4 (L=300)	WICK 4X4 (L=300)	
72	S10167000	1	クミヒモ4X4 (L=200)	WICK 4X4 (L=200)	
73	S03289001	1	クミヒモ4X4 (L=40)	WICK 4X4 (L=40)	
74	S07464100	1	クミヒモ (L=530)	WICK (L=530)	
75	156070002	2	スペ"ーサー	SPACER	
78	S07467001	1	チューブ"ササエ	TUBE SUPPORT	
79	062680812	1	ナヘ"ユ4.37-40X8	SCREW 4.37X8	
80	S07468000	1	オイルシール	OIL SEAL	
81	S07469001	1	チューブ"カシメ	TUBE CALKING	

G. 給油潤滑關係 / Lubrication / Schmierung /
Lubrification / Lubricación

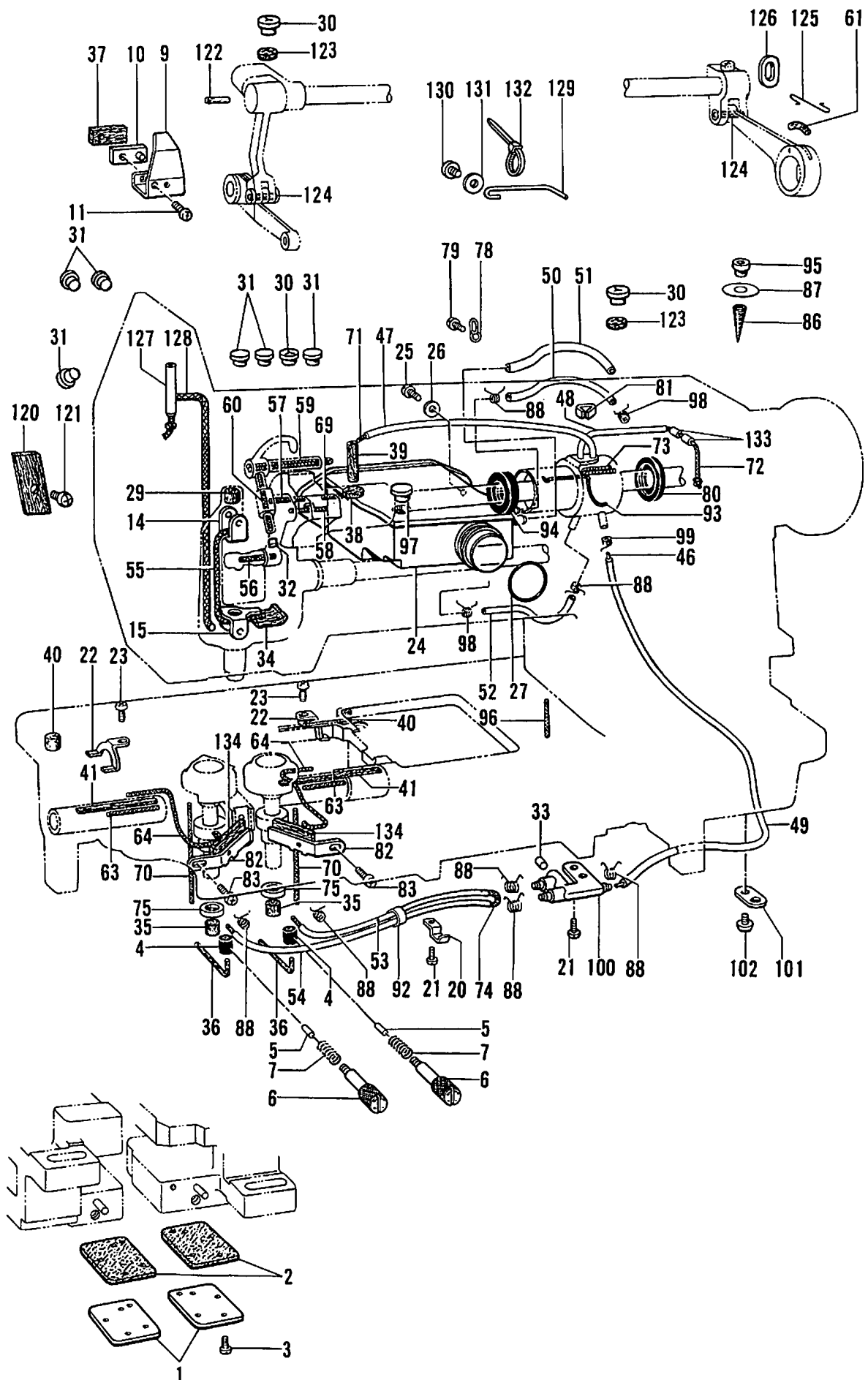

G. 給油潤滑関係 / Lubrication / Schmierung /
Lubrication / Lubricación

REF.NO.	CODE	Q'TY	ヒンメイ	NAME OF PARTS	RMKS
82	S21195001	2	フェルトオサエ	FELT SUPPORT	
83	062670512	2	ナヘ"コ357-40X5	SCREW 3.57X5	
86	S07473000	1	オイルフィルター	OIL FILTER	
87	S07481009	1	オイルシート	OIL MARK SEAT	
88	S07876001	7	チューブ"ストツハ°	TUBE CLAMP	
92	146253000	1	チューブ" (L=5)	OIL TUBE (L=5)	
93	S09369000	1	クミヒモ (L=70)	WICK (L=70)	
94	S09364000	1	オイルシール	OIL SEAL	
95	112758009	1	ハ"ツト"オイルフタ	OIL CAP	
96	111191001	1	クミヒモ (L=35)	WICK (L=35)	
97	104821009	1	メクラセン	OIL CAP	
98	S07876001	2	チューブ"ストツハ°	TUBE CLAMP	
99	S07876001	1	チューブ"ストツハ°	TUBE CLAMP	
100	S14189000	1	ターミナル	TERMINAL	
101	146536001	1	オクリホ"タンシ"クササエ	FEED ADJUST SHAFT SUPPORT	
102	062670512	1	ナヘ"コ357-40X5	SCREW 3.57X5	
120	143679000	1	フェルト	FELT	
121	060670612	1	ハ"イント"357-40X6	SCREW 357X6	
122	153024000	1	クミヒモ (L=25)	WICK (L=25)	
123	143936000	2	フェルト	FELT	
124	112293001	2	ハリホ"ウリンクシ"クフエルト	FELT	
125	116795000	1	クリツフ°	CLIP	
126	143676000	1	レンガンオイルキリ	OIL SEAL	
127	S14685001	1	パイプ°	PIPE	
128	152974001	1	クミヒモ4X4 (L=350)	WICK 4X4 (L=350)	
129	S18087001	1	チューブ"ササエ	TUBE SUPPORT	
130	062781412	1	ナヘ"コ635-28X14	SCREW 635X14	
131	151439002	1	サ"カ"ネ	WASHER	
132	149799000	1	タイラツフ°S	BEAD BAND (S)	
133	S18385000	2	ビ"ニルチューブ"(L=10)	OIL TUBE (L=10)	
134	S21196001	2	フェルト	FELT	

H. 糸通シ関係/Threading mechanism/Fadenführungsrichtung/
 Mécanisme de l'enfilage/Mecanismo de la enhebrado

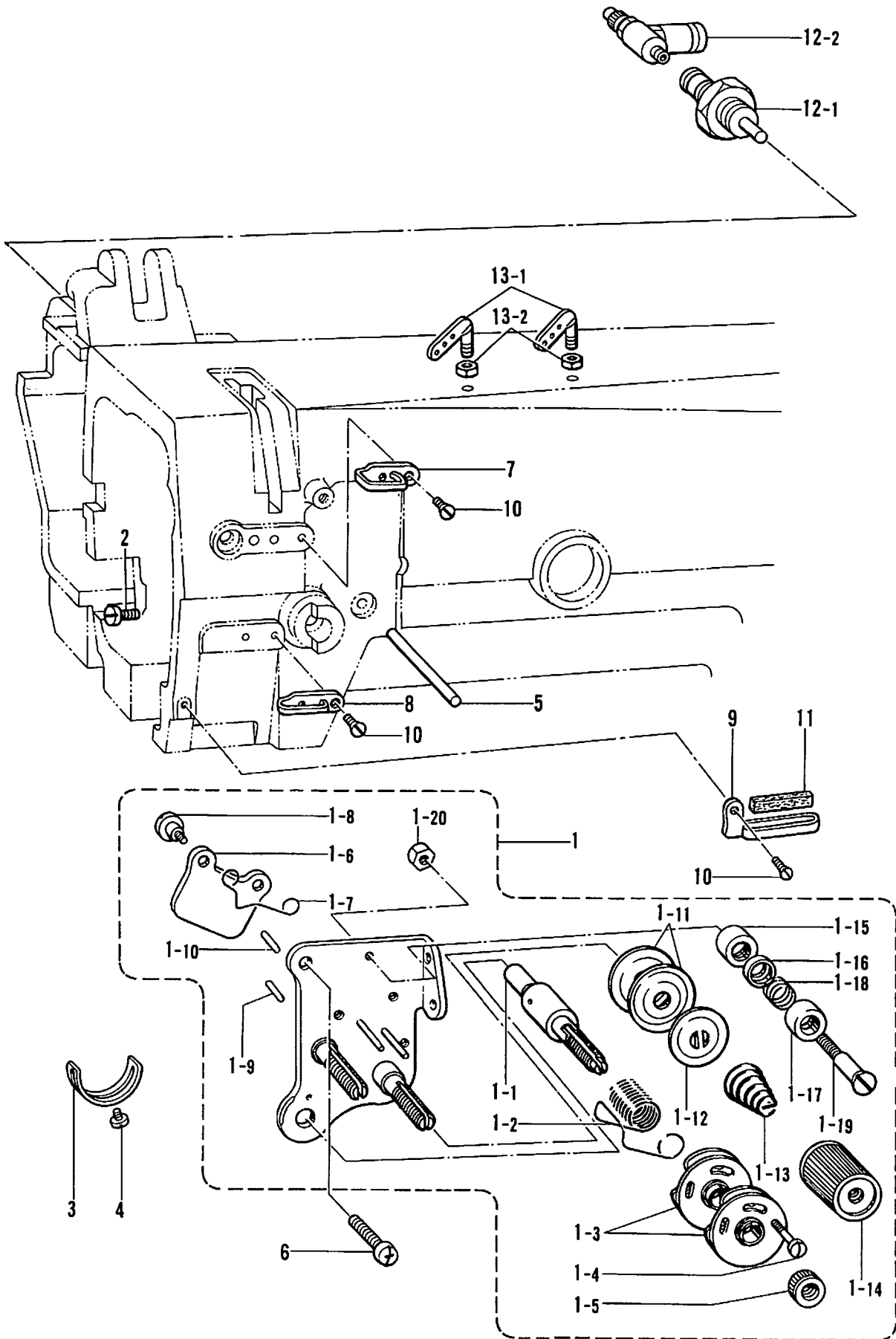

H. 糸通シ関係/Threading mechanism/FadenführungsVorrichtung/
Mécánisme de l'enfilage/Mecanismo de la enhebrado

REF.NO.	CODE	QTY	ヒンメイ	NAME OF PARTS	RMKS
1	S07489109	1	ウフイトチヨウシクミ	UPPER THREAD TENSION ASSY	
1-1	144680001	1	チヨウシシ"ク	TENSION STUD	
1-2	155491001	1	イトトリハ"ネ	SPRING	
1-3	108254001	2	イトトリハ"ネアンナイクミ	SPRING GUIDE ASSY	
1-4	144682001	1	シメネシ"2.38	SCREW 2.38	
1-5	108265009	1	イトチヨウシナツト	TENSION NUT	
1-6	S07487001	1	イトユルメイタ	TENSION RELEASE PLATE	
1-7	118320001	1	イトユルメハ"ネ	SPRING	
1-8	112712001	2	タ"ンネシ"3.57	STUD SCREW 3.57	
1-9	158769001	1	イトユルメピンR	PIN (R)	
1-10	S07488001	1	イトユルメピンL	PIN (L)	
1-11	145446001	4	イトチヨウシサラ	TENSION DISC	
1-12	159805001	2	イトチヨウシサラオサエ	TENSION DISC PRESSER	
1-13	S07490001	2	イトチヨウシハ"ネ	TENSION SPRING	
1-14	149566009	2	イトチヨウシナツト	TENSION NUT	
1-15	144685001	2	イトアンナイフタ	THREAD GUIDE CAP	
1-16	144686001	2	イトアンナイサラ	THREAD GUIDE DISC	
1-17	144687001	2	イトアンナイダ"イ	THREAD GUIDE BRACKET	
1-18	144688001	2	イトアンナイハ"ネ	SPRING	
1-19	144689001	2	イトアンナイダ"ンネシ"	THREAD GUIDE STUD SCREW	
1-20	021670102	2	ナツト1 シユ3.57	NUT 3.57	
2	100064002	1	シメネシ"3.57	SCREW 3.57	
3	112709001	1	イトトリハ"ネストツハ"	STOPPER	
4	062670512	1	ナハ"ユ357-40X5	SCREW 3.57X5	
5	S14677001	1	イトユルメシ"ク	TENSION RELEASE SHAFT	
6	062680812	1	ナハ"ユ437-40X8	SCREW 4.37X8	
7	108266001	1	ア-ムイトアンナイU	ARM THREAD GUIDE (U)	
8	112658001	1	ア-ムイトアンナイM	ARM THREAD GUIDE (M)	
9	112715001	1	ア-ムイトアンナイD	ARM THREAD GUIDE (D)	
10	108960002	3	サラネシ"3.57	SCREW 3.57	
11	114941001	1	ア-ムイトアンナイフェルト	FELT	
12	S15096000	1	シリンダ"クミ	CYLINDER ASSY	
12-1	S15097000	1	シリンダ"10X5	CYLINDER 10X5	
12-2	S15871000	1	スピ"コンツキ"テM5-4	SPEED CONTROLLER JOINT M5-4	
13	S30505001	2	ミツメイトカケクミ	THREAD RETAINER ASSY	
13-1	140527001	2	ミツメイトカケ	THREAD RETAINER	
13-2	150553003	2	ナツト5.95	NUT 5.95	

J. 糸切れ感知関係 / Thread breakage detector mechanism / Fadenbruchfühler /
Mécanisme du détecteur de cassure du fil / Mecanismo del sensor de cortes de hilo

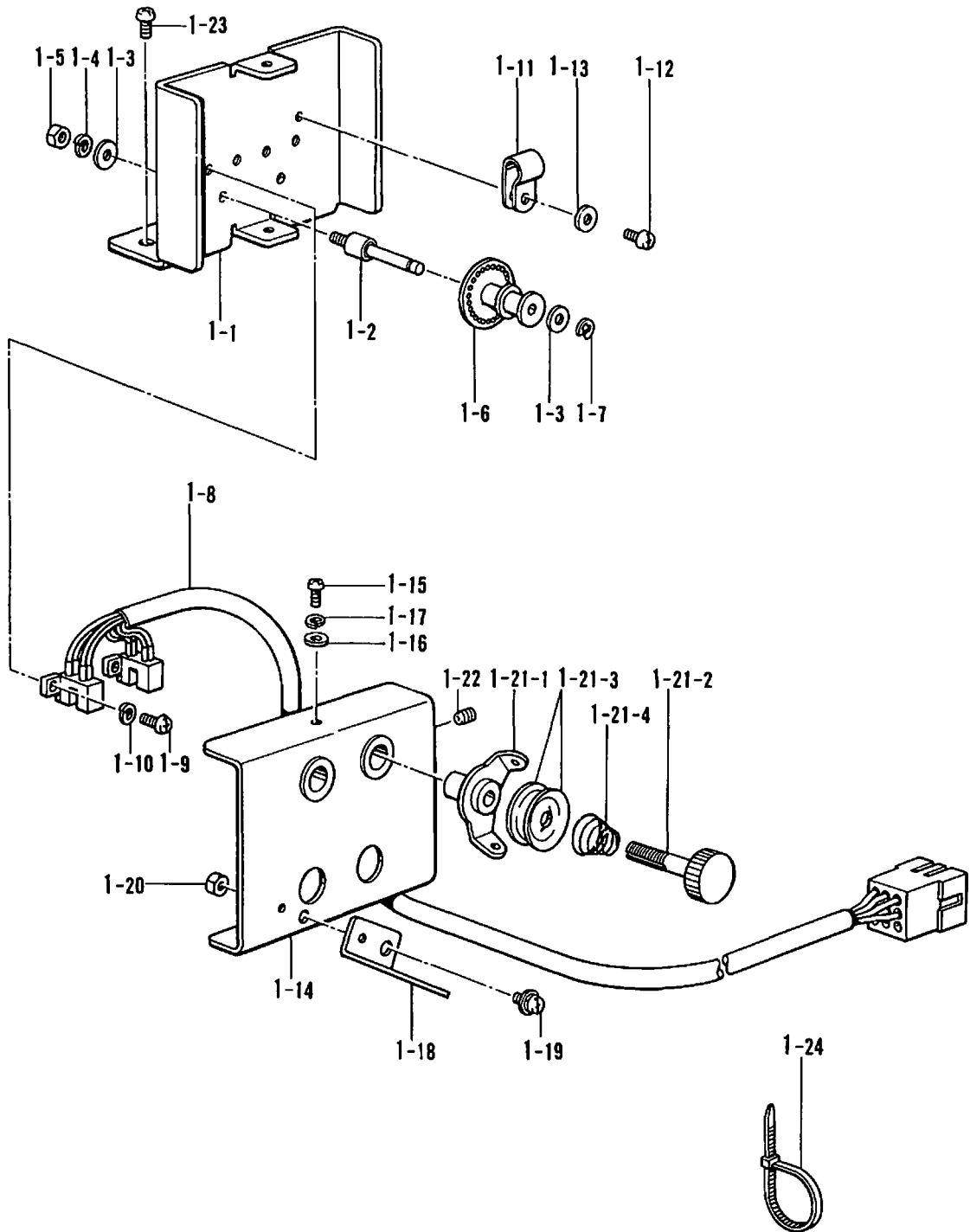

J. 糸切れ感知関係/Thread breakage detector mechanism/Fadenbruchfühler/
 Mécanisme du détecteur de cassure du fil/Mecanismo del sensor de cortes de hilo

REF.NO.	CODE	QTY	ヒンメイ	NAME OF PARTS	RMKS
1	S09399009	1	ウワイトキレケンチクミ	UPPER THREAD BREAKAGE SENSOR	
1-1	S09400009	1	トリツケタイ	SETTING BRACKET	
1-2	S09401001	2	シテンシク	FULCRUM SHAFT	
1-3	025030233	4	ヒラサ"ガ"ネチユウ3	PLAIN WASHER 3	
1-4	028030243	2	ハ"ネサ"ガ"ネ2-3	SPRING WASHER 2-3	
1-5	021300103	2	ナツト1シユ3	NUT 3	
1-6	S09402101	2	プーリー	PULLEY	
1-7	048020342	2	トメワE2	STOP RING E2	
1-8	S08117000	1	イトキレセンサークミ	THREAD BREAKAGE SENSOR ASSY	
1-9	062300616	4	ナヘ"コM3X6	SCREW M3X6	
1-10	028030243	4	ハ"ネサ"ガ"ネ2-3	SPRING WASHER 2-3	
1-11	S00480000	1	コート"ホルダ"#5	CORD HOLDER 5N	
1-12	062400616	1	ナヘ"コM4X6	SCREW M4X6	
1-13	025040233	1	ヒラサ"ガ"ネチユウ4	PLAIN WASHER 4	
1-14	S09403009	1	カハ-	COVER	
1-15	062300616	2	ナヘ"コM3X6	SCREW M3X6	
1-16	025030233	2	ヒラサ"ガ"ネチユウ3	PLAIN WASHER 3	
1-17	028030243	2	ハ"ネサ"ガ"ネ2-3	SPRING WASHER 2-3	
1-18	S03566001	1	メンイタイトカケ	FACE PLATE THREAD GUIDE	
1-19	052400806	1	ナヘ"コハ"ネヒラ4X8	WASHER SCREW 4X8	
1-20	021400202	1	2シユナツト4	NUT 4	
1-21	183377001	2	プレテンションクミA	PRE-TENSION ASSY (A)	
1-21-1	S02611001	2	イトアンナイ	THREAD GUIDE	
1-21-2	S02612001	2	イトアンナイチヨウシホ"ウ	PRE-TENSION STUD	
1-21-3	144504001	2	イトアンナイサラ	THREAD GUIDE DISC	
1-21-4	154560001	2	プレテンションハ"ネA	PRE-TENSION SPRING (A)	
1-22	014500522	2	アナトメネシ"5クホ"ミ	SET SCREW 5	
1-23	062761212	2	ナヘ"コ595-28X12	SCREW 595X12	
1-24	S04557000	1	パンタイPLTIM	BAND PLTIM	

K1. スタッカー関係 / Stacker mechanism / Anhäufung /
 Mécanisme de l'empileur / Mecanismo de apilador

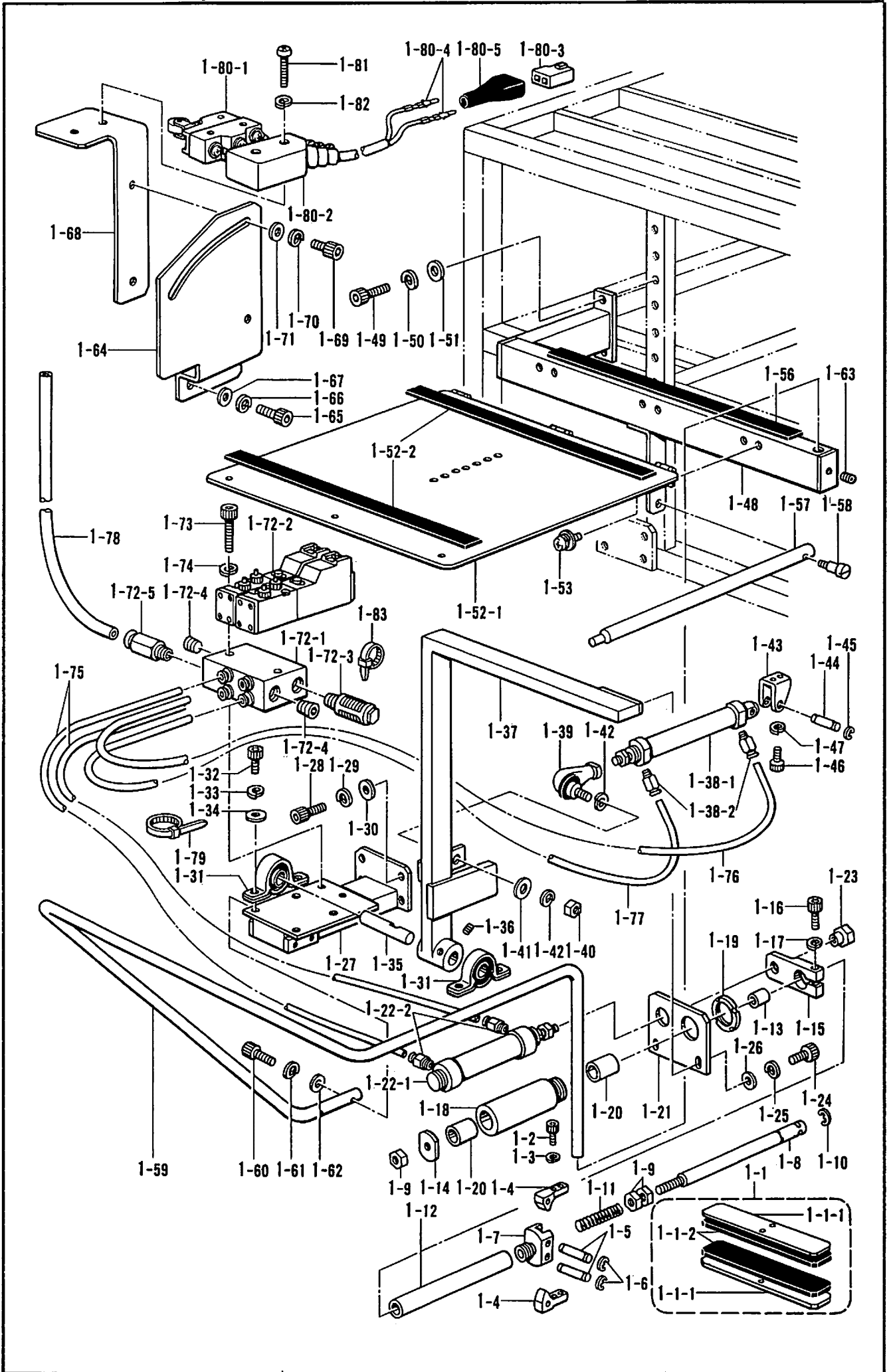

K1. スタッカ関係 / Stacker mechanism / Anhäufung /
Mécanisme de l'empileur / Mecanismo de apilador

REF.NO.	CODE	Q'TY	ヒンメイ	NAME OF PARTS	RMKS
1	S08431209	1	ツマミスタッククミ	PICK-UP TYPE STACKER ASSY	
1-1	S08363001	2	チャックアタマクミ	CHUCK HOLDER ASSY	
1-1-1	S08432001	2	チャックアタマ	CHUCK HOLDER	
1-1-2	S08433000	2	チャックゴム	CHUCK RUBBER	
1-2	018401036	4	アナボルト4X10	BOLT 4X10	
1-3	028040242	4	ハネサカネ2-4	SPRING WASHER 2-4	
1-4	S08434001	2	チャック	CHUCK	
1-5	S08435001	2	シテンジク	FULCRUM SHAFT	
1-6	048030342	4	トメワE3	STOP RING E3	
1-7	S08436001	1	チャックホルター	CHUCK HOLDER	
1-8	S08437001	1	カイヘイシク	OPENING AND CLOSING MOTION	
1-9	021080206	3	2シユナツト8	NUT 8	
1-10	048070342	1	トメワE7	STOP RING E7	
1-11	S08438001	1	アツシユクハネ	SPRING	
1-12	S08439001	1	スライシク	SLIDE SHAFT	
1-13	S08440000	1	トライハアリング	BUSH BM1015FB	
1-14	S08441001	1	ストツハ	STOPPER	
1-15	S08442001	1	レンケツイタ	CONNECTING PLATE	
1-16	018502036	1	アナボルト5X20	BOLT 5X20	
1-17	028050246	1	ハネサカネ2-5	SPRING WASHER 2-5	
1-18	S08443001	1	スライガイド	SLIDE GUIDE	
1-19	073050002	1	ジクウケナツトAN05	BEARING NUT AN05	
1-20	S08444000	2	トライハアリング	BUSH BM1825FB	
1-21	S08445001	1	トリツケイタ	SET PLATE	
1-22	S08446000	1	シリンタクミ	CYLINDER ASSY	
1-22-1	S08447000	1	シリンタ20X50	CYLINDER 20X50	
1-22-2	S29707000	2	コネクター4-1/8	CONNECTOR 4-1/8	
1-23	S08448001	1	ナツト	NUT	
1-24	018501636	2	アナボルト5X16	BOLT 5X16	
1-25	028050246	2	ハネサカネ2-5	SPRING WASHER 2-5	
1-26	025050236	2	ヒラサカネチユウ5	PLAIN WASHER 5	
1-27	S08450009	1	スタツカートタイ	STACKER BRACKET	
1-28	018082036	4	アナボルト8X20	BOLT 8X20	
1-29	028080246	4	ハネサカネ2-8	SPRING WASHER 2-8	
1-30	025080236	4	ヒラサカネチユウ8	PLAIN WASHER 8	
1-31	149342001	2	ヒロフブロック	PILLOW BLOCK	
1-32	018081236	4	アナボルト8X12	BOLT 8X12	
1-33	028080246	4	ハネサカネ2-8	SPRING WASHER 2-8	
1-34	025080236	4	ヒラサカネチユウ8	PLAIN WASHER 8	
1-35	S08514001	1	スタツカーシテンジク	STACKER FULCRUM SHAFT	
1-36	012060636	2	アナヒラ6X6	SET SCREW 6X6	
1-37	S08449009	1	スタツカーアーム	STACKER ARM	
1-38	S09406000	1	シリンタクミ	CYLINDER ASSY	
1-38-1	S09407000	1	シリンタ25X150	CYLINDER 25X150	
1-38-2	S29707000	2	コネクター4-1/8	CONNECTOR 4-1/8	
1-39	149487001	1	リンクボール	LINK BALL	
1-40	149488001	1	ロツトナツト	ROD NUT	
1-41	025100236	1	ヒラサカネチユウ10	PLAIN WASHER 10	
1-42	028100246	2	ハネサカネ2-10	SPRING WASHER 2-10	
1-43	S09618001	1	シリンタトリツケカナク	CYLINDER FITTING CLAMP	
1-44	S09619001	1	シリンタトリツケピン	PIN	
1-45	048050342	2	トメワE5	STOP RING E5	
1-46	018501636	2	アナボルト5X16	BOLT 5X16	
1-47	028050246	2	ハネサカネ2-5	SPRING WASHER 2-5	
1-48	S15061009	1	キジタイアーム	CLOTH STACKER ARM	
1-49	018082036	2	アナボルト8X20	BOLT 8X20	
1-50	028080246	2	ハネサカネ2-8	SPRING WASHER 2-8	
1-51	025080236	2	ヒラサカネチユウ8	PLAIN WASHER 8	
1-52	S08398009	1	スタツカーテーブルクミ	STACKER TABLE ASSY	
1-52-1	S08458009	1	スタツカーテーブル	STACKER TABLE	
1-52-2	S08459000	2	スタツカーテーブルゴム	STACKER TABLE RUBBER	
1-53	052400806	6	ナヘコハネヒラ4X8	WASHER SCREW 4X8	

K1. スタッカー関係 / Stacker mechanism / Anhäufung /
 Mécanisme de l'empileur / Mecanismo de apilador

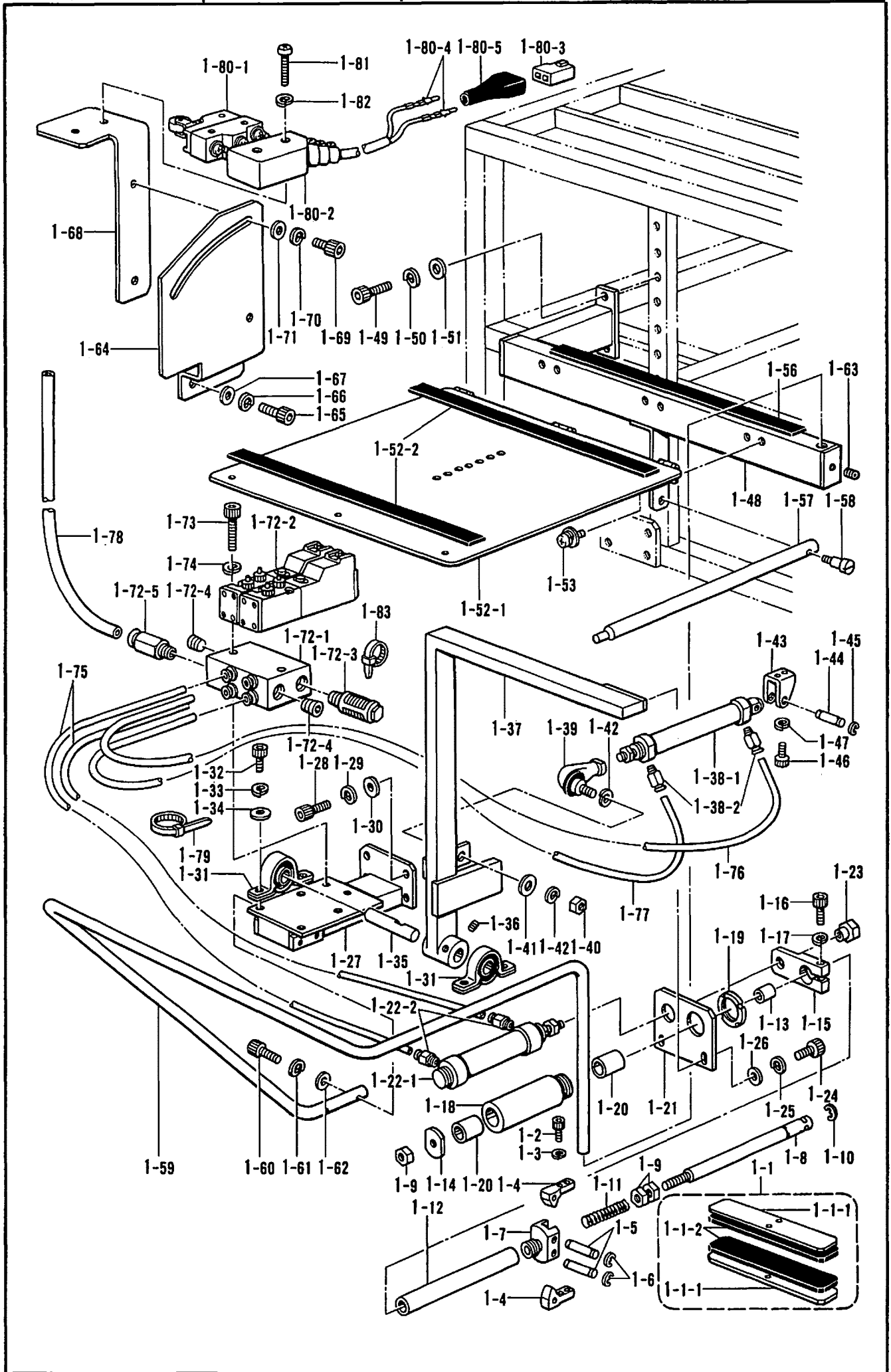

K1. スタッカー関係 / Stacker mechanism / Anhäufung /
 Mécanisme de l'empileur / Mecanismo de apilador

REF.NO.	CODE	Q'TY	ヒンメイ	NAME OF PARTS	RMKS
1-56	S08459000	1	スタッカーテーブルゴム	STACKER TABLE RUBBER	
1-57	S08460001	1	テーブルササエ棒	TABLE SUPPORT BAR	
1-58	147933001	1	タ"ンネシ"5.95	STUD SCREW 5.95	
1-59	S15062009	1	ガード"バー	GUARD BAR	
1-60	018062536	2	アナホルト6X25	BOLT 6X25	
1-61	028060246	2	ハ"ネサ"カ"ネ2-6	SPRING WASHER 2-6	
1-62	025060236	2	ヒラサ"カ"ネチユウ6	PLAIN WASHER 6	
1-63	012500536	1	アナヒラ5X5	SET SCREW 5X5	
1-64	S08470009	1	スタッカースイッチタ"イ	STACKER SWITCH BASE	
1-65	018061636	2	アナホルト6X16	BOLT 6X16	
1-66	028060246	2	ハ"ネサ"カ"ネ2-6	SPRING WASHER 2-6	
1-67	025060236	2	ヒラサ"カ"ネチユウ6	PLAIN WASHER 6	
1-68	S08471009	1	スタッカースイッチレ"バー	STACKER SWITCH LEVER	
1-69	018501036	2	アナホ"ルト5X10	BOLT 5X10	
1-70	028050246	2	ハ"ネサ"カ"ネ2-5	SPRING WASHER 2-5	
1-71	025050236	2	ヒラサ"カ"ネチユウ-5	PLAIN WASHER 5	
1-72	S08135001	1	ハ"ルプ"ユニットSTK	VALVE UNIT	
1-72-1	S08151000	1	マニホルト"S-2	MANIFOLD S-2	
1-72-2	S08154000	2	ハ"ルプ"VZ3150	VALVE VZ3150	
1-72-3	140682001	1	サイレンサン	SILENCER	
1-72-4	153274001	2	1/8トメセン	CAP 1/8	
1-72-5	S08152000	1	ハーフユニオン1/8-8	HALF UNION 1/8-8	
1-73	018503036	2	アナホ"ルト5X30	BOLT 5X30	
1-74	028050246	2	ハ"ネサ"カ"ネ2-5	SPRING WASHER 2-5	
1-75	S08138000	2	エア-ホ-スS-A	AIR TUBE S-A (L=1030)	
1-76	S08139000	1	エア-ホ-スS-B	AIR TUBE S-B (L=420)	
1-77	S08140000	1	エア-ホ-スS-C	AIR TUBE S-C (L=200)	
1-78	S08361000	1	エア-ホ-ス8-B	AIR TUBE 8-B (L=1050)	
1-79	S04557000	5	ハ"ンタイPLTIM	BAND PLTIM	
1-80	S08127001	1	リミットスイッチクミ	LIMIT SWITCH ASSY	
1-80-1	S08131000	1	リミットスイッチ	LIMIT SWITCH	
1-80-2	147926000	1	マイクロスイッチカハ"ー	MICRO SWITCH COVER	
1-80-3	S08007000	1	コネクタ5025-02P1	CONNECTOR (5025-02P1)	
1-80-4	S08017000	2	オスピン5006TL	PIN	
1-80-5	143489001	1	コネクタキャツ"プ	CONNECTOR CAP	
1-81	002402502	2	プ"ラスナヘ"ネシ"4X25	SCREW 4X25	
1-82	028040246	2	ハ"ネサ"カ"ネ2-4	SPRING WASHER 2-4	
1-83	149809000	3	タイラツ"プL	BEAD BAND (L)	

K2. スタッカー関係 / Stacker mechanism / Anhäufung /
 Mécanisme de l'empileur / Mecanismo de apilador

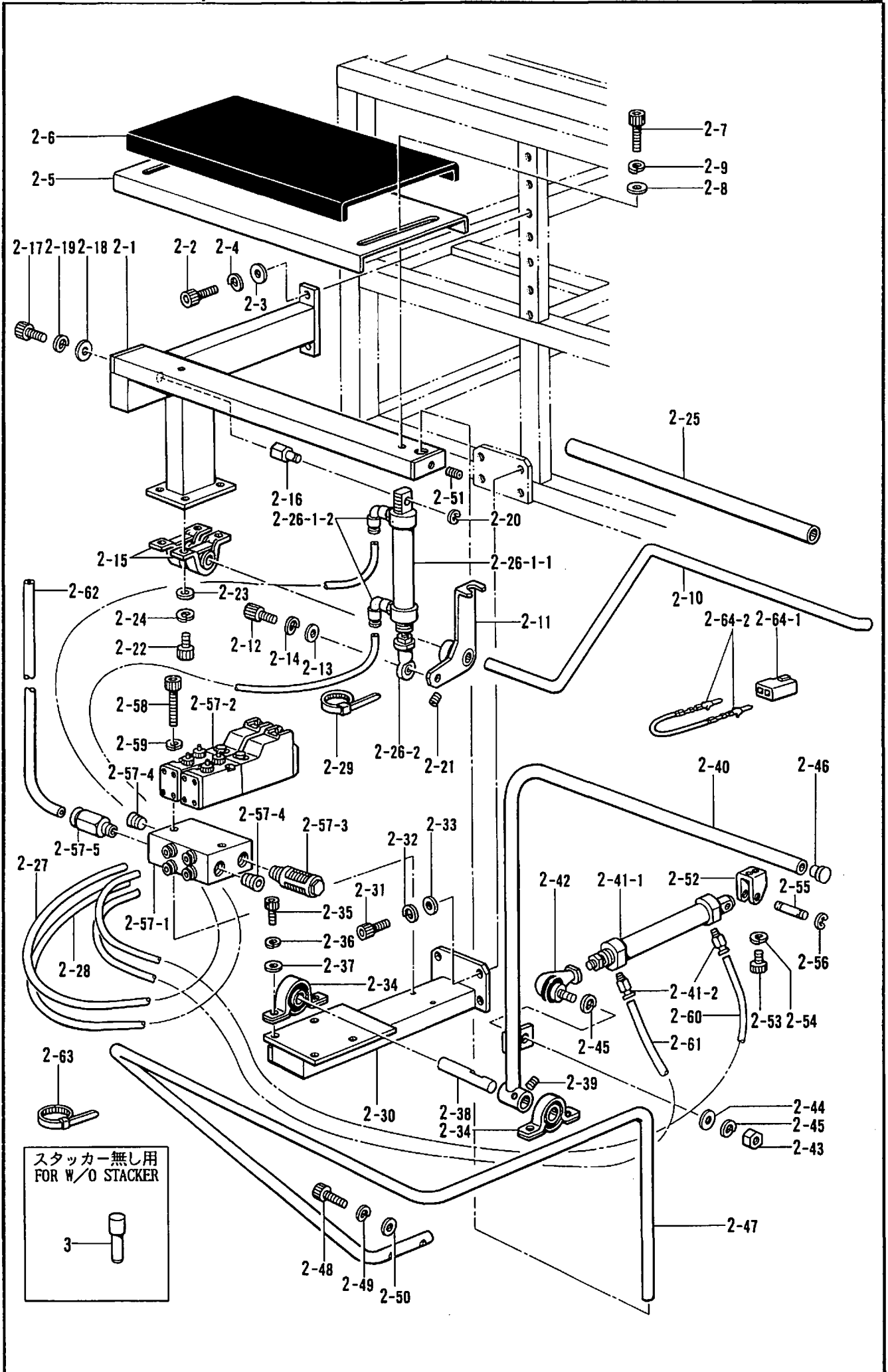

K2. スタッカー関係 / Stacker mechanism / Anhäufung /
Mécanisme de l'empileur / Mecanismo de apilador

REF.NO.	CODE	Q'TY	ヒンメイ	NAME OF PARTS	RMKS
2	S33260009	1	ハーススタッカークミ	BAR STACKER ASSY	
2-1	S15063009	1	ハーススタッカーキシタイ	BAR STACKER CLOTH BASE	
2-2	018082036	2	アナボルト8X20	BOLT 8X20	
2-3	025080236	2	ヒラサカネチユウ8	PLAIN WASHER 8	
2-4	028080246	2	ハネサカネ2-8	SPRING WASHER 2-8	
2-5	S06736009	1	スタッカーウケイタ	STACKER PLATE	
2-6	S06737000	1	スタッカスポンシL	PACKING (L)	
2-7	S31814001	2	アナボルト5X40	BOLT 5X40	
2-8	025050236	2	ヒラサカネチユウ5	PLAIN WASHER 5	
2-9	028050246	2	ハネサカネ2-5	SPRING WASHER 2-5	
2-10	S33250001	1	スタッカーバーL	STACKER BAR (L)	
2-11	S06739009	1	スタッカーウデL	STACKER ARM (L)	
2-12	018082536	1	アナボルト8X25	BOLT 8X25	
2-13	025080236	1	ヒラサカネチユウ8	PLAIN WASHER 8	
2-14	028080246	1	ハネサカネ2-8	SPRING WASHER 2-8	
2-15	S06740001	2	ヘアリングASPP202	BAR SUPPORT ASPP202	
2-16	S06741001	1	シリンダトメカナク	CYLINDER STUD	
2-17	018081236	1	アナボルト8X12	BOLT 8X12	
2-18	025080236	1	ヒラサカネチユウ8	PLAIN WASHER 8	
2-19	028080246	1	ハネサカネ2-8	SPRING WASHER 2-8	
2-20	048060342	1	トメワE6	STOP RING E6	
2-21	012500536	2	アナヒラ5X5	SET SCREW 5X5	
2-22	151163001	4	アナボルト8X15	BOLT 8X15	
2-23	025080236	4	ヒラサカネチユウ8	PLAIN WASHER 8	
2-24	028080246	4	ハネサカネ2-8	SPRING WASHER 2-8	
2-25	S06744000	1	チューブL	TUBE (L) (L=420)	
2-26-1	S11685000	1	シリンダクミ	CYLINDER ASSY	
2-26-1-1	S06897000	1	シリンダ20X75	CYLINDER 20X75	
2-26-1-2	S06886000	2	ツキテ1/8-4	JOINT 1/8-4	
2-26-2	S08352000	1	ロッドエンド	ROD END	
2-27	S08125000	1	エアホース4-S1	AIR TUBE 4-S1 (L=410)	
2-28	S08126000	1	エアホース4-S2	AIR TUBE 4-S2 (L=560)	
2-29	S04557000	2	バンドPLTIM	BAND PLTIM	
2-30	S15065009	1	スタッカートタイ	STACKER BRACKET	
2-31	018082036	4	アナボルト8X20	BOLT 8X20	
2-32	028080246	4	ハネサカネ2-8	SPRING WASHER 2-8	
2-33	025080236	4	ヒラサカネチユウ8	PLAIN WASHER 8	
2-34	149342001	2	ピロブロック	PILLOW BLOCK	
2-35	018081236	4	アナボルト8X12	BOLT 8X12	
2-36	028080246	4	ハネサカネ2-8	SPRING WASHER 2-8	
2-37	025080236	4	ヒラサカネチユウ8	PLAIN WASHER 8	
2-38	S08514001	1	スタッカーシテンシク	STACKER FULCRUM SHAFT	
2-39	012060636	2	アナヒラ6X6	SET SCREW 6X6	
2-40	S15066009	1	スタッカーバー	STACKER BAR	
2-41	S09406000	1	シリンダクミ	CYLINDER ASSY	
2-41-1	S09407000	1	シリンダ25X150	CYLINDER 25X150	
2-41-2	S29707000	2	コネクター4-1/8	CONNECTOR 4-1/8	
2-42	149487001	1	リンクボール	LINK BALL	
2-43	149488001	1	ロッドナット	ROD NUT	
2-44	025100236	1	ヒラサカネチユウ10	PLAIN WASHER 10	
2-45	028100246	2	ハネサカネ2-10	SPRING WASHER 2-10	
2-46	117934009	1	メクラセン	OIL CAP	
2-47	S15062009	1	ガードバー	GUARD BAR	
2-48	018062536	2	アナボルト6X25	BOLT 6X25	
2-49	028060246	2	ハネサカネ2-6	SPRING WASHER 2-6	
2-50	025060236	2	ヒラサカネチユウ6	PLAIN WASHER 6	
2-51	012500536	1	アナヒラ5X5	SET SCREW 5X5	
2-52	S09618001	1	シリンダトリツケカナク	CYLINDER FITTING CLAMP	
2-53	018501636	2	アナボルト5X16	BOLT 5X16	
2-54	028050246	2	ハネサカネ2-5	SPRING WASHER 2-5	
2-55	S09619001	1	シリンダトリツケピン	PIN	
2-56	048050342	2	トメワE5	STOP RING E5	

K2. スタッカー関係 / Stacker mechanism / Anhäufung /
 Mécanisme de l'empileur / Mecanismo de apilador

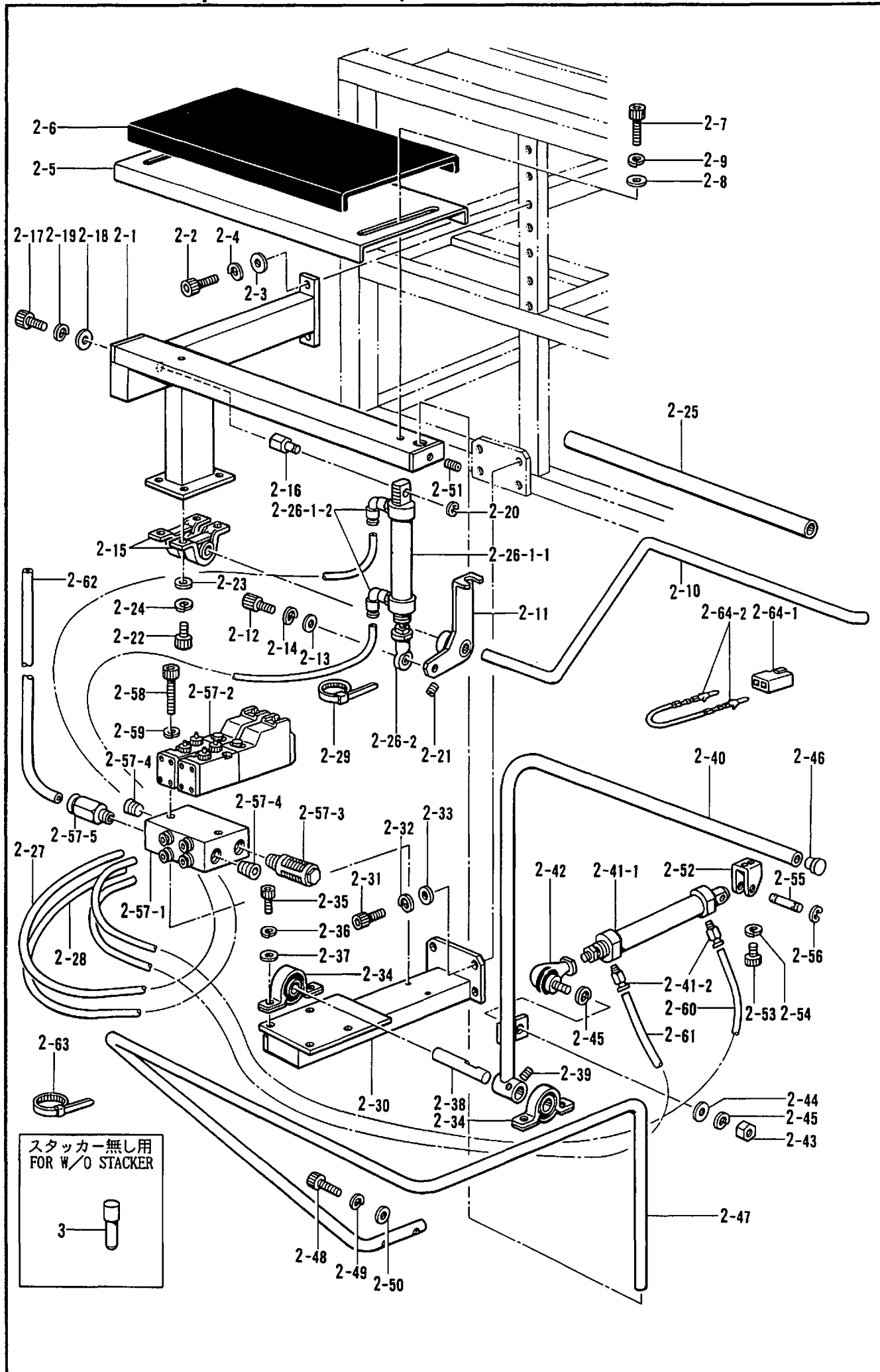

K2. スタッカー関係 / Stacker mechanism / Anhäufung /
 Mécanisme de l'emplieur / Mecanismo de apilador

REF.NO.	CODE	Q'TY	ヒンメイ	NAME OF PARTS	RMKS
2-57	S08135001	1	ハ"ルフ"ユニットSTK	VALVE UNIT	
2-57-1	S08151000	1	マニホルト"S-2	MANIFOLD S-2	
2-57-2	S08154000	2	ハ"ルフ"VZ3150	VALVE VZ3150	
2-57-3	140682001	1	サイレンサン	SILENCER	
2-57-4	153274001	2	1/8トメセン	CAP 1/8	
2-57-5	S08152000	1	ハーフユニオン1/8-8	HALF UNION 1/8-8	
2-58	018503036	2	アナボ"ルト5X30	BOLT 5X30	
2-59	028050246	2	ハ"ネサ"カ"ネ2-5	SPRING WASHER 2-5	
2-60	S08139000	1	エア"ホースS-B	AIR TUBE S-B (L=420)	
2-61	S08140000	1	エア"ホースS-C	AIR TUBE S-C (L=200)	
2-62	S08361000	1	エア"ホース8-B	AIR TUBE 8-B (L=1050)	
2-63	S04557000	4	ハ"ンタイPLTIM	BAND PLTIM	
2-64	S08130000	1	コネクタ2Pクミ	CONNECTOR (2P) ASSY	
2-64-1	S08007000	1	コネクタ5025-02P1	CONNECTOR (5025-02P1)	
2-64-2	S08017000	2	オスピン5006TL	PIN	
3	S08134000	1	<スタッカーナシヨウ> トメセン8	<FOR W/O STACKER> CAP 8	

L. 糸巻関係/Bobbin winder mechanism/Spuler/
 Mécanisme du bobineur/Mecanismo del devanador de la canilla

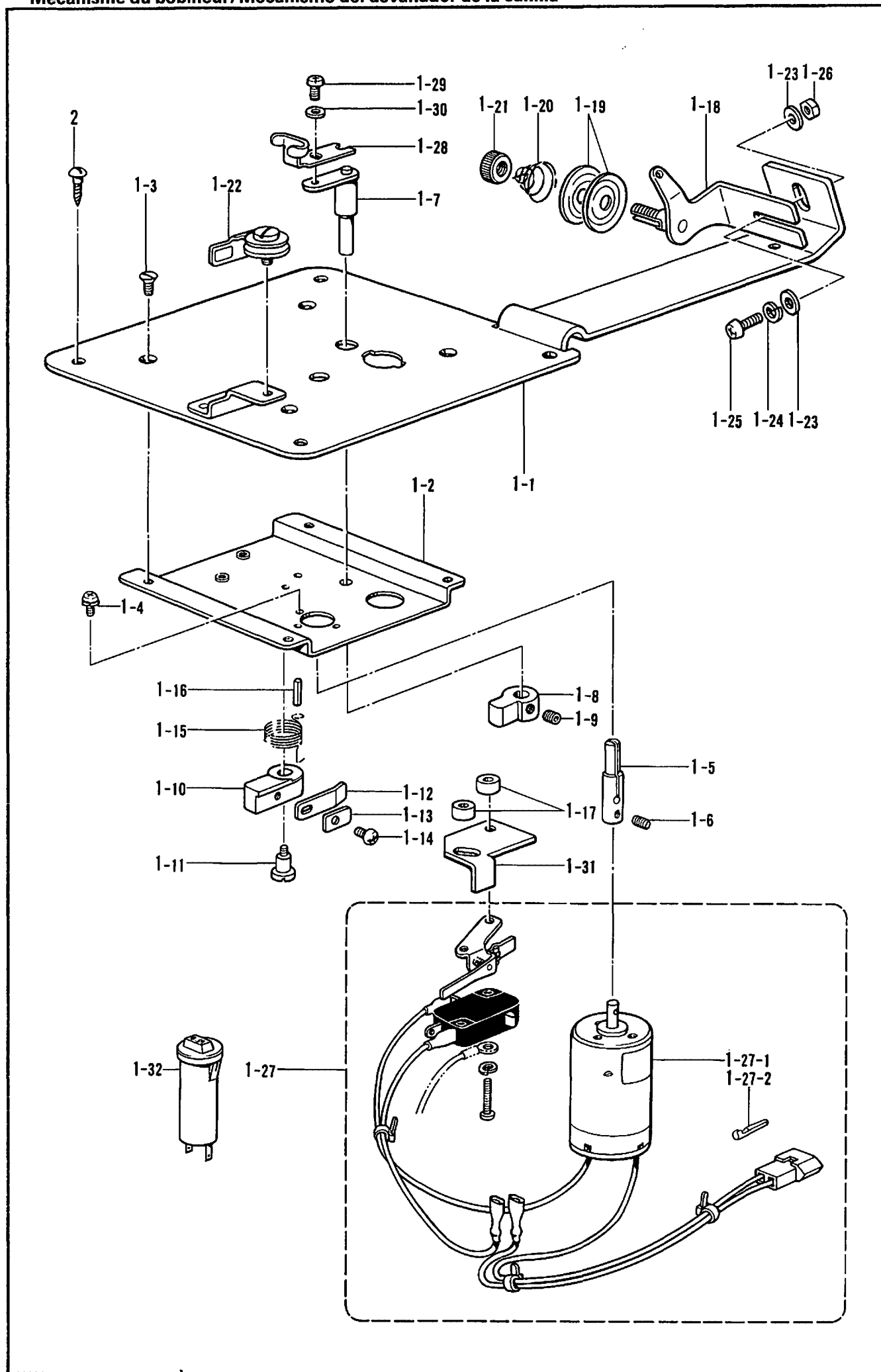

L. 糸巻関係/Bobbin winder mechanism/Spuler/

Mécanisme du bobineur/Mecanismo del devanador de la canilla

REF.NO.	CODE	Q'TY	ヒンメイ	NAME OF PARTS	RMKS
1	152651301	1	イトマキソウチクミ	BOBBIN WINDER ASSY	
1-1	152356301	1	イトマキト"ダイ	BOBBIN WINDER BASE	
1-2	152357101	1	イトマキモータジジ"イタ	BOBBIN WINDER MOTOR INDICATE	
1-3	004300513	4	+ サラコ3X5	SCREW 3X5	
1-4	215083001	3	+ ナヘ"セツト3X6D	WASHER SCREW 3X6D	
1-5	152358001	1	イトマキジ"ク	BOBBIN WINDER SHAFT	
1-6	014300332	2	アナクホ"ミ3X3	SET SCREW 3X3	
1-7	154024001	1	ホ"ヒ"ンオサイ	BOBBIN PRESSER	
1-8	154092001	1	イトマキツキタ"ンツキ	BOBBIN WINDER CLAW	
1-9	014680422	2	アナトメネジ"4.37クホ"ミ	SET SCREW 4.37	
1-10	152361001	1	イトマキレハ"ー	BOBBIN WINDER LEVER	
1-11	152362001	1	イトマキタ"ンネジ"	BOBBIN WINDER STUD SCREW	
1-12	111942001	1	イタハ"ネ	PLATE SPRING	
1-13	111943001	1	イタハ"ネサ"カ"ネ	PLATE SPRING WASHER	
1-14	060660512	1	ハ"イント"318-40X5	SCREW 318X5	
1-15	152363001	1	ネジ"リハ"ネA	TWIST SPRING (A)	
1-16	047301042	1	スプリング"ピン	SPRING PIN	
1-17	152364001	2	カラー	COLLAR	
1-18	145571101	1	イトマキアンナイタ"イクミ	BOBBIN WINDER GUIDE BRACKET	
1-19	145446001	2	イトチヨウシサラ	TENSION DISC	
1-20	100401001	1	イトチヨウシハ"ネ	TENSION SPRING	
1-21	100136001	1	イトチヨウシナツト	TENSION NUT	
1-22	146197001	1	イトツカミクミ	THREAD CLAMP ASSY	
1-23	025040233	2	ヒラサ"カ"ネチユウ4	PLAIN WASHER 4	
1-24	028040243	1	ハ"ネサ"カ"ネ2-4	SPRING WASHER 2-4	
1-25	062401006	1	ナヘ"コ4X10	SCREW 4X10	
1-26	021400103	1	ナツト1シユ4	NUT 4	
1-27	S21203001	1	イトマキモータクミ	BOBBIN WINDER MOTOR ASSY	
1-27-1	S16667000	1	イトマキモータ	BOBBIN WINDER MOTOR	
1-27-2	552851001	2	ヒンターミナル#1854	TERMINAL PIN #1854	
1-28	152645001	1	ホ"ヒ"ンオサイイタ	BOBBIN HOLD PLATE	
1-29	062300616	1	ナヘ"コM3X6	SCREW M3X6	
1-30	025030233	1	ヒラサ"カ"ネチユウ3	PLAIN WASHER 3	
1-31	158597001	1	イトマキストツハ"ー	BOBBIN WINDER STOPPER	
1-32	S16669000	1	プロテクタ0.5A	PROTECTOR 0.5A	
2	032311306	5	+ マルモクネジ"3.1X13	SCREW 3.1X13	

M. 糸切り関係/Thread trimmer mechanism/Fadenabschneidevorrichtung/
Mécánisme de coupe-fill/Mecanismo de la cortadura de hilos

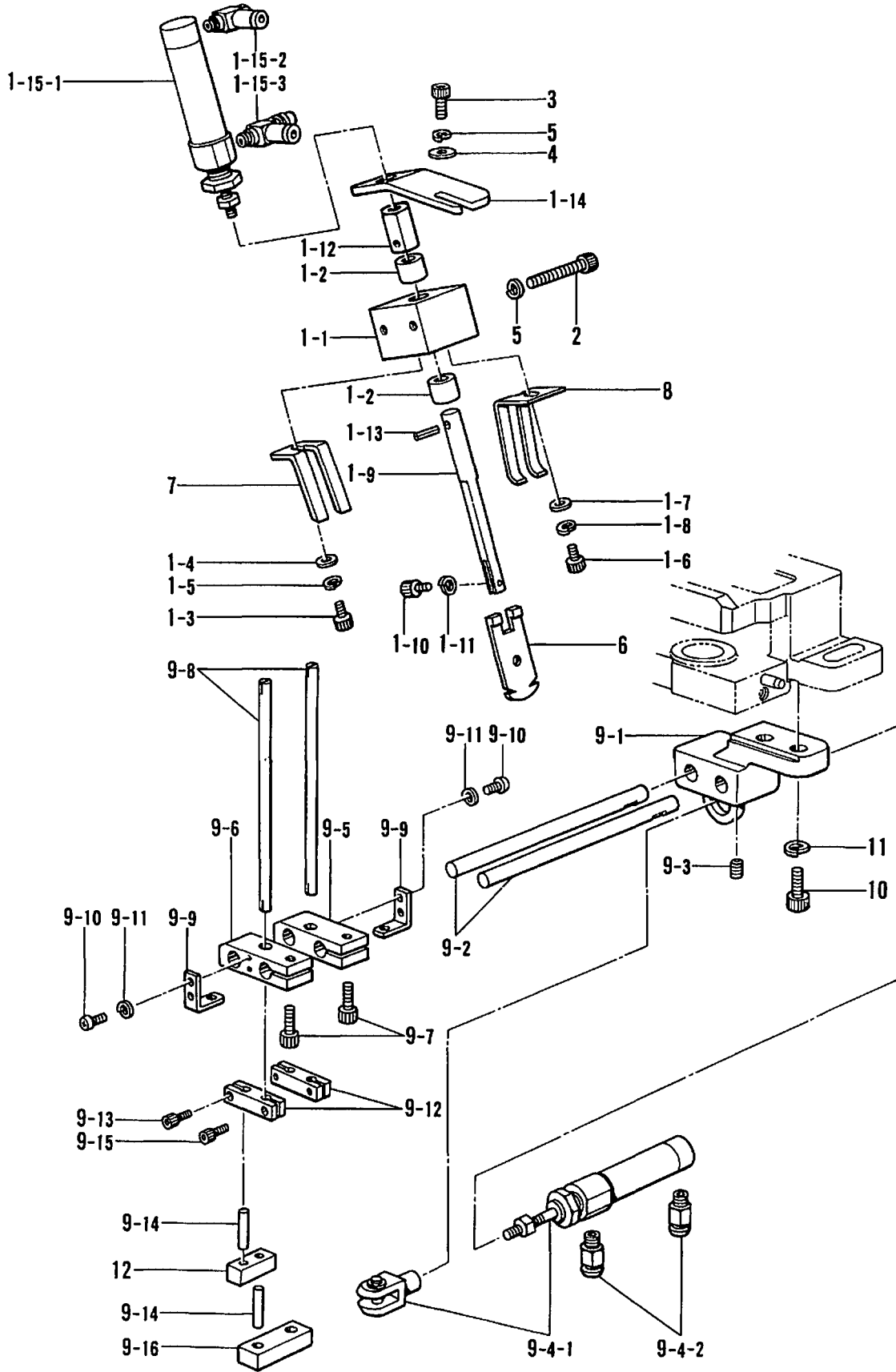

M. 糸切り関係/Thread trimmer mechanism/Fadenabschneidevorrichtung/
 Mécanisme de coupe-fill/Mecanismo de la cortadura de hilos

REF.NO.	CODE	Q'TY	ヒンメイ	NAME OF PARTS	RMKS
1	S31204009	1	ウフイトメスクミ	UPPER THREAD KNIFE ASSY	
1-1	S14689001	1	メスホ"ウカ"イト"	KNIFE BAR GUIDE	
1-2	S08397000	2	ト"ライヘ"アリング"	BUSH BM0808FB	
1-3	018300836	1	アナホ"ルト3X8	BOLT 3X8	
1-4	025030133	1	ヒラサ"カ"ネシヨウ3	PLAIN WASHER 3	
1-5	028030246	1	ハ"ネサ"カ"ネ2-3	SPRING WASHER 2-3	
1-6	018300836	1	アナホ"ルト3X8	BOLT 3X8	
1-7	025030133	1	ヒラサ"カ"ネシヨウ3	PLAIN WASHER 3	
1-8	028030246	1	ハ"ネサ"カ"ネ2-3	SPRING WASHER 2-3	
1-9	S14802001	1	メスホ"ウ	KNIFE BAR	
1-10	018300836	1	アナホ"ルト3X8	BOLT 3X8	
1-11	028030246	1	ハ"ネサ"カ"ネ2-3	SPRING WASHER 2-3	
1-12	S14690001	1	ツキ"テ	JOINT	
1-13	047301242	1	スフ"リンク"ヒ"ンAW3	SPRING PIN AW3	
1-14	S14691009	1	シリンダ"ダイ	CYLINDER BRACKET	
1-15	S31205000	1	シリンダ"クミ	CYLINDER ASSY	
1-15-1	S08407000	1	シリンダ"16X30	CYLINDER 16X30	
1-15-2	S03820000	1	エルホ"M5	ELBOW M5	
1-15-3	S04592000	1	スピ"コン	SPEED CONTROLLER	
2	018403036	2	アナホ"ルト4X30	BOLT 4X30	
3	018401036	2	アナホ"ルト4X10	BOLT 4X10	
4	025040236	4	ヒラサ"カ"ネチユウ4	PLAIN WASHER 4	
5	028040246	4	ハ"ネサ"カ"ネ2-4	SPRING WASHER 2-4	
6	*	1	ウフイトメス	MOVABLE KNIFE	
7	*	1	コ"テイハ	FIXED KNIFE	
8	*	1	イトホジ"ハ"ネ	SPRING	
9	S16147001	1	シタイトメスクミ	LOWER THREAD KNIFE ASSY	
9-1	S14692001	1	メスト"ダイ	KNIFE BASE	
9-2	S08377001	2	ガ"イト"ジ"ク	GUIDE SHAFT	
9-3	014400422	2	アナトメネジ"4X4クホ"ミ	SET SCREW 4X4	
9-4	S08387000	1	シリンダ"クミ	CYLINDER ASSY	
9-4-1	S08388000	1	シリンダ"16X15	CYLINDER 16X15	
9-4-2	S06882000	2	ツキ"テM5-4	JOINT M5-4	
9-5	S14693001	1	メスホルタ"R	KNIFE HOLDER (R)	
9-6	S14694001	1	メスホルタ"L	KNIFE HOLDER (L)	
9-7	018401222	2	アナホ"ルト4X12	BOLT 4X12	
9-8	S08381001	2	メス	KNIFE	
9-9	S08382001	2	ストツハ"	STOPPER	
9-10	062300616	4	ナヘ"コM3X6	SCREW M3X6	
9-11	028030243	4	ハ"ネサ"カ"ネ2-3	SPRING WASHER 2-3	
9-12	S08383001	2	リンクA	LINK (A)	
9-13	018300622	2	アナホ"ルト3X6	BOLT 3X6	
9-14	S08384001	2	ジ"ク4X19.8	SHAFT 4X19.8	
9-15	018300622	2	アナホ"ルト3X6	BOLT 3X6	
9-16	S08386001	1	リンクC	LINK (C)	
10	018501622	2	アナホ"ルト5X16	BOLT 5X16	
11	028050242	2	ハ"ネサ"カ"ネ2-5	SPRING WASHER 2-5	
12	*	1	リンクB	LINK (B)	

N. コントロールボックス関係 / Control box mechanism / Schaltkasten /
Mécanisme du boîtier de contrôle / Mecanismo del caja de controles

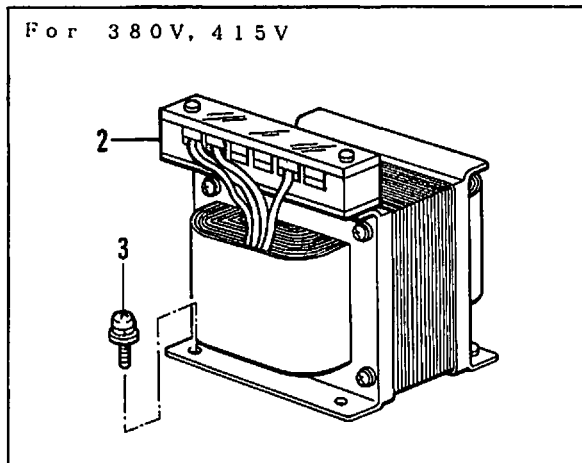
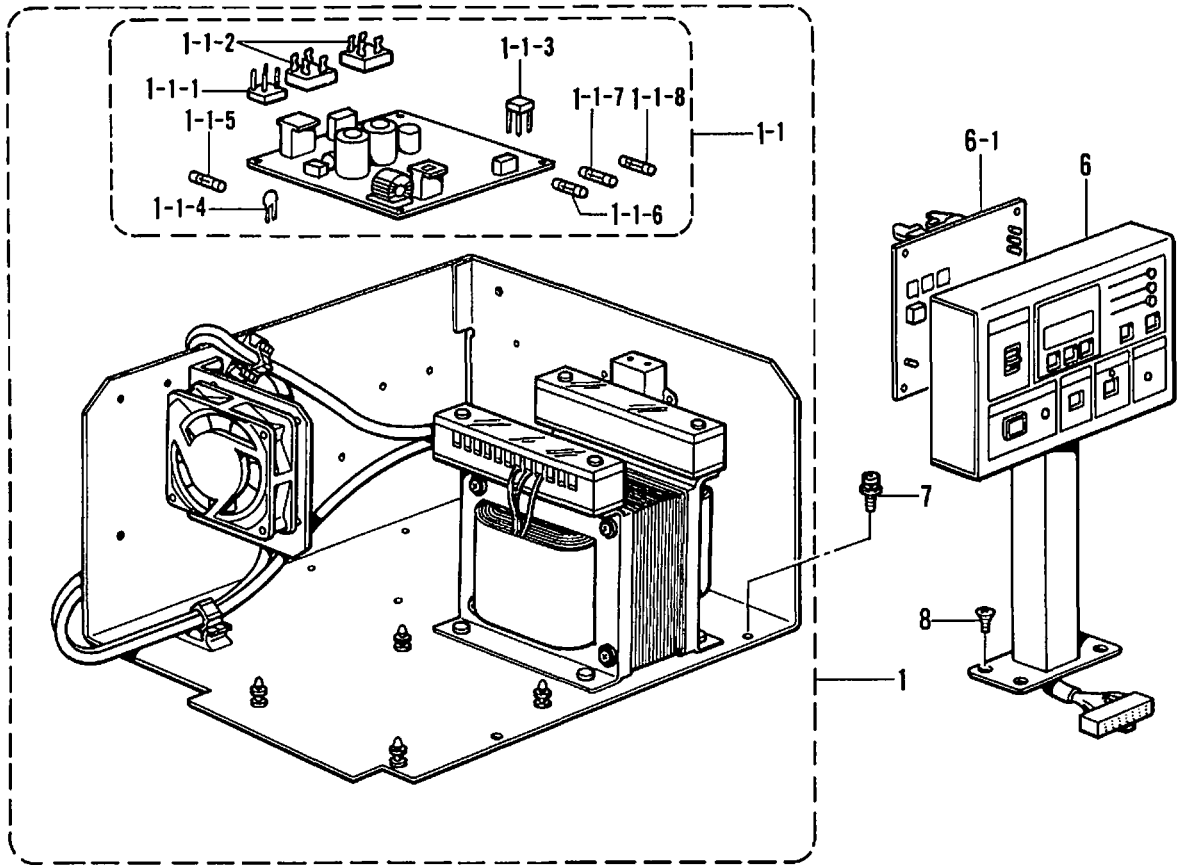

N. コントロールボックス関係/Control box mechanism/Schaltkasten/
 Mécanisme du boîtier de contrôle/Mecanismo del caja de controles

REF.NO.	CODE	Q'TY	ヒンメイ	NAME OF PARTS	RMKS
1	S31740001	1	デ"ンゲ"ンユニットクミ	POWER UNIT ASSY	
1-1	S31912001	1	キハ"ンB43K008クミ	CIRCUIT BOARD (B43K008) ASSY	
1-1-1	S08032000	1	SIBRS10VB60	SIBRS10VB60	
1-1-2	S10315000	2	SIBRS15VB10	SIBRS15VB10	
1-1-3	S30224000	1	SIDS3WB10	SIDS3W10	
1-1-4	S30227000	1	ZNRC20DK391	ZNRC20DK391	
1-1-5	S08030000	1	Gヒューズ"5AFB	G FUSE (5AFB)	
1-1-6	219225000	1	カンヒューズ"8A	FUSE (8A)	
1-1-7	152565000	1	ヒューズ"B	FUSE (B)	
1-1-8	152566000	1	ヒューズ"C	FUSE (C)	
6	S31206009	1	ソウサホ"ツクスクミ	OPERATION BOX ASSY	
6-1	S30085000	1	キハ"ンB43N005クミ	CIRCUIT BOARD (B43N005) ASSY	
7	052400806	5	ナヘ"コハ"ネヒラ4X8	WASHER SCREW 4X8	
8	149320001	4	アナツキサラホ"ルトM6X40	BOLT M6X40	
2	S31755000	1	-----	<FOR 380V,415V> CONVERSION TRANSFORMER (C) ASSY	
3	0A5501006	4	-----	WASHER SCREW 5X10DB	

P. 空圧関係/Air pressure mechanism/Luftdruck/
 Mécanisme de la pression d'air/Mecanismo de la presión de aire

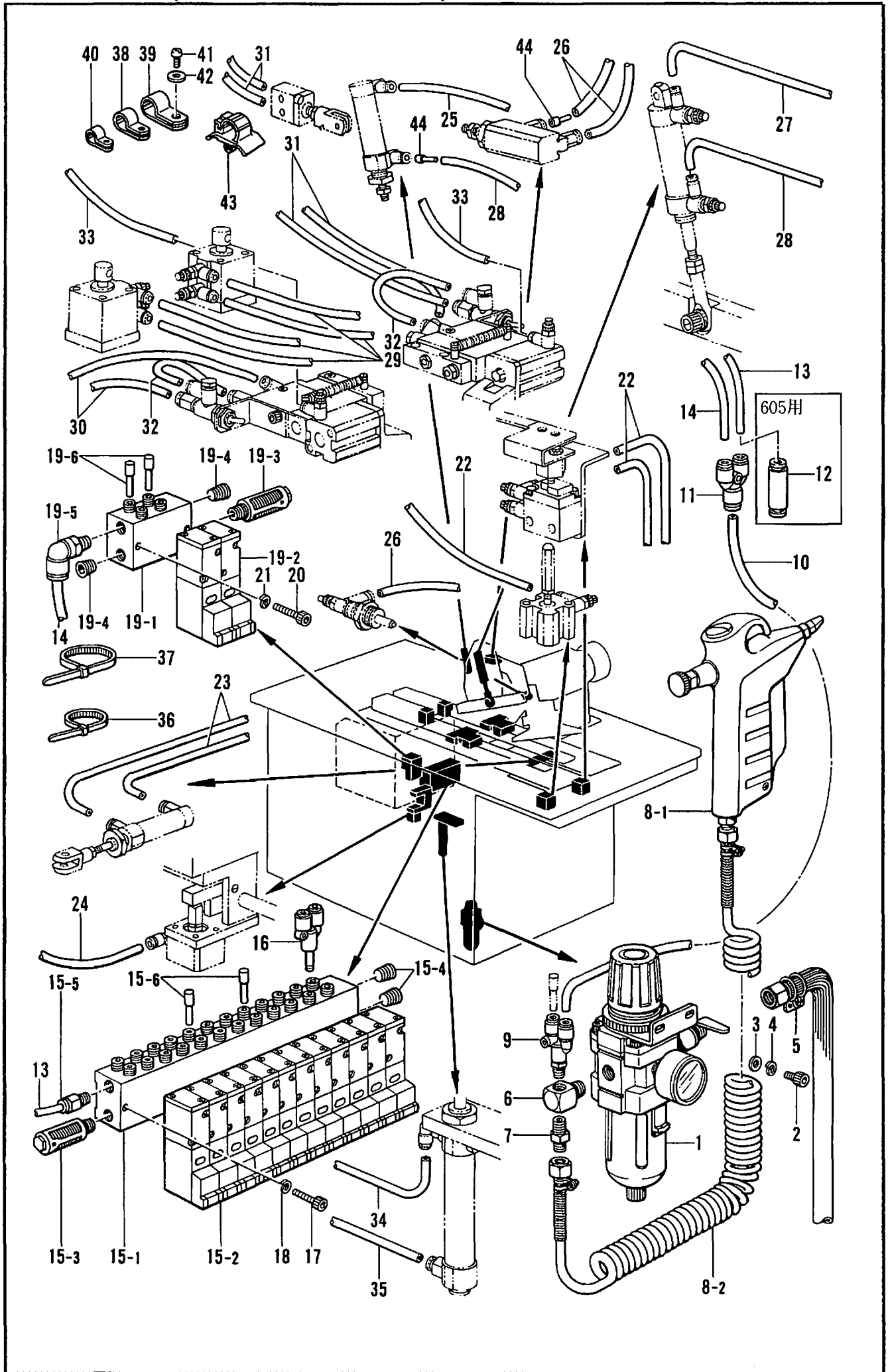

P. 空圧関係/Air pressure mechanism/Luftdruck/
Mécanisme de la pression d'air/Mecanismo de la presión de aire

REF.NO.	CODE	Q'TY	ヒンメイ	NAME OF PARTS	RMKS
1	S16162000	1	エアユニット	AIR UNIT ASSY	
2	018061236	2	アナホルト6X12	BOLT 6X12	
3	025060233	2	ヒラサ"ガ"ネチユウ6	WASHER 6	
4	028060243	2	ハ"ネサ"ガ"ネ2-6	SPRING WASHER 2-6	
5	149796001	1	ゴムホースカナグ"ツキ	AIR TUBE WITH CONNECTOR	
6	153252000	1	PTチース"	PT-JOINT	
7	S04891000	1	チユウカンニツプ"ル1/4	MIDDLE NIPPLE 1/4	
8	S06857000	1	エアガンクミ	AIR GUN ASSY	
8-1	S06858000	1	エアガン	AIR GUN	
8-2	S06859000	1	カールホース	CURL TUBE	
9	S08143000	1	ブランチY1/4-8	BRANCH Y 1/4-8	
10	S08144000	1	エアホース8-A	AIR TUBE 8-A (L=720)	
13	S08146000	1	エアホース6-A	AIR TUBE 6-A (L=135)	
15	S15076101	1	ハ"ルブ"ユニット	VALVE UNIT	
15-1	S15077000	1	マニホルト"S-12	MANIFOLD S-12	
15-2	S08155000	12	ハ"ルブ"VZ3140	VALVE VZ3140	
15-3	140682001	1	サイレンサン	SILENCER	
15-4	153274001	2	1/8トメセン	CAP 1/8	
15-5	S01522000	1	ハーフユニオン	HALF UNION	
15-6	S04897000	2	メクラセン	BLIND CAP	
16	S08178000	3	ブランチUY-4	BRANCH UY-4	
17	018503036	2	アナホルト5X30	BOLT 5X30	
18	028050246	2	ハ"ネサ"ガ"ネ2-5	SPRING WASHER 2-5	
22	S08163000	3	エアホース4-B	AIR TUBE 4-B (L=1280)	
23	S08164000	2	エアホース4-C	AIR TUBE 4-C (L=870)	
24	S08165000	1	エアホース4-D	AIR TUBE 4-D (L=1300)	
25	S08166000	1	エアホース4-E	AIR TUBE 4-E (L=1110)	
26	S08167000	3	エアホース4-F	AIR TUBE 4-F (L=1110)	
27	S08168000	1	エアホース4-G	AIR TUBE 4-G (L=1310)	
28	S08169000	2	エアホース4-H	AIR TUBE 4-H (L=1230)	
29	S08171000	4	エアホース4-J	AIR TUBE 4-J (L=1600)	
30	S08172000	2	エアホース4-K	AIR TUBE 4-K (L=1630)	
31	S08173000	4	エアホース4-L	AIR TUBE 4-L (L=1600)	
32	S08174000	2	エアホース4-M	AIR TUBE 4-M (L=130)	
34	S08176000	1	エアホース4-O	AIR TUBE 4-O (L=980)	
35	S08177000	1	エアホース4-P	AIR TUBE 4-P (L=1070)	
36	S04557000	17	ハ"ンタイPLTIM	BAND PLTIM	
37	149809000	2	タイラツプ"ル	BEAD BAND (L)	
38	554482000	1	コード"ホルタ" 12N	CORD HOLDER (12N)	
39	S00470000	1	コード"ホルタ" 16N	CORD HOLDER (16N)	
40	552907000	1	コード"ホルタ" 10N	CORD HOLDER (10N)	
41	062401006	3	ナヘ"コ4X10	SCREW 4X10	
42	025040233	3	ヒラサ"ガ"ネチユウ4	PLAIN WASHER 4	
43	S09141000	1	コード"クランプ"16L	CORD CLAMP 16-L	
44	S10557000	2	シホ"リノス"ル	THROTTLE NOZZLE	
			<605ヨウ>	<FOR 605>	
12	S08136000	1	イケイユニオン8-6	UNION 8-6	
			<フラップ"ツケヨウ/606>	<FOR FLAP / 606>	
11	S08145000	1	ユニオンY8-6	UNION Y 8-6	
14	S08147000	1	エアホース6-B	AIR TUBE 6-B (L=50)	
19	S08159001	1	ハ"ルブ"ユニットFLP	VALVE UNIT (FOR FLAP)	
19-1	S08151000	1	マニホルト"S-2	MANIFOLD S-2	
19-2	S08155000	2	ハ"ルブ"VZ3140	VALVE VZ3140	
19-3	140682001	1	サイレンサン	SILENCER	
19-4	153274001	2	1/8トメセン	CAP 1/8	
19-5	S01542000	1	エルボ"ユニオン61	ELBOW UNION 61	
19-6	S04897000	2	メクラセン	BLIND CAP	
20	018503036	2	アナホルト5X30	BOLT 5X30	
21	028050246	2	ハ"ネサ"ガ"ネ2-5	SPRING WASHER 2-5	
33	S08175000	2	エアホース4-N	AIR TUBE 4-N (L=1690)	

Q. 電装品関係/Power supply equipment mechanism/Stromversorgung/
Mécanisme de l'équipement en alimentation électrique/Mecanismo del equipo de alimentación de corriente

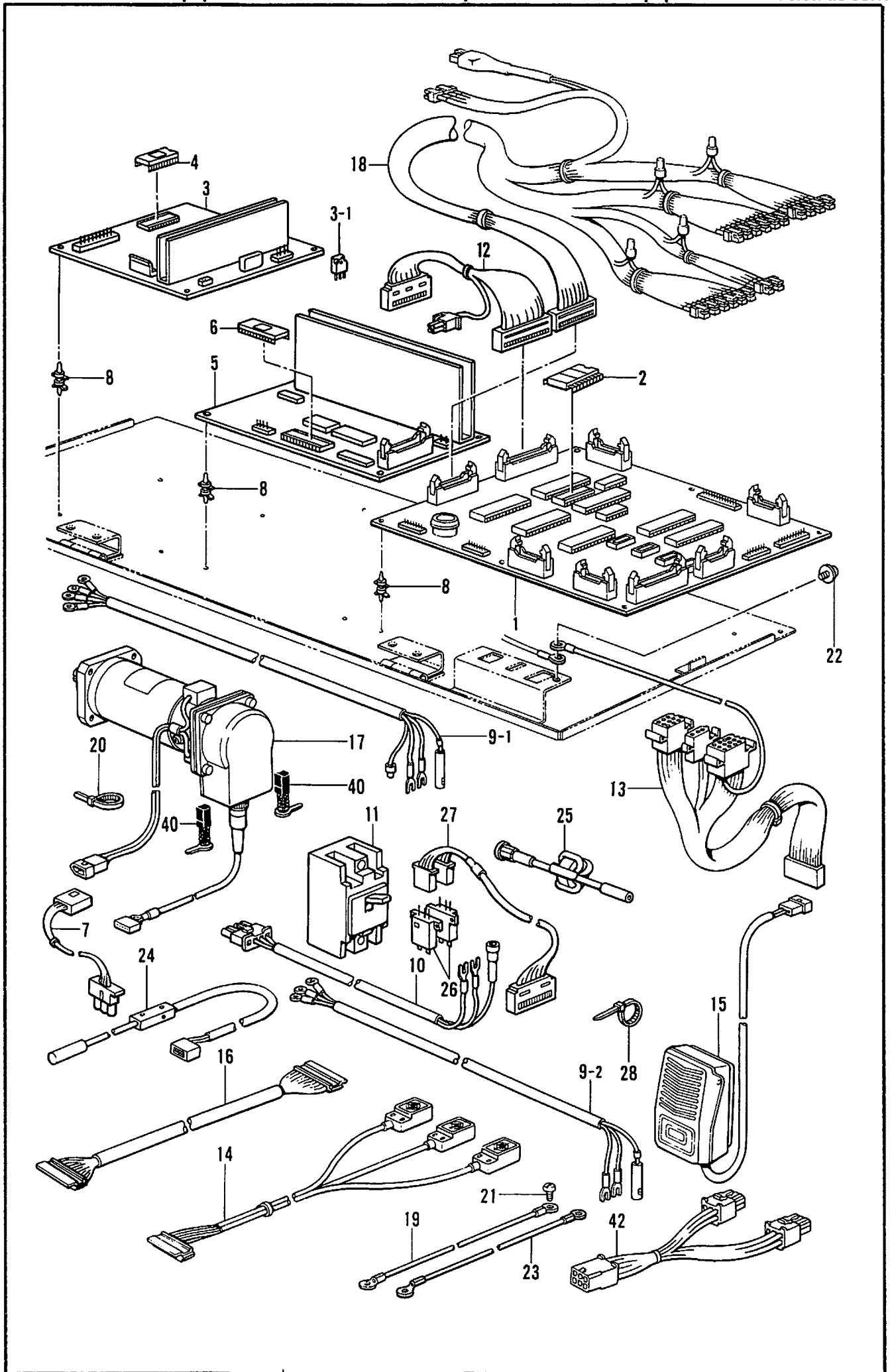

Q. 電装品関係/Power supply equipment mechanism/Stromversorgung/
 Mécanisme de l'équipement en alimentation électrique/Mecanismo del equipo de alimentación de corriente

REF.NO.	CODE	Q'TY	ヒンメイ	NAME OF PARTS	RMKS
1	S14412000	1	キハ"ンB439048クミ	CIRCUIT BOARD (B439048) ASSY	
2	S31884000	1	PROM605-1クミ	PROM 605-1 ASSY	
3	S29008001	1	モ-タキハ"ンクミ	MOTOR CIRCUIT BOARD ASSY	
3-1	S30206000	6	MOSFET2SK1936	MOSFET2SK1936	
4	S31889000	1	PROM605-2クミ	PROM 605-2 ASSY	
5	S31216000	1	キハ"ンB43K012クミ	CIRCUIT BOARD (B43K012) ASSY	
6	S31217000	1	PROM605-3クミ	PROM 605-3 ASSY	
7	S31215000	1	DCモ-タチユウケイハーネス	DC-MOTOR RELAY HARNESS	
8	S00554000	14	サポ-ト6NS	SUPPORT 6NS	
9-1	S08086000	1	POWハーネスAクミ	POWER HARNESS (A) ASSY	
10	S08105000	1	POWハーネスBクミ	POWER HARNESS (B) ASSY	
11	S21181000	1	ブ"レ-カーF5A	BREAKER (F5A)	
12	S31218000	1	M-DCハーネスクミ	M-DC HARNESS ASSY	
13	S08109000	1	PCBハーネス17Pクミ	PCB HARNESS 17P ASSY	
14	S08110000	1	キンセツスイッチクミ	PROXIMTY SWITCH ASSY	
15	S08114009	1	スタートSWクミ	START SWITCH ASSY	
16	S08115000	1	PCBハーネス15Pクミ	PCB HARNESS 15P ASSY	
17	S08116000	1	DCモ-タクミ	D.C.MOTOR ASSY	
18	S14414001	1	バルブ"ハーネスクミ	VALVE HARNESS ASSY	
19	S08113000	1	ア-スコ-ト"	EARTH WIRE	
20	S04557000	3	ハンタイPLTIM	BAND PLTIM	
21	062680616	1	ナヘ"コ437-40X6	SCREW 437X6	
22	052400806	1	ナヘ"コハ"ネヒラ4X8	WASHER SCREW 4X8	
23	S11337000	1	ア-スコ-ト"	EARTH WIRE	
24	S14118000	1	コーナメスセンサクミ	CORNER KNIFE SENSOR ASSY	
25	S31919000	1	ア-スインダ"クタ	EARTH INDUCTOR	
			<フラップ"ツケヨウ/606>	<FOR FLAP / 606>	
26	S31930000	2	フラツプ"センサ	FLAP SENSOR	
27	S31931000	1	フラツプ"センサハーネス	FLAP SENSOR HARNESS	
28	S04557000	3	ハンタイPLTIM	BAND PLTIM	
				<OPTION PARTS / FOR 1-PHASE>	
9-2	S16198000	1	-----	POWER HARNESS (A) ASSY	
			<ホキユウヨウ>	<FOR SUPPLY>	
40	S11338000	1	DCモ-タブ"ラシクミ	D.C. MOTOR BRUSH ASSY	
42	S18942000	1	マーキングライトハーネス	MARKING LIGHT HARNESS	

R1. 布制御関係 / Cloth control system mechanism / Stoffführungsvorrichtung /
 Mécanisme de la système de contrôle du tissu / Mecanismo de la sistema de control de tela

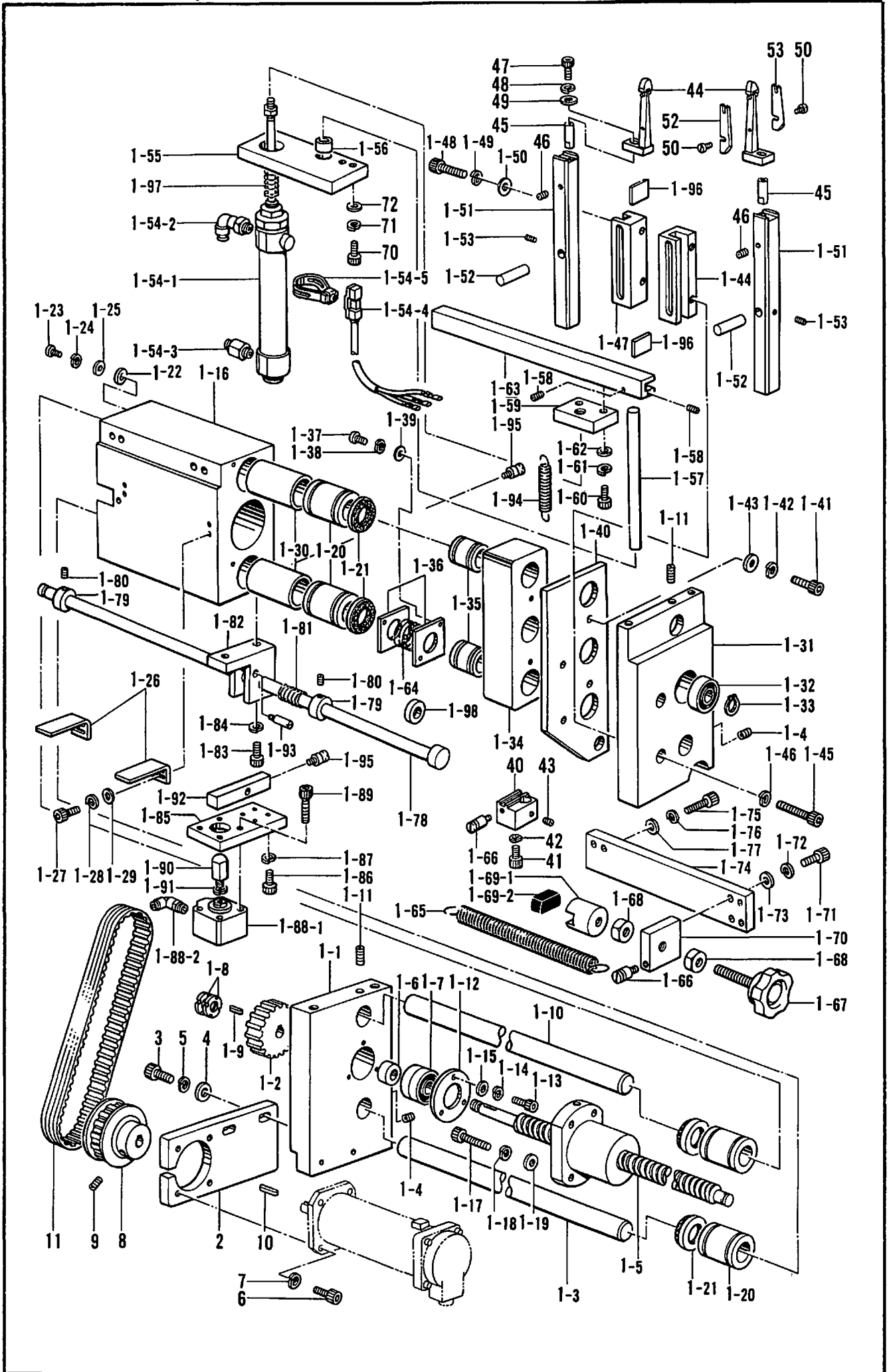

R1. 布制御関係/Cloth control system mechanism/Stoffführungsvorrichtung/
Mécanisme de la système de contrôle du tissu/Mecanismo de la sistema de control de tela

REF.NO.	CODE	Q'TY	ヒンメイ	NAME OF PARTS	RMKS
1	S32010001	1	オクリソウチクミ	FEED DEVICE ASSY	
1-1	S08284001	1	ボールネジ"サホ"ートL	BALL SCREW SUPPORT (L)	
1-2	S08286000	1	タイミング"プ"ーリア	TIMING PULLEY (A)	
1-3	S08289001	1	スライド"ジ"クシタ	SLIDE SHAFT LOWER	
1-4	014060622	2	アナトメネジ"6X6クホ"ミ	SET SCREW 6X6	
1-5	S08290001	1	ボールネジ"	BALL SCREW	
1-6	S08291001	1	カラー	COLLAR	
1-7	S08292000	1	タマシ"クウケ7201ADF	BALL BEARING 7201ADF	
1-8	073010002	2	ジ"クウケナツトAN01	BEARING NUT AN01	
1-9	S08280000	1	キー4X4X16	KEY 4X4X16	
1-10	S08293001	1	スライド"ジ"クウエ	SLIDE SHAFT UPPER	
1-11	014060622	2	アナトメネジ"6X6クホ"ミ	SET SCREW 6X6	
1-12	S08294001	1	へ"アリング"オサエ	BEARING PRESSER	
1-13	018401222	3	アナホ"ルト4X12	BOLT 4X12	
1-14	028040242	3	ハ"ネサ"カ"ネ2-4	SPRING WASHER 2-4	
1-15	025040232	3	ヒラサ"ガ"ネチユウ4	PLAIN WASHER 4	
1-16	S08295100	1	オオオサエイト"ウタ"イ	CARRIAGE FEED MOVABLE BASE	
1-17	018062522	4	アナホ"ルト6X25	BOLT 6X25	
1-18	028060242	4	ハ"ネサ"カ"ネ2-6	SPRING WASHER 2-6	
1-19	025060232	4	ヒラサ"ガ"ネチユウ6	PLAIN WASHER 6	
1-20	S09157000	4	リニアホ"ールへ"アリング"	LINEAR BALL BEARING	
1-21	S08400000	4	フェルトシール	FELT SEAL	
1-22	025040236	8	ヒラサ"ガ"ネチユウ4	PLAIN WASHER 4	
1-23	062300616	8	ナへ"コM3X6	SCREW M3X6	
1-24	028030243	8	ハ"ネサ"カ"ネ2-3	SPRING WASHER 2-3	
1-25	025030233	8	ヒラサ"ガ"ネチユウ3	PLAIN WASHER 3	
1-26	S08301001	2	センサーカンチイタ	SENSOR PERCEIVE PLATE	
1-27	018300822	4	アナホ"ルト3X8	BOLT 3X8	
1-28	028030242	4	ハ"ネサ"カ"ネ2-3	SPRING WASHER 2-3	
1-29	025030232	4	ヒラサ"ガ"ネチユウ3	PLAIN WASHER 3	
1-30	S08304001	2	ス"ー"サ	SPACER	
1-31	S14799001	1	ボールネジ"サホ"ートR	BALL SCREW SUPPORT (R)	
1-32	S08306000	1	タマシ"クウケ6201ZZ	BALL BEARING 6201ZZ	
1-33	048120142	1	トメワジ"クヨウC12	STOP RING C12	
1-34	S21225000	1	コーナーメスイト"ウタ"イ	CORNER KNIFE MOVABLE BASE	
1-35	S21224000	2	リニアホ"ールへ"アリング"	LINEAR BALL BEARING LM20UU-35	
1-36	S08300001	2	へ"アリング"オサエ	BEARING PRESSER	
1-37	062300616	4	ナへ"コM3X6	SCREW M3X6	
1-38	028030243	4	ハ"ネサ"カ"ネ2-3	SPRING WASHER 2-3	
1-39	025030233	4	ヒラサ"ガ"ネチユウ3	PLAIN WASHER 3	
1-40	S21407001	1	コーナーメスタ"イ	CORNER KNIFE BASE	
1-41	018501622	2	アナホ"ルト5X16	BOLT 5X16	
1-42	028050242	2	ハ"ネサ"カ"ネ2-5	SPRING WASHER 2-5	
1-43	025050232	2	ヒラサ"ガ"ネチユウ-5	PLAIN WASHER 5	
1-44	S08317001	1	スライド"ガ"イト"R	SLIDE GUIDE (R)	
1-45	018503022	2	アナホ"ルト5X30	BOLT 5X30	
1-46	028050242	2	ハ"ネサ"カ"ネ2-5	SPRING WASHER 2-5	
1-47	S08318001	1	スライド"ガ"イト"L	SLIDE GUIDE (L)	
1-48	018502022	2	アナホ"ルト5X20	BOLT 5X20	
1-49	028050242	2	ハ"ネサ"カ"ネ2-5	SPRING WASHER 2-5	
1-50	025050232	2	ヒラサ"ガ"ネチユウ-5	PLAIN WASHER 5	
1-51	S14754001	2	スライタ"ー	SLIDER	
1-52	S08320001	2	オシアケ"ピン	PIN	
1-53	014400422	2	アナトメネジ"4X4クホ"ミ	SET SCREW 4X4	
1-54	S08323000	1	シリンタ"クミ	CYLINDER ASSY	
1-54-1	S08324000	1	シリンタ"20X75	CYLINDER 20X75	
1-54-2	S06866000	1	バルブ"	VALVE	
1-54-3	S04910000	1	ハーフユニオン	HALF UNION	
1-54-4	S08488000	1	シリンタ"ーセンサ	CYLINDER SENSOR	
1-54-5	S08501000	1	トリツクカナク"20	FITTING CLAMP 20	
1-55	S08325001	1	シリンタ"トリツクタ"イ	CYLINDER FITTING BASE	
1-56	S08326000	1	ト"ライハ"アリング"	BUSH BM0812FB	

R1. 布制御関係/Cloth control system mechanism/Stoffführungsvorrichtung/
 Mécanisme de la système de contrôle du tissu/Mecanismo de la sistema de control de tela

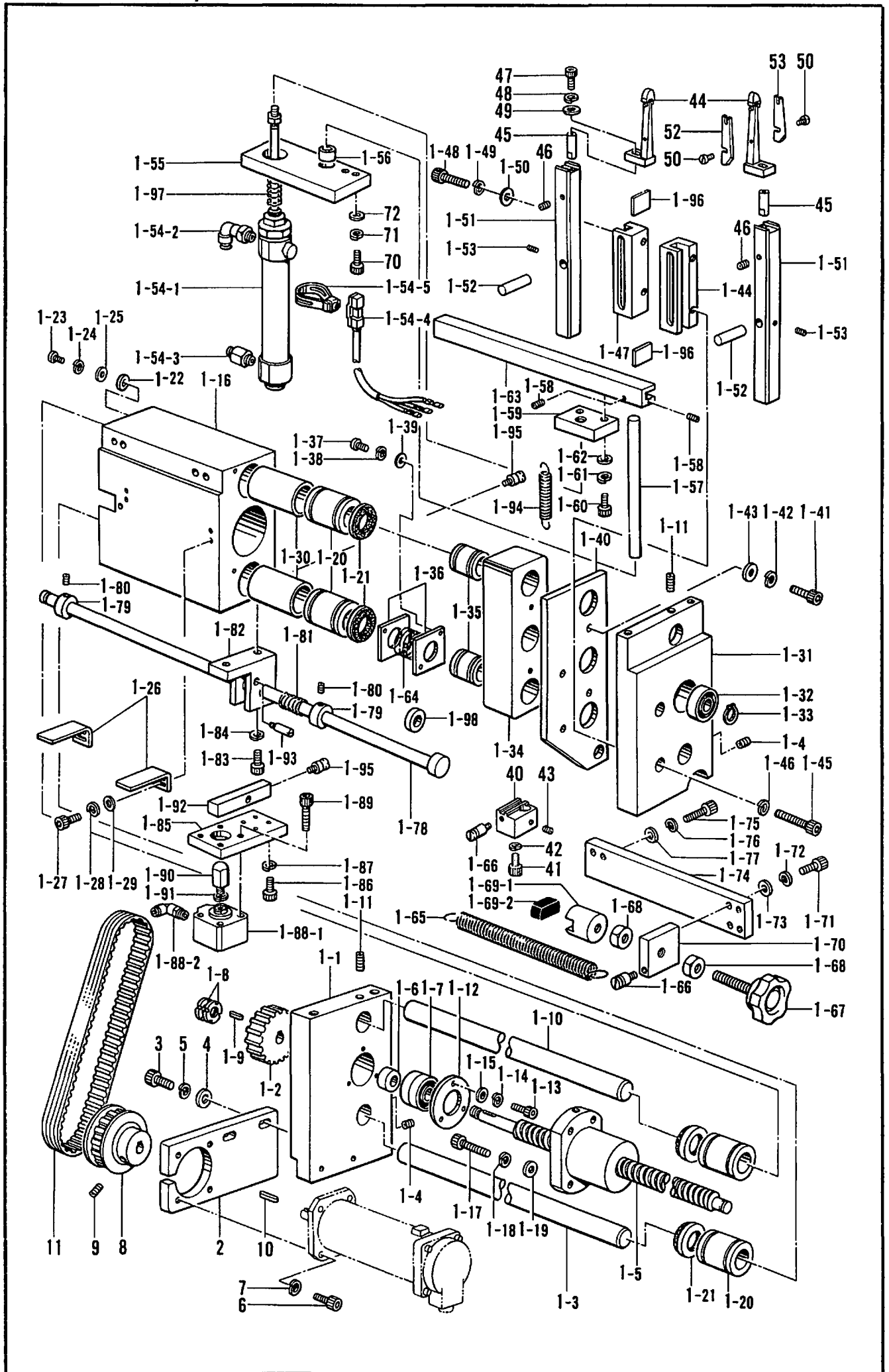

R1. 布制御関係 / Cloth control system mechanism / Stoffführungsrichtung /
 Mécanisme de la système de contrôle du tissu / Mecanismo de la sistema de control de tela

REF.NO.	CODE	Q'TY	ヒンメイ	NAME OF PARTS	RMKS
1-57	S08327001	1	マフリト"メシ"ク	BAFFLE WHIRL-STOP SHAFT	
1-58	014500522	2	アナトメネシ"5クホ"ミ	SET SCREW 5	
1-59	S08328001	1	シリンタ"レンケツイタ	CYLINDER CONNECTING PLATE	
1-60	018501622	2	アナホ"ルト5X16	BOLT 5X16	
1-61	028050242	2	ハ"ネサ"カ"ネ2-5	SPRING WASHER 2-5	
1-62	025050232	2	ヒラサ"カ"ネチユウ-5	PLAIN WASHER 5	
1-63	S08329001	1	コーナーメスオシアゲ"イタ	CORNER KNIFE LIFTING PLATE	
1-64	S08303001	1	アツシユクハ"ネ	SPRING	
1-65	S08308001	1	ヒツハ"リハ"ネ	SPRING	
1-66	S08509001	2	ハ"ネカケ	SPRING HOOK	
1-67	S08180000	1	ノブ"ホ"ルトM8X50	NOB BOLT M8X50	
1-68	021080206	2	2シユナツト8	NUT 8	
1-69	S09155000	1	マグ"ネットホルタ"ークミ	MAGNET HOLDER ASSY	
1-69-1	S09156000	1	マグ"ネットホルタ"	MAGNET HOLDER	
1-69-2	112525000	1	シユウシ"ンマグ"ネット	MAGNET	
1-70	S15201001	1	ハント"ルタ"イ	HANDLE BASE	
1-71	018061622	2	アナホ"ルト6X16	BOLT 6X16	
1-72	028060242	2	ハ"ネサ"カ"ネ2-6	SPRING WASHER 2-6	
1-73	025060232	2	ヒラサ"カ"ネチユウ6	PLAIN WASHER 6	
1-74	S09153001	1	チヨウセツタ"イ	ADJUST BASE	
1-75	018502022	2	アナホ"ルト5X20	BOLT 5X20	
1-76	028050242	2	ハ"ネサ"カ"ネ2-5	SPRING WASHER 2-5	
1-77	025050232	2	ヒラサ"カ"ネチユウ-5	PLAIN WASHER 5	
1-78	S08297001	1	イチキ"メロツト"	POSITIONING ROD	
1-79	S08296001	2	セツトカラー	SET COLLAR	
1-80	014500522	4	アナトメネシ"5クホ"ミ	SET SCREW 5	
1-81	148555001	1	シユレハ"ーモト"シハ"ネ	SPRING	
1-82	S15590001	1	クランプ"タ"イ	CLAMP BASE	
1-83	018501422	2	アナホ"ルト5X14	BOLT 5X14	
1-84	028050242	2	ハ"ネサ"カ"ネ2-5	SPRING WASHER 2-5	
1-85	S13638001	1	シリンタ"トリツケイタ	CYLINDER SET PLATE	
1-86	018401622	4	アナホ"ルト4X16	BOLT 4X16	
1-87	028040242	4	ハ"ネサ"カ"ネ2-4	SPRING WASHER 2-4	
1-88	S13639000	1	シリンタ"クミ	CYLINDER ASSY	
1-88-1	S13640000	1	シリンタ"32X10	CYLINDER (32X10)	
1-88-2	S06886000	1	ツキ"テ1/8-4	JOINT 1/8-4	
1-89	018062022	4	アナホ"ルト6X20	BOLT 6X20	
1-90	S13641001	1	プ"ツシヤ	PUSHER	
1-91	028060242	1	ハ"ネサ"カ"ネ2-6	SPRING WASHER 2-6	
1-92	S15591001	1	クランプ"レハ"ー	CLAMP LEVER	
1-93	S08315000	1	シテンシ"ク	FULCRUM SHAFT	
1-94	156292001	1	ストツハ"ーヒキハ"ネ	SPRING	
1-95	S08509001	2	ハ"ネカケ	SPRING HOOK	
1-96	S09170000	2	クツシヨシ"ンゴ"ム	CUSHION WASHER	
1-97	S09685101	1	アツシユクハ"ネ	SPRING	
1-98	S15202001	1	センサス"ヘ"ーサ	SENSOR SPACER	
2	S08285001	1	モ"ーターブ"ラケツト	MOTOR BRACKET	
3	018062522	2	アナホ"ルト6X25	BOLT 6X25	
4	025060232	2	ヒラサ"カ"ネチユウ6	PLAIN WASHER 6	
5	028060242	2	ハ"ネサ"カ"ネ2-6	SPRING WASHER 2-6	
6	018501622	4	アナホ"ルト5X16	BOLT 5X16	
7	028050242	4	ハ"ネサ"カ"ネ2-5	SPRING WASHER 2-5	
8	S08287000	1	タイミンク"プ"ーリB	TIMING PULLEY (B)	
9	014501222	2	アナトメネシ"5X12ヒラ	SET SCREW 5X12	
10	S10540000	1	キー"3X3X20	KEY 3X3X20	
11	S08288000	1	タイミンク"ヘ"ルト	TIMING BELT	
40	S15203000	1	センサブ"ラケツト	SENSOR BRACKET	
41	018402536	1	アナホ"ルト4X25	BOLT 4X25	
42	028040246	1	ハ"ネサ"カ"ネ2-4	SPRING WASHER 2-4	
43	012300336	1	アナヒラ3X3	SET SCREW 3X3	
44	*	2	メスタ"イクミ	KNIFE BASE ASSY	
45	S14753001	2	メスタ"イシ"ク	KNIFE BASE SHAFT	

R1. 布制御関係 / Cloth control system mechanism / Stoffführungsvorrichtung /
 Mécanisme de la système de contrôle du tissu / Mecanismo de la sistema de control de tela

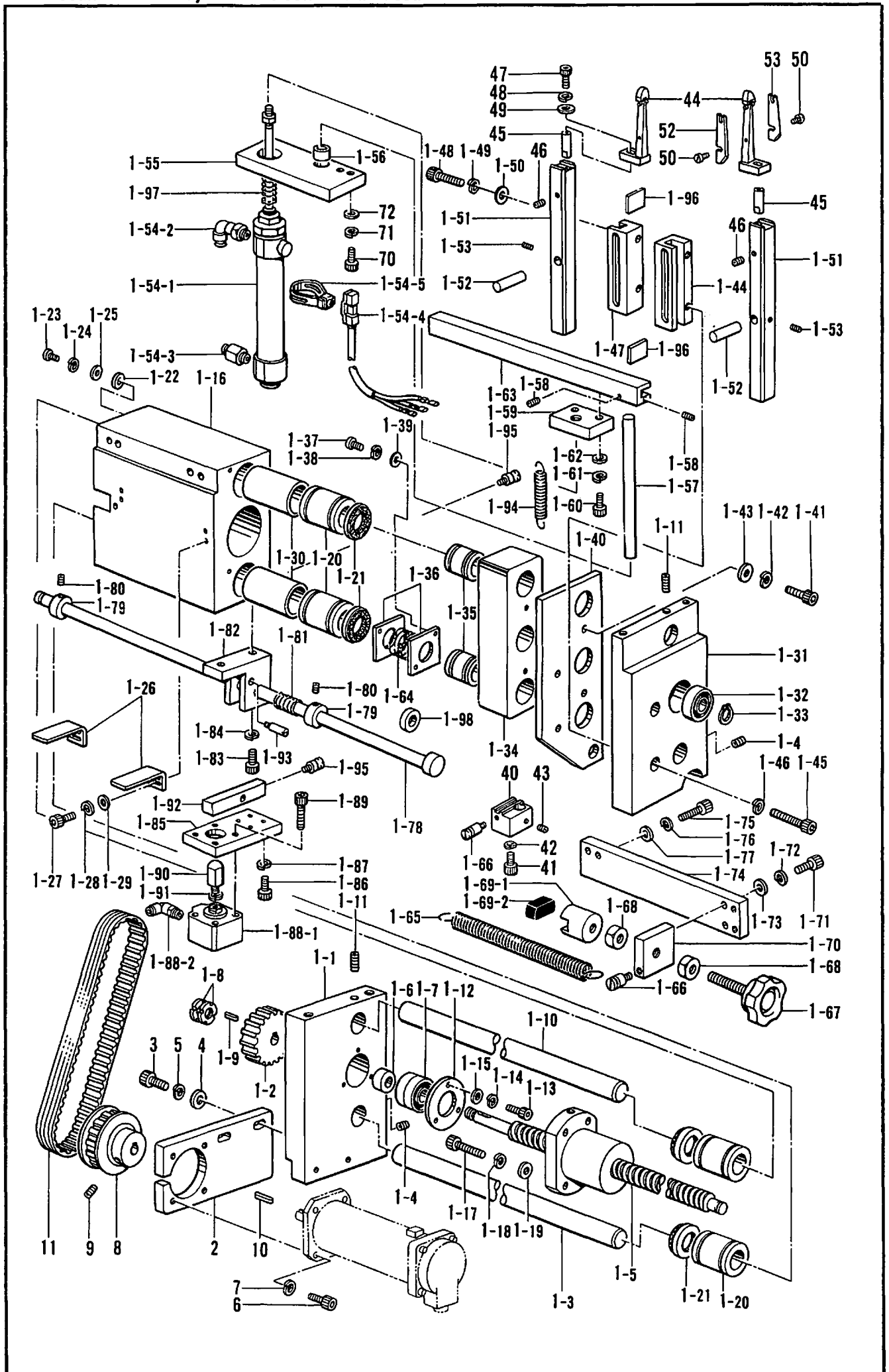

R1. 布制御関係/Cloth control system mechanism/Stoffführungsvorrichtung/
 Mécanisme de la système de contrôle du tissu/Mecanismo de la sistema de control de tela

REF.NO.	CODE	Q'TY	ヒンメイ	NAME OF PARTS	RMKS
46	012400436	2	アナヒラ4X4	SET SCREW 4X4	
47	018401236	2	アナボルト4X12	BOLT 4X12	
48	028040246	2	ハ"ネサ"ガ"ネ2-4	SPRING WASHER 2-4	
49	025040236	2	ヒラサ"ガ"ネチユウ4	PLAIN WASHER 4	
50	111140002	4	シメネジ"2.38	SCREW 2.38	
52	*	2	コーナーメス	CORNER KNIFE	
53	*	2	コーナーメス	CORNER KNIFE	
70	018062536	2	アナボルト6X25	BOLT 6X25	
71	028060246	2	ハ"ネサ"ガ"ネ2-6	SPRING WASHER 2-6	
72	025060236	2	ヒラサ"ガ"ネチユウ6	PLAIN WASHER 6	

R2. 布制御関係/Cloth control system mechanism/Stoffführungsvorrichtung/
Mécanisme de la système de contrôle du tissu/Mecanismo de la sistema de control de tela

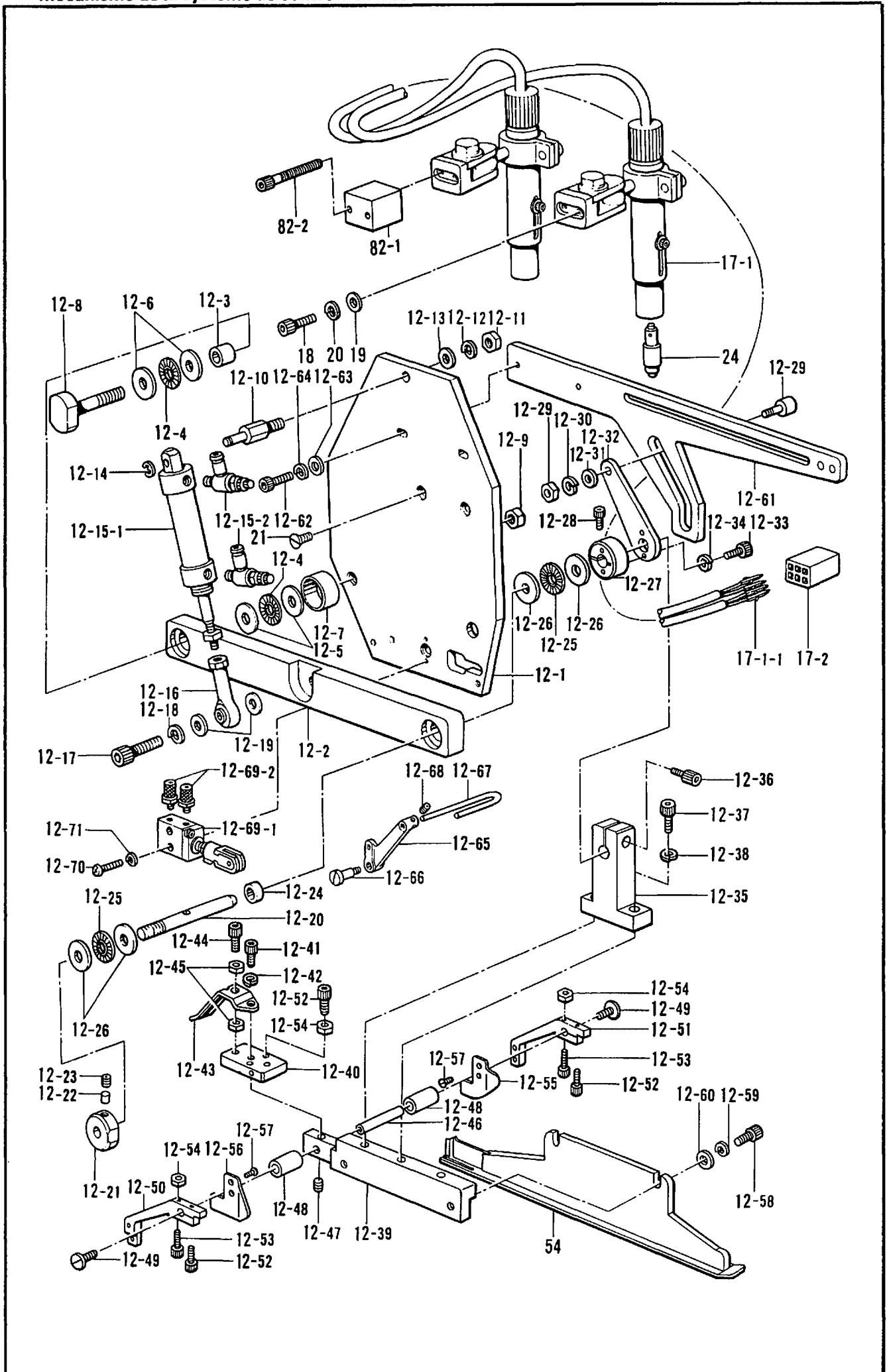

R2. 布制御関係/Cloth control system mechanism/Stoffführungsvorrichtung/
 Mécanisme de la système de contrôle du tissu/Mecanismo de la sistema de control de tela

REF.NO.	CODE	Q'TY	ヒンメイ	NAME OF PARTS	RMKS
12	S32011001	1	メンイタユニットクミ	FACE PLATE UNIT ASSY	
12-1	S15815001	1	メンイタ	FACE PLATE	
12-2	S31918001	1	アーム	ARM	
12-3	S08332000	1	ト"ライヘ"アリンク"	BUSH BM1212FB	
12-4	S08238000	2	スラストヘ"アリンク"	THRUST BEARING	
12-5	S08239000	2	スラストワッシヤ	THRUST WASHER	
12-6	S08240000	2	スラストワッシヤ	THRUST WASHER	
12-7	S08342001	1	スラストヘ"アリンク"カハ-	THRUST BEARING COVER	
12-8	S08333001	1	シデンジク	FULCRUM SHAFT	
12-9	021120304	1	ナツト3シユ12	NUT 12	
12-10	S08360001	1	シリンダ"トリツケジク	CYLINDER FITTING SHAFT	
12-11	021080206	1	2シユナツト8	NUT 8	
12-12	028080246	1	ハ"ネサ"カ"ネ2-8	SPRING WASHER 2-8	
12-13	025080236	1	ヒラサ"カ"ネチユウ8	PLAIN WASHER 8	
12-14	048040342	1	トメワE4	STOP RING E4	
12-15	S08335000	1	シリンダ"クミ	CYLINDER ASSY	
12-15-1	S08336000	1	シリンダ"20X35	CYLINDER 20X35	
12-15-2	S06898000	2	スピ"コンツキ"デ1/8-4	SPEED CONTROLLER JOINT 1/8-4	
12-16	S08352000	1	ロツト"エント"	ROD END	
12-17	018082536	1	アナホ"ルト8X25	BOLT 8X25	
12-18	028080246	1	ハ"ネサ"カ"ネ2-8	SPRING WASHER 2-8	
12-19	025080236	2	ヒラサ"カ"ネチユウ8	PLAIN WASHER 8	
12-20	S08341009	1	シ"ヨウキ"シデンジク	BINDER FULCRUM SHAFT	
12-21	S08338001	1	ヨアツナツト	PRE-LOAD NUT	
12-22	S08339001	1	ユルミト"メ	LOOSENESS STOPPER	
12-23	012060636	1	アナヒラ6X6	SET SCREW 6X6	
12-24	S31921000	1	ト"ライヘ"アリンク"	BUSH BM1208FB	
12-25	S08238000	2	スラストヘ"アリンク"	THRUST BEARING	
12-26	S08240000	4	スラストワッシヤ	THRUST WASHER	
12-27	S31927001	1	セツトカラー	SET COLLAR	
12-28	018401236	1	アナホ"ルト4X12	BOLT 4X12	
12-29	S08343000	1	カムフオロフ	CAM FOLLOWER	
12-30	028050246	1	ハ"ネサ"カ"ネ2-5	SPRING WASHER 2-5	
12-31	025050236	1	ヒラサ"カ"ネチユウ-5	PLAIN WASHER 5	
12-32	S31928001	1	カムフオロアトリツケイタ	CAM FOLLOWER SET BAR	
12-33	018501436	2	アナホ"ルト5X14	BOLT 5X14	
12-34	028050246	2	ハ"ネサ"カ"ネ2-5	SPRING WASHER 2-5	
12-35	S31926001	1	シ"ヨウキ"トリツケイタ	BINDER FITTING PLATE	
12-36	018062036	1	アナホ"ルト6X20	BOLT 6X20	
12-37	018501636	2	アナホ"ルト5X16	BOLT 5X16	
12-38	028050246	2	ハ"ネサ"カ"ネ2-5	SPRING WASHER 2-5	
12-39	S08347009	1	シ"ヨウキ"トリツケイタC	BINDER FITTING PLATE (C)	
12-40	S21006001	1	イタハ"ネタ"IF	PLATE SPRING BASE (F)	
12-41	018301236	2	アナホ"ルト3X12	BOLT 3X12	
12-42	028030246	2	ハ"ネサ"カ"ネ2-3	SPRING WASHER 2-3	
12-43	S31617001	1	イタハ"ネ	PLATE SPRING	
12-44	018301236	1	アナホ"ルト3X12	BOLT 3X12	
12-45	021300303	2	ナツト3シユ3	NUT 3	
12-46	S21008001	1	キジ"カ"イト"シデンシク	CLOTH GUIDE FULCRUM SHAFT	
12-47	012400436	1	アナヒラ4X4	SET SCREW 4X4	
12-48	S21009001	2	キジ"カ"イト"ヨウスリーブ"	SLEEVE FOR CLOTH GUIDE	
12-49	S30014001	2	フタネシ"M3	SCREW M3	
12-50	S31618001	1	キジ"カ"イト"アームL	CLOTH GUIDE ARM (L)	
12-51	S31948001	1	キジ"カ"イト"アームR	CLOTH GUIDE ARM (R)	
12-52	018301236	4	アナホ"ルト3X12	BOLT 3X12	
12-53	018301636	2	アナホ"ルト3X16	BOLT 3X16	
12-54	021300303	4	ナツト3シユ3	NUT 3	
12-55	S31619000	1	キジ"カ"イト"R	CLOTH GUIDE (R)	
12-56	S31620000	1	キジ"カ"イト"L	CLOTH GUIDE (L)	
12-57	061020506	4	サラゴ2X5	SCREW 2X5	
12-58	018501236	2	アナホ"ルト5X12	BOLT 5X12	
12-59	028050246	2	ハ"ネサ"カ"ネ2-5	SPRING WASHER 2-5	

R2. 布制御関係/Cloth control system mechanism/Stoffführungsvorrichtung/
 Mécanisme de la système de contrôle du tissu/Mecanismo de la sistema de control de tela

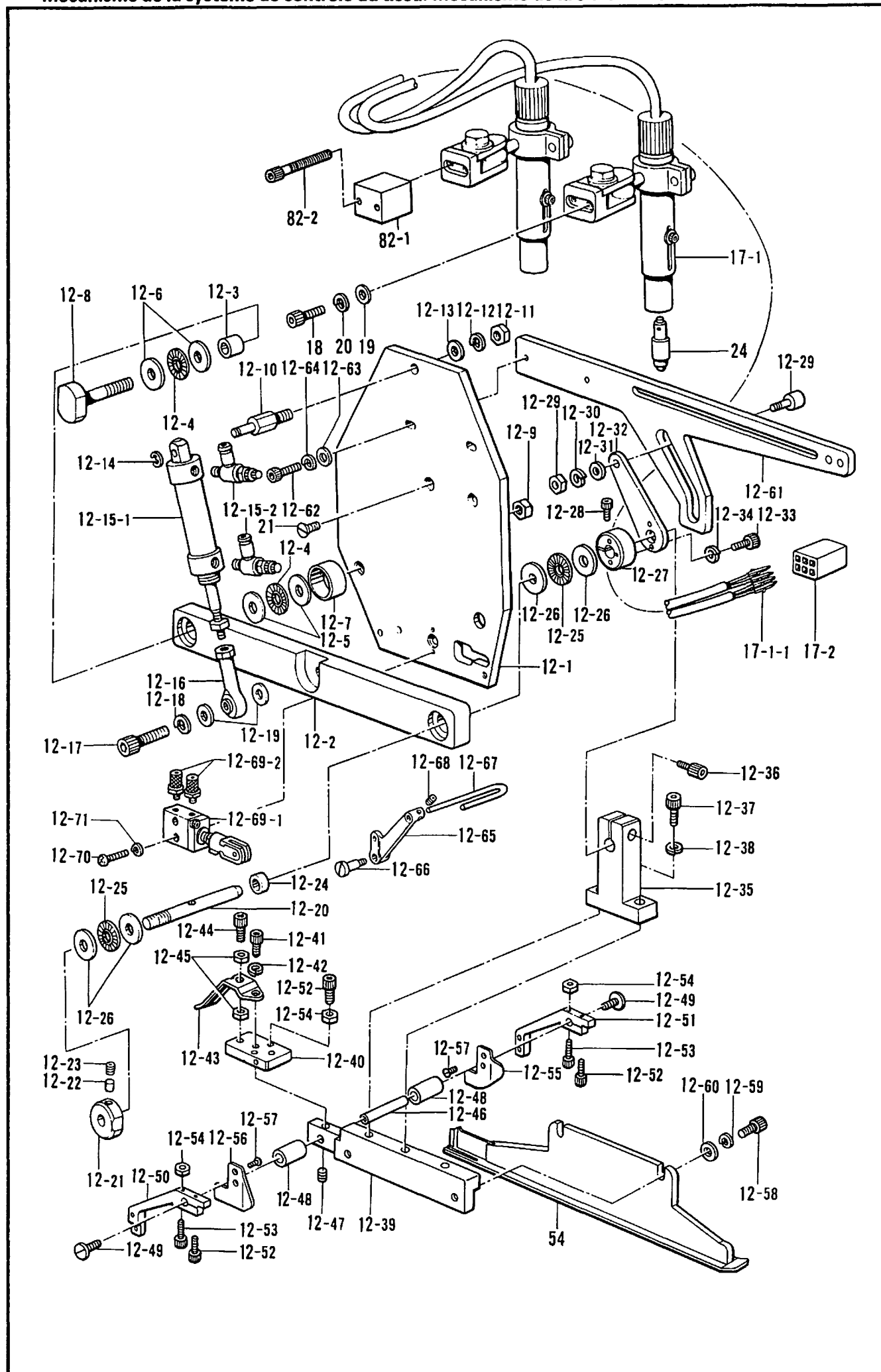

R2. 布制御関係/Cloth control system mechanism/StoffführungsVorrichtung/
 Mécanisme de la système de contrôle du tissu/Mecanismo de la sistema de control de tela

REF.NO.	CODE	Q'TY	ヒンメイ	NAME OF PARTS	RMKS
12-60	146354001	2	サ"ガ"ネ	WASHER	
12-61	S31929001	1	ミゾ"カムフ"レート	FLUTE CAM PLATE	
12-62	018501636	2	アナホ"ルト5X16	BOLT 5X16	
12-63	025050236	2	ヒラサ"ガ"ネチユウ-5	PLAIN WASHER 5	
12-64	028050246	2	ハ"ネサ"ガ"ネ2-5	SPRING WASHER 2-5	
12-65	S14703001	1	イトクリタ"シウテ"	THREAD TAKE-UP ARM	
12-66	141598001	1	ダン"ネジ"4.76	STUD SCREW 4.76	
12-67	S08372001	1	イトクリタ"シ	THREAD TAKE-UP	
12-68	012300336	2	アナヒラ3X3	SET SCREW 3X3	
12-69	S14704200	1	シリンダ"クミ	CYLINDER ASSY	
12-69-1	S14705000	1	シリンダ"10X5	CYLINDER 10X5	
12-69-2	S19900000	2	コテイシホ"リツキツキ"テ	THROTTLE TUBE JOINT	
12-70	062301605	2	ナヘ"ゴ3X16	SCREW 3X16	
12-71	028030243	2	ハ"ネサ"ガ"ネ2-3	SPRING WASHER 2-3	
17	S08502000	1	マーキング"ライトクミ	MARKING LIGHT ASSY	
17-1	S08367000	2	ライト"マーカ	MARKING LIGHT	
17-1-1	S08017000	2	オスピン"5006TL	PIN	
17-2	S08009000	1	コネクタ"5025-06P1	CONNECTOR (5025-06PI)	
18	018502036	2	アナホ"ルト5X20	BOLT 5X20	
19	025050236	4	ヒラサ"ガ"ネチユウ-5	PLAIN WASHER 5	
20	028050246	4	ハ"ネサ"ガ"ネ2-5	SPRING WASHER 2-5	
21	S01698001	3	サラネジ"5.95X12	SCREW 5.95X12	
24	S08137000	1	ランプ"5W	LAMP 5W	
54	*	1	ジ"ヨウキ"クミ	BINDER ASSY	
82	S30038001	1	ランプ"スヘ"ーサクミ	LAMP SPACER ASSY	
82-1	S29133000	1	ランプ"スヘ"ーサ	LAMP SPACER	
82-2	018504522	2	アナホ"ルト5X45	BOLT 5X45	
			<ホキユウヨウ>	<FOR SUPPLY>	
17	S18940000	1	マーキング"ライトクミE	MARKING LIGHT ASSY (E)	
17-1	S18894000	2	ライト"マーカE	MARKING LIGHT (E)	
17-1-1	S08017000	2	オスピン"5006TL	PIN	
17-2	S08009000	1	コネクタ"5025-06P1	CONNECTOR (5025-06PI)	
17	S18941000	1	マーキング"ライトクミL	MARKING LIGHT ASSY (L)	
17-1	S18895000	2	ライト"マーカL	MARKING LIGHT (L)	
17-1-1	S08017000	2	オスピン"5006TL	PIN	
17-2	S08009000	1	コネクタ"5025-06P1	CONNECTOR (5025-06PI)	

R3. 布制御関係/Cloth control system mechanism/Stoffführungsvorrichtung/
Mécanisme de la système de contrôle du tissu/Mecanismo de la sistema de control de tela

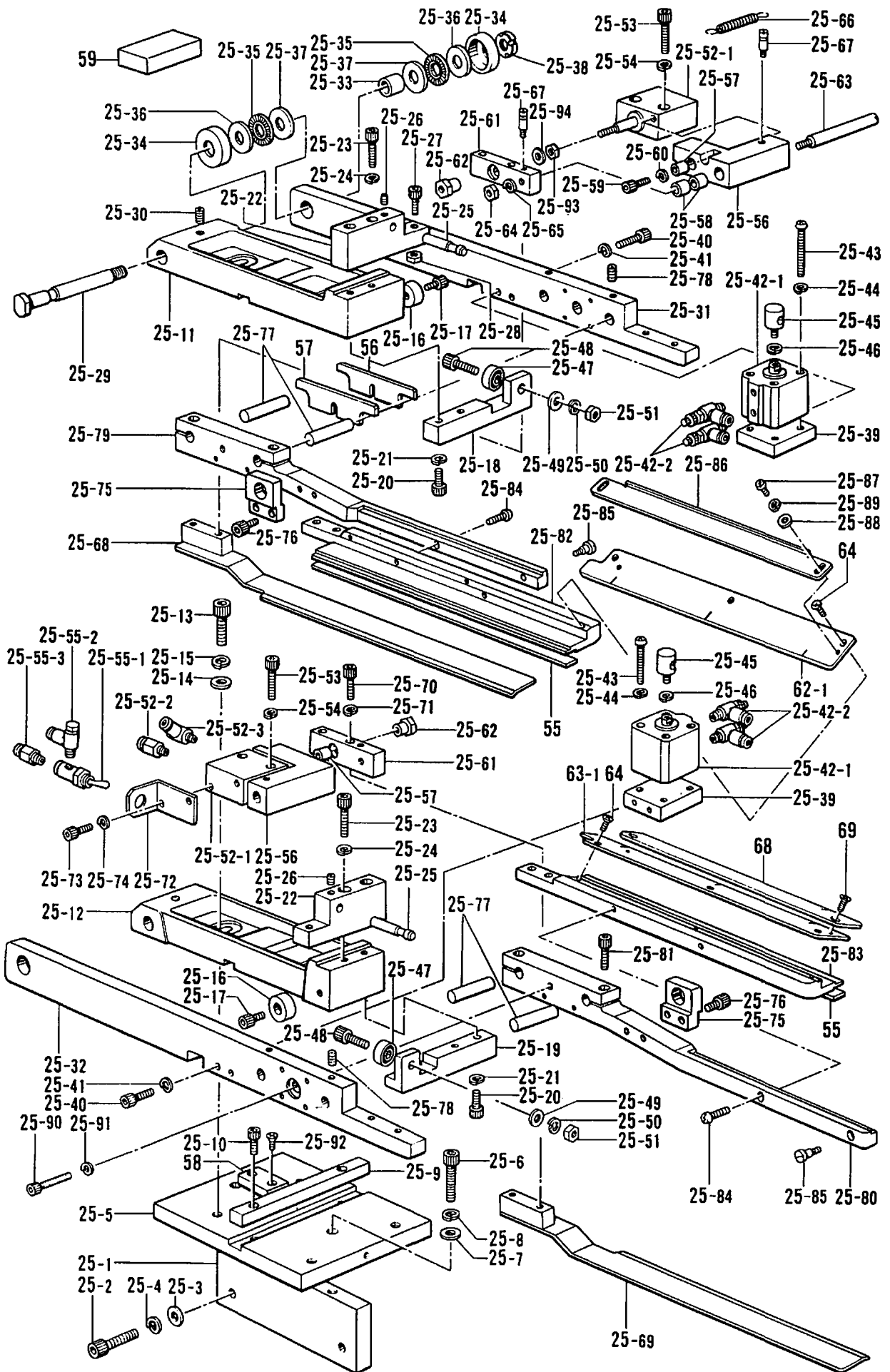

R3. 布制御関係/Cloth control system mechanism/StoffführungsVorrichtung/
 Mécanisme de la système de contrôle du tissu/Mecanismo de la sistema de control de tela

REF.NO.	CODE	Q'TY	ヒンメイ	NAME OF PARTS	RMKS
25	S31949001	1	オオオサイクミ	CARRIAGE FEED ASSY	
25-1	S08228001	1	オオオサエトリツケイタ	CARRIAGE FEED FITTING PLATE	
25-2	018083036	2	アナホ"ルト8X30	BOLT 8X30	
25-3	025080236	2	ヒラサ"カ"ネチユウ8	PLAIN WASHER 8	
25-4	028080246	2	ハ"ネサ"カ"ネ2-8	SPRING WASHER 2-8	
25-5	S08229001	1	オオオサエトリツケタ"イ	CARRIAGE FEED FITTING BASE	
25-6	018083036	2	アナホ"ルト8X30	BOLT 8X30	
25-7	025080236	2	ヒラサ"カ"ネチユウ8	PLAIN WASHER 8	
25-8	028080246	2	ハ"ネサ"カ"ネ2-8	SPRING WASHER 2-8	
25-9	S08230001	1	スライ"カ"イト"	SLIDE GUIDE	
25-10	018401036	2	アナホ"ルト4X10	BOLT 4X10	
25-11	S08231000	1	オオオサエイト"ウタ"イR	CARRIAGE FEED MOVABLE BASE (R)	
25-12	S08232000	1	オオオサエイト"ウタ"イL	CARRIAGE FEED MOVABLE BASE (L)	
25-13	018082536	4	アナホ"ルト8X25	BOLT 8X25	
25-14	025080236	4	ヒラサ"カ"ネチユウ8	PLAIN WASHER 8	
25-15	028080246	4	ハ"ネサ"カ"ネ2-8	SPRING WASHER 2-8	
25-16	S08233000	2	ス"リ"カ"イト"	SLIDE GUIDE	
25-17	018501036	2	アナホ"ルト5X10	BOLT 5X10	
25-18	S08245001	1	ガ"イト"ローラ"イR	GUIDE ROLLER BASE (R)	
25-19	S08246001	1	ガ"イト"ローラ"イL	GUIDE ROLLER BASE (L)	
25-20	018501436	4	アナホ"ルト5X14	BOLT 5X14	
25-21	028050246	4	ハ"ネサ"カ"ネ2-5	SPRING WASHER 2-5	
25-22	S08248001	2	レンケツシ"クササエ	CONNECTING SHAFT SUPPORT	
25-23	018502536	4	アナホ"ルト5X25	BOLT 5X25	
25-24	028050246	4	ハ"ネサ"カ"ネ2-5	SPRING WASHER 2-5	
25-25	S08247001	2	オサエロツト"	PRESSER ROD	
25-26	012500536	2	アナヒラ5X5	SET SCREW 5X5	
25-27	018502036	2	アナホ"ルト5X20	BOLT 5X20	
25-28	021500103	2	ナツト1シユ5	NUT 5	
25-29	S08234001	2	シデンシ"ク	FULCRUM SHAFT	
25-30	012500536	2	アナヒラ5X5	SET SCREW 5X5	
25-31	S31233001	1	オオオサエウテ"R	CARRIAGE FEED ARM (R)	
25-32	S31237001	1	オオオサエウテ"L	CARRIAGE FEED ARM (L)	
25-33	S08332000	2	ト"ライハ"アリング"	BUSH BM1212FB	
25-34	S08237001	4	スラストハ"アリング"カハ"	THRUST BEARING COVER	
25-35	S08238000	4	スラストハ"アリング"	THRUST BEARING	
25-36	S08239000	4	スラストワツシヤ	THRUST WASHER	
25-37	S08240000	4	スラストワツシヤ	THRUST WASHER	
25-38	S16887001	2	フアイ"U"ナツトAN01	NUT AN01	
25-39	S08241001	2	シリンダ"ーウケ	CYLINDER SUPPOTER	
25-40	018502036	4	アナホ"ルト5X20	BOLT 5X20	
25-41	028050246	4	ハ"ネサ"カ"ネ2-5	SPRING WASHER 2-5	
25-42	S08242000	2	シリンダ"クミ	CYLINDER ASSY	
25-42-1	S08252000	2	シリンダ"20X15	CYLINDER 20X15	
25-42-2	S08498000	4	スピコンツキ"テム5-4	SPEED CONTROLLER JOINT M5-4	
25-43	062304006	8	ナハ"コ3X40	SCREW 3X40	
25-44	028030243	8	ハ"ネサ"カ"ネ2-3	SPRING WASHER 2-3	
25-45	S08142001	2	レンケツシ"ク	CONNECTING SHAFT	
25-46	028040243	2	ハ"ネサ"カ"ネ2-4	SPRING WASHER 2-4	
25-47	S08249000	2	ハ"アリング"MR626ZZ	BEARING MR626ZZ	
25-48	018062036	2	アナホ"ルト6X20	BOLT 6X20	
25-49	025060236	2	ヒラサ"カ"ネチユウ6	PLAIN WASHER 6	
25-50	028060246	2	ハ"ネサ"カ"ネ2-6	SPRING WASHER 2-6	
25-51	021060206	2	2シユナツト6	NUT 6	
25-52	S08250000	2	シリンダ"クミ	CYLINDER ASSY	
25-52-1	S08251000	2	シリンダ"16X20	CYLINDER 16X20	
25-52-2	S06882000	2	ツキ"テム5-4	JOINT M5-4	
25-52-3	S06883000	2	Sエルホ"M5-4	S-ELBOW M5-4	
25-53	018402536	4	アナホ"ルト4X25	BOLT 4X25	
25-54	028040246	4	ハ"ネサ"カ"ネ2-4	SPRING WASHER 2-4	

R3. 布制御関係 / Cloth control system mechanism / Stoffführungsvorrichtung /
 Mécanisme de la système de contrôle du tissu / Mecanismo de la sistema de control de tela

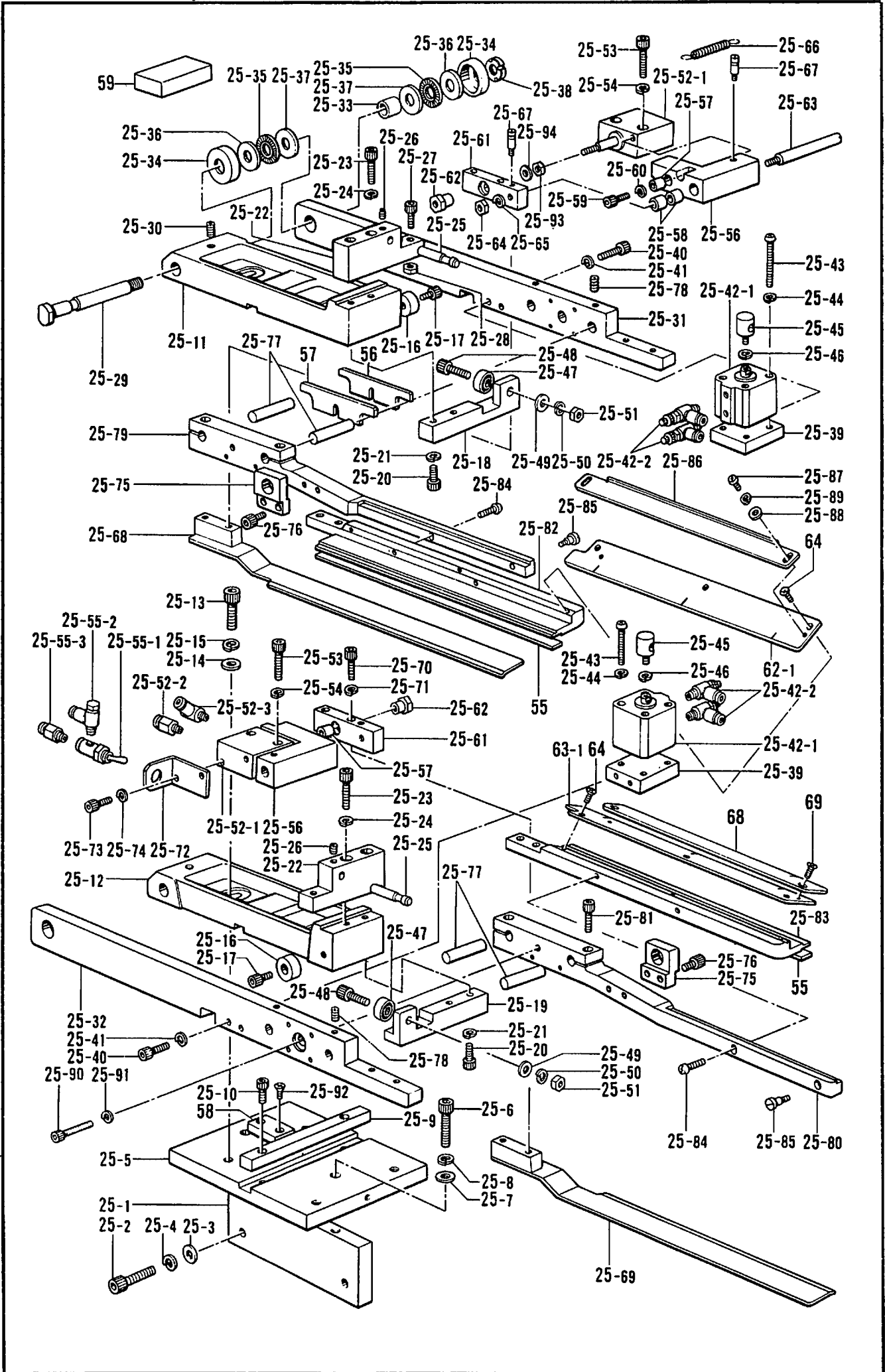

R3. 布制御関係/Cloth control system mechanism/StoffführungsVorrichtung/
 Mécanisme de la système de contrôle du tissu/Mecanismo de la sistema de control de tela

REF.NO.	CODE	Q'TY	ヒンメイ	NAME OF PARTS	RMKS
25-55	S08493000	2	キリカエハ"ルフ"クミ	SELECTOR VALVE ASSY	
25-55-1	S08489000	2	シユト"ウハ"ルフ"	HAND VALVE	
25-55-2	S06883000	2	Sエルボ"M5-4	S-ELBOW M5-4	
25-55-3	S06882000	2	ツキ"テM5-4	JOINT M5-4	
25-56	S08253000	2	ガ"イト"シ"クフ"ラケット	GUIDE SHAFT BRACKET	
25-57	S08507000	2	ト"ライヘ"アリング"	BUSH BM0608FB	
25-58	S08326000	4	ト"ライヘ"アリング"	BUSH BM0812FB	
25-59	018401236	4	アナホ"ルト4X12	BOLT 4X12	
25-60	028040246	4	ハ"ネサ"カ"ネ2-4	SPRING WASHER 2-4	
25-61	S08207001	2	シリンダ"ーレンゲツイタ	CYLINDER CONNECTING PLATE	
25-62	S08149001	2	ナツト	NUT	
25-63	S08256001	2	ガ"イト"シ"ク	GUIDE SHAFT	
25-64	021060206	2	2シユナツト6	NUT 6	
25-65	028060246	2	ハ"ネサ"カ"ネ2-6	SPRING WASHER 2-6	
25-66	S08216001	2	ヒツハリハ"ネ	SPRING	
25-67	S08509001	4	ハ"ネカク	SPRING HOOK	
25-68	S08254001	1	オリコミイタR	FOLDING PLATE (R)	
25-69	S08255001	1	オリコミイタL	FOLDING PLATE (L)	
25-70	018401636	4	アナホ"ルト4X16	BOLT 4X16	
25-71	028040246	4	ハ"ネサ"カ"ネ2-4	SPRING WASHER 2-4	
25-72	S08148001	2	ハ"ルフ"ササエ	VALVE SUPPORT	
25-73	018400836	4	アナホ"ルト4X8	BOLT 4X8	
25-74	028040246	4	ハ"ネサ"カ"ネ2-4	SPRING WASHER 2-4	
25-75	S31920001	2	オリコミイタストツハ"	FOLDING PLATE STOPPER	
25-76	018401036	4	アナホ"ルト4X10	BOLT 4X10	
25-77	S08257001	4	ガ"イト"シ"ク	GUIDE SHAFT	
25-78	012500536	4	アナヒラ5X5	SET SCREW 5X5	
25-79	S08258101	1	オオオサエトリツケイタR	CARRIAGE FEED FITTING PLATE (R)	
25-80	S08259101	1	オオオサエトリツケイタL	CARRIAGE FEED FITTING PLATE (L)	
25-81	018501636	4	アナホ"ルト5X16	BOLT 5X16	
25-82	S08260001	1	オオオサエR	CARRIAGE FEED (R)	
25-83	S08261001	1	オオオサエL	CARRIAGE FEED (L)	
25-84	062712012	2	ナヘ"コ476-32X20	SCREW 476X20	
25-85	110233001	2	ダ"ンネジ"4.76	STUD SCREW 4.76	
25-86	S08264001	2	キジ"ガ"イト"	CLOTH GUIDE	
25-87	062300416	4	ナヘ"コM3X4	SCREW M3X4	
25-88	025030233	4	ヒラサ"カ"ネチユウ3	PLAIN WASHER 3	
25-89	028030243	4	ハ"ネサ"カ"ネ2-3	SPRING WASHER 2-3	
25-90	S31991001	2	アナホ"ルト 5X40	BOLT 5X40	
25-91	028050242	2	ハ"ネサ"カ"ネ2-5	SPRING WASHER 2-5	
25-92	004401003	2	+サラコ4X10	SCREW 4X10	
25-93	S13084001	2	ナツト	NUT	
25-94	S24033001	2	サ"カ"ネ12.8	WASHER 12.8	
55	*	2	オオオサエゴ"ム	CORRIAGE FEED RUBBER	
56	*	2	スヘ"ーサS	SPACER (S)	
57	*	2	スヘ"ーサW	SPACER (W)	
58	*	1	イト"ウダ"イスヘ"ーサ	MOVABLE BASE SPACER	
59	*	1	オオオサエケ"ージ"	ADJUST GAUGE	
64	004300513	6	+サラコ3X5	SCREW 3X5	
68	*	1	オリコミイタオサエ	FOLDING PLATE PRESSER	
69	*	2	+サラコ3X5	SCREW 3X5	
			<605ヨウ>	<FOR 605>	
62-1	S31914001	1	オオオサエU-SR	CARRIAGE FEED (U-SR)	
63-1	S31915001	1	オオオサエU-SL	CARRIAGE FEED (U-SL)	

R4. 布制御関係 / Cloth control system mechanism / Stoffführungsvorrichtung /
 Mécanisme de la système de contrôle du tissu / Mecanismo de la sistema de control de tela

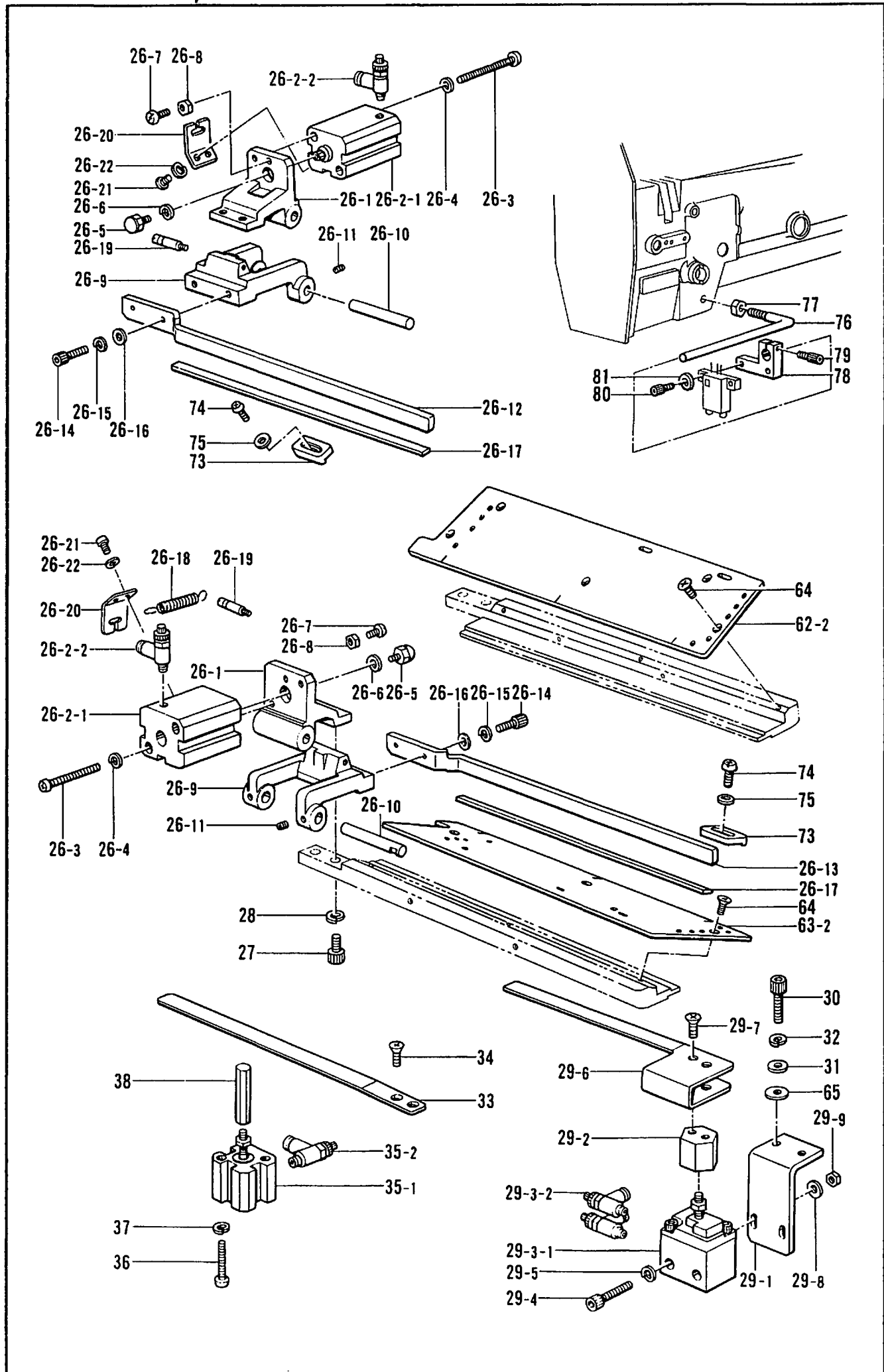

R4. 布制御関係/Cloth control system mechanism/StoffführungsVorrichtung/
 Mécanisme de la système de contrôle du tissu/Mecanismo de la sistema de control de tela

REF.NO.	CODE	Q'TY	ヒンメイ	NAME OF PARTS	RMKS
29	S09447009	1	シンシ"オサエクミ	FUSING PAPER PRESSER FOOT ASSY	
29-1	S08211001	1	シリンダ"トリツケイタ	CYLINDER FITTING PLATE	
29-2	S08213001	1	ハ"ネツケシ"ク	SPRING FITTING SHAFT	
29-3	S08499000	1	シリンダ"クミ	CYLINDER ASSY	
29-3-1	S08243000	1	シリンダ"16X10	CYLINDER 16X10	
29-3-2	S08498000	2	スピ"コンツキ"テム5-4	SPEED CONTROLLER JOINT M5-4	
29-4	018402536	2	アナホ"ルト4X25	BOLT 4X25	
29-5	028040246	4	ハ"ネサ"カ"ネ2-4	SPRING WASHER 2-4	
29-6	S08215009	1	シンシ"オサエハ"ネR	SPRING (R)	
29-7	004300513	2	+サラコ3X5	SCREW 3X5	
29-8	025040236	2	ヒラサ"カ"ネチユウ4	PLAIN WASHER 4	
29-9	021400202	2	2シユナツト4	NUT 4	
30	018501636	2	アナホ"ルト5X16	BOLT 5X16	
31	025050236	2	ヒラサ"カ"ネチユウ-5	PLAIN WASHER 5	
32	028050246	2	ハ"ネサ"カ"ネ2-5	SPRING WASHER 2-5	
33	S08214009	1	シシ"オサエハ"ネL	SPRING (L)	
34	004401003	2	+サラコ4X10	SCREW 4X10	
35	S09174000	1	シリンダ"クミ	CYLINDER ASSY	
35-1	S09175000	1	シリンダ"10X5	CYLINDER 10X5	
35-2	S06890000	1	スピ"コンツキ"テム5-4	SPEED CONTROLLER JOINT M5-4	
36	062302506	2	ナヘ"コ3X25	SCREW 3X25	
37	028030243	2	ハ"ネサ"カ"ネ2-3	SPRING WASHER 2-3	
38	S08208001	1	シンシ"フツシヤ	SHAFT	
65	025060336	2	ヒラサ"カ"ネタ"イ6	PLAIN WASHER 6	

R4. 布制御関係 / Cloth control system mechanism / Stoffführungsvorrichtung /
 Mécanisme de la système de contrôle du tissu / Mecanismo de la sistema de control de tela

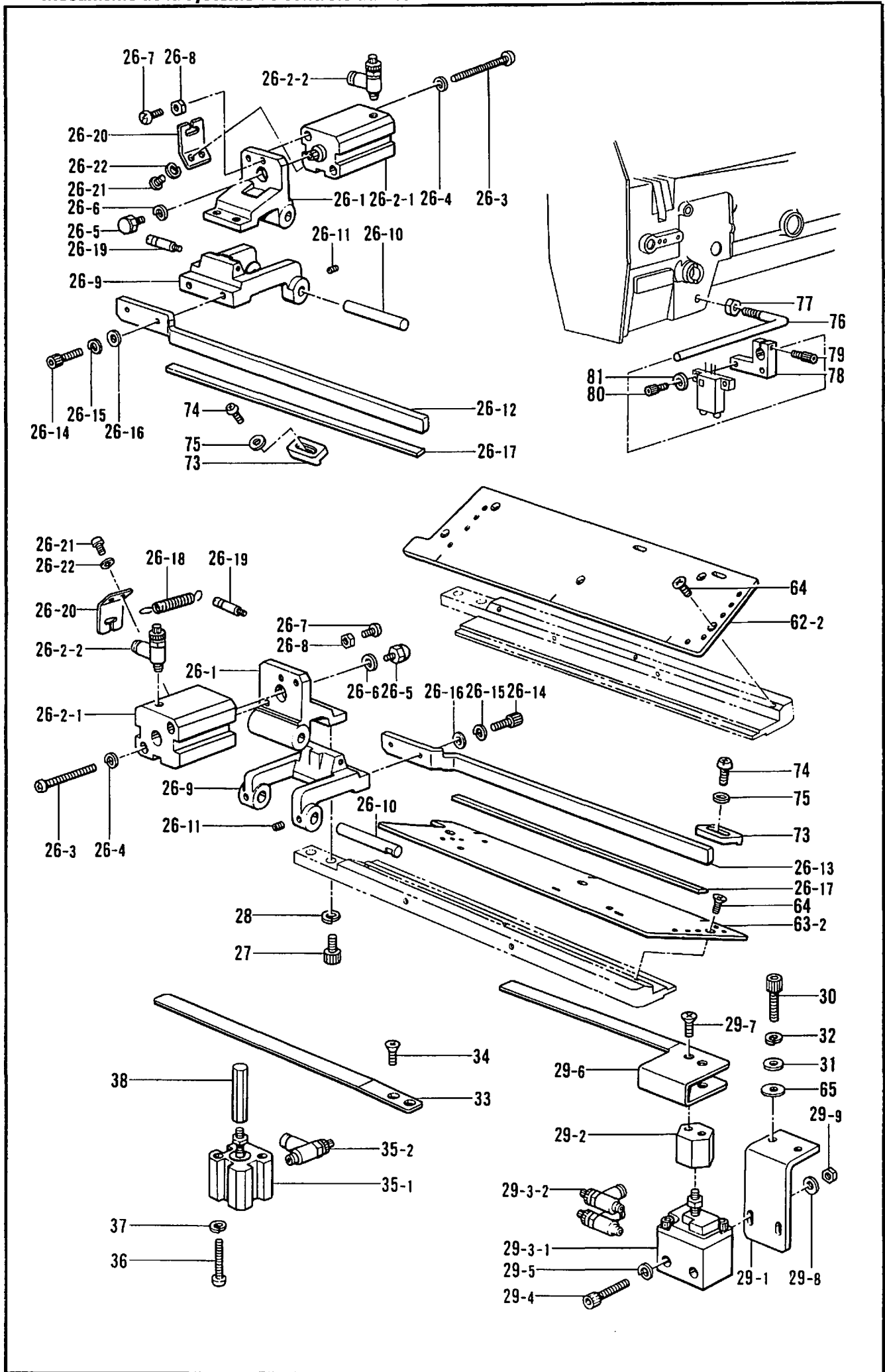

R4. 布制御関係/Cloth control system mechanism/Stoffführungsvorrichtung/
 Mécanisme de la système de contrôle du tissu/Mecanismo de la sistema de control de tela

REF.NO.	CODE	Q'TY	ヒンメイ	NAME OF PARTS	RMKS
			<フラップツケヨウ/606>	<FOR FLAP / 606>	
26	S32018001	1	フラップオサエクミ	FLAP PRESSER ASSY	
26-1	S08268001	2	レバータイ	LEVER BRACKET	
26-2	S08271000	2	シリンダクミ	CYLINDER ASSY	
26-2-1	S08272000	2	シリンダ16X20	CYLINDER 16X20	
26-2-2	S06890000	2	スピコンツキテム5-4	SPEED CONTROLLER JOINT M5-4	
26-3	S10551001	4	+ナヘネシ3X55	SCREW 3X55	
26-4	O28030243	4	ハネサカネ2-3	SPRING WASHER 2-3	
26-5	S08273001	2	プツシヤ	PUSHER	
26-6	O28030243	2	ハネサカネ2-3	SPRING WASHER 2-3	
26-7	O62400812	2	ナヘコ4X8	SCREW 4X8	
26-8	O21400202	2	2シユナツト4	NUT 4	
26-9	S08275001	2	フラップオサエレバー	FLAP PRESSER LEVER	
26-10	S08276001	2	シテンシク	FULCRUM SHAFT	
26-11	O14400522	4	アナホルト4X5	SET SCREW 4X5	
26-12	S31924001	1	フラップオサER	FLAP PRESSER (R)	
26-13	S31925001	1	フラップオサEL	FLAP PRESSER (L)	
26-14	O18401422	4	アナホルト4X14	BOLT 4X14	
26-15	O28040242	4	ハネサカネ2-4	SPRING WASHER 2-4	
26-16	O25040132	4	ヒラサカネシヨウ4	PLAIN WASHER 4	
26-17	S08279000	2	フラップオサエコム	FLAP PRESSER RUBBER	
26-18	S03557001	2	スライダヒキハネ	SPRING	
26-19	S08509001	2	ハネカケ	SPRING HOOK	
26-20	S09446001	2	ハネカケB	SPRING HOOK (B)	
26-21	O62300512	4	ナヘコ3X5	SCREW 3X5	
26-22	O28030243	4	ハネサカネ2-3	SPRING WASHER 2-3	
27	O18500836	4	アナホルト5X8	BOLT 5X8	
28	O28050246	4	ハネサカネ2-5	SPRING WASHER 2-5	
62-2	S31916001	1	オオオサIU-R	CARRIAGE FEED (U-R)	
63-2	S31917001	1	オオオサIU-L	CARRIAGE FEED (U-L)	
64	O04300513	6	+サラコ3X5	SCREW 3X5	
73	S08266001	2	フラップストツパ	FLAP STOPPER	
74	O62300416	2	ナヘコM3X4	SCREW M3X4	
75	O25030133	2	ヒラサカネシヨウ3	PLAIN WASHER 3	
76	S31923001	1	センサスライガイド	SENSOR SLIDE GUIDE	
77	O21500103	1	ナツト1シユ5	NUT 5	
78	S31922001	2	センサブラケット	SENSOR BRACKET	
79	O18300836	2	アナホルト3X8	BOLT 3X8	
80	O18300836	4	アナホルト3X8	BOLT 3X8	
81	O28030246	4	ハネサカネ2-3	SPRING WASHER 2-3	

S. 針位置検出器関係 / Synchronizer / Synchronisator /
Synchronisateur / Sincronizador

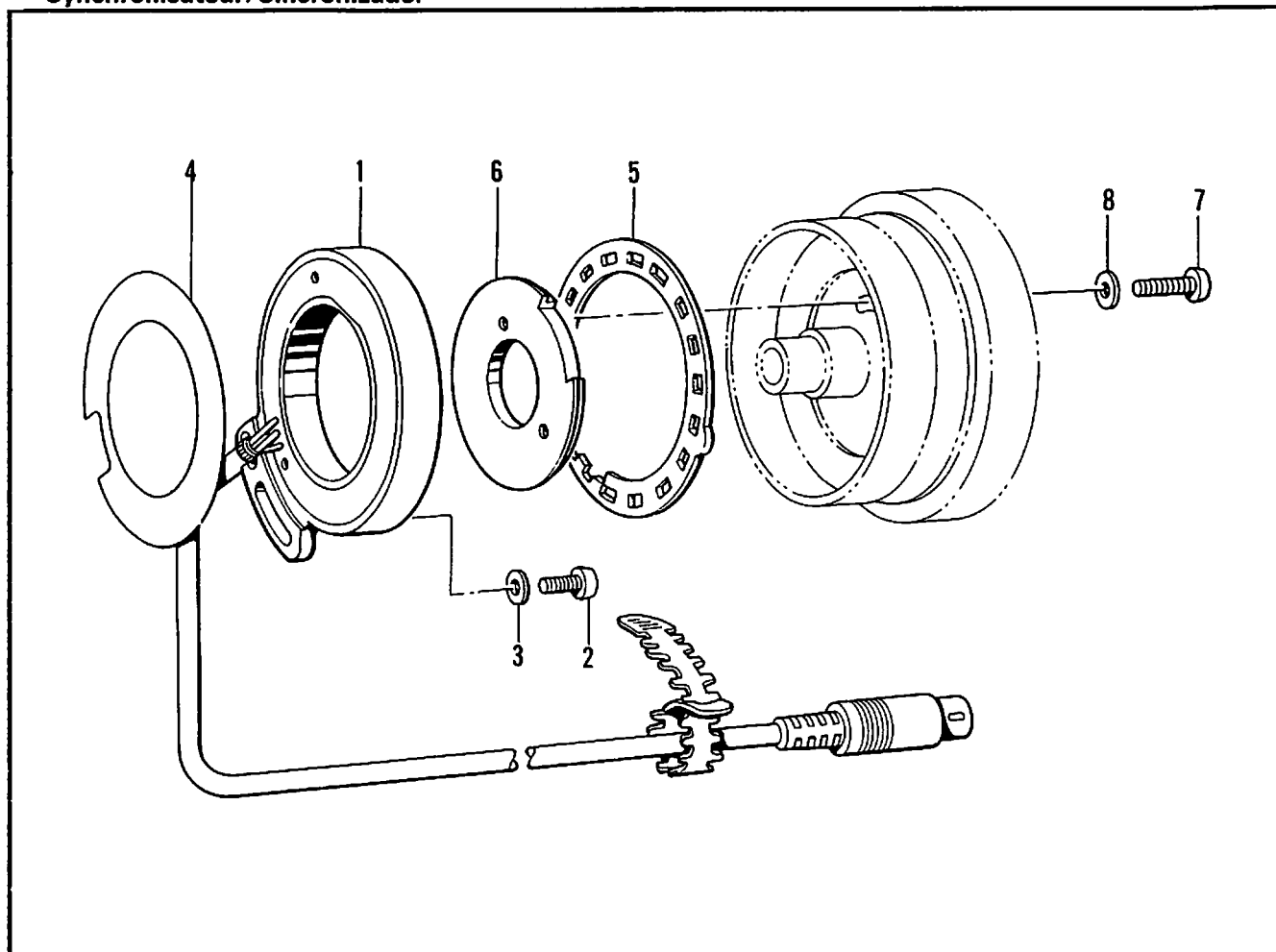

T. ゲージ部品関係 / Gauge mechanism / Lehrenvorrichtung /
Mécánisme de jauge / Mecanismo del galga

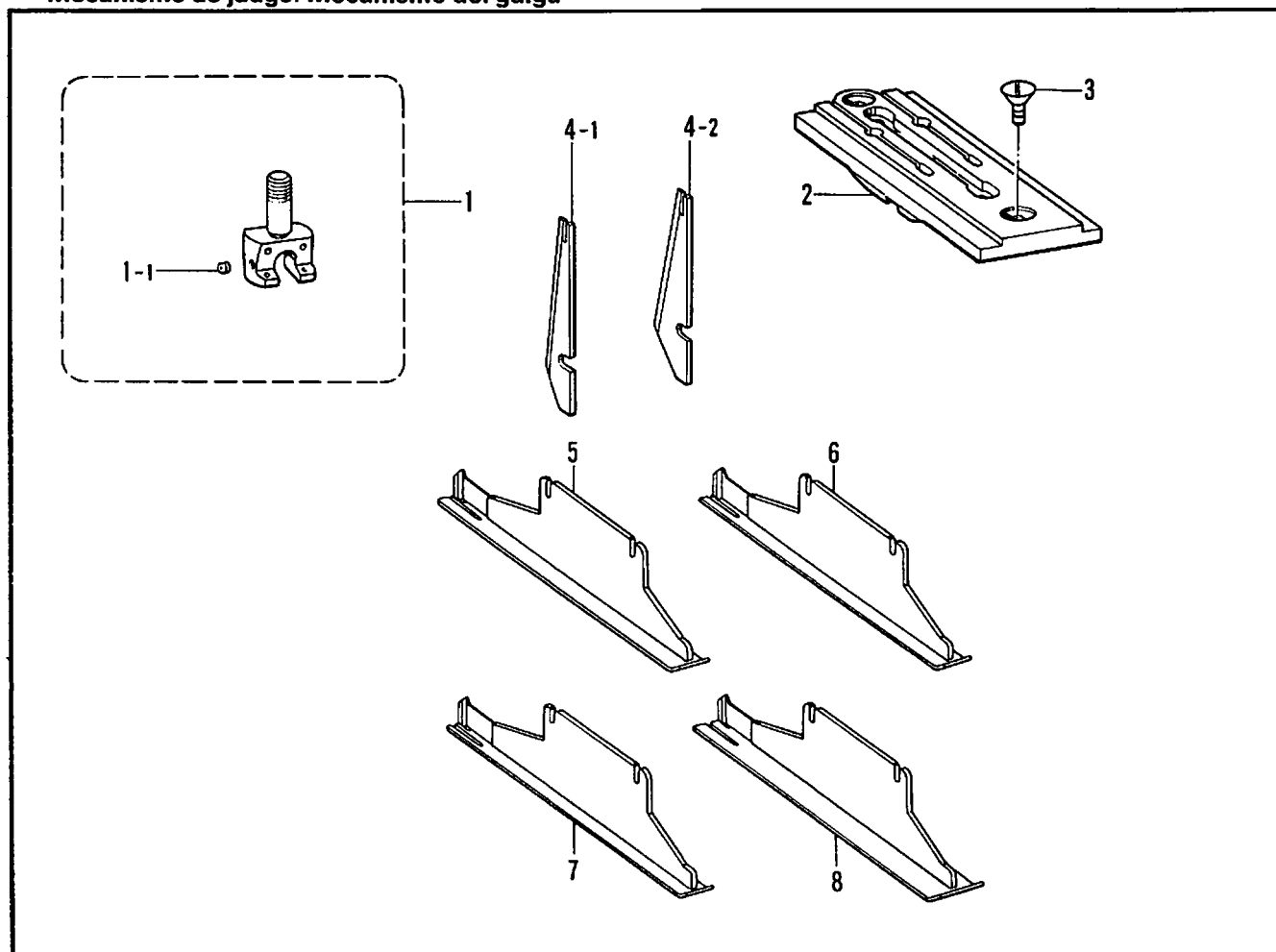

S. 針位置検出器関係 / Synchronizer / Synchronisator /
Synchronisateur / Sincronizador

REF.NO.	CODE	Q'TY	ヒンメイ	NAME OF PARTS	RMKS
1	237950001	1	シンクロナイザ"クミ#14G2	SYNCHRONIZER ASSY #14G2	
2	062711012	1	ナヘ"コ476-32X10	SCREW 4.76X10	
3	113431002	1	サ"ガ"ネ	WASHER	
4	S06241000	1	セ"ツインシート	INSULATION SEAT	
5	S06242001	1	ソクト"シレイイタ	SPEED COMMAND PLATE	
6	S14675001	1	ハリウエイタ	NEEDLE UPPER PLATE	
7	062681612	2	ナヘ"コ437-40X16	SCREW 4.37X16	
8	100645003	2	サ"ガ"ネ	WASHER	

T. ゲージ部品関係 / Gauge mechanism / Lehrenvorrichtung /
Mécánisme de jauge / Mecanismo del galga

REF.NO.	CODE	Q'TY	ヒンメイ	NAME OF PARTS	RMKS
1	*	1	ハリタ"キクミ	NEEDLE CLAMP ASSY	
1-1	146427001	2	アナトメネシ"3.18クホ"ミ	SET SCREW 3.18	
2	*	1	ハリイタ	NEEDLE PLATE	
3	100032003	2	サラネシ"4.37	SCREW 4.37	
4-1	S14050001	4	セラミツクコーナーメスS	CERAMIC CORNER KNIFE (S)	
4-2	S14051001	4	セラミツクコーナーメスL	CERAMIC CORNER KNIFE (L)	
5	S15602009	1	OFシ"ヨウキ"クミ 10MM	OFF-SET BINDER ASSY (10MM)	*
5	S15604009	1	OFシ"ヨウキ"クミ 12MM	OFF-SET BINDER ASSY (12MM)	*
5	S15606009	1	OFシ"ヨウキ"クミ 14MM	OFF-SET BINDER ASSY (14MM)	*
6	*	1	Cシ"ヨウキ"クミ	C BINDER ASSY	
7	*	1	Bシ"ヨウキ"クミ	B BINDER ASSY	
8	*	1	Dシ"ヨウキ"クミ	D BINDER ASSY	

U. 特別注文部品 / Option parts / Sonderzubehör /
Pièces en option / Piezas opcionales

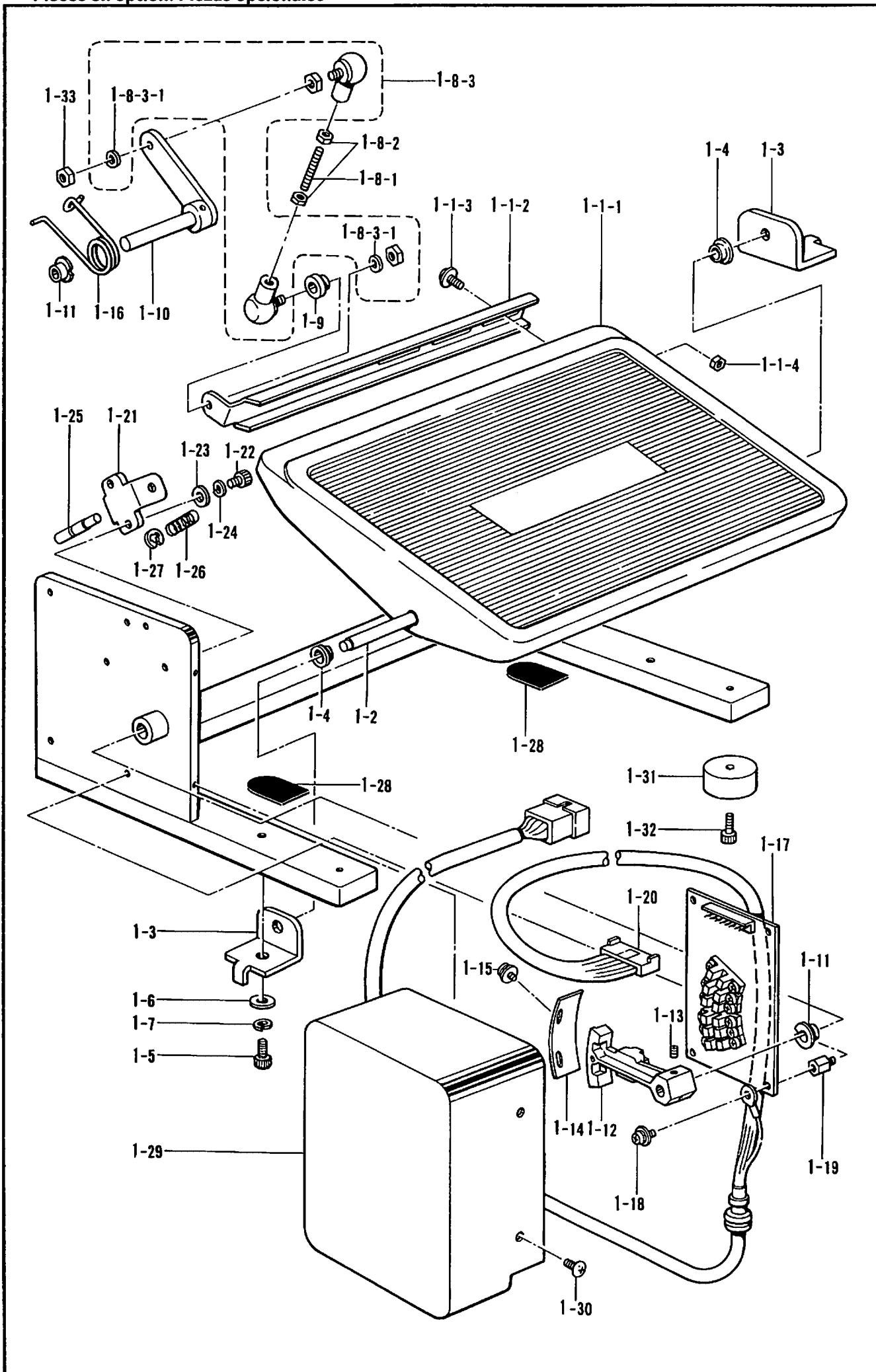

U. 特別注文部品/Option parts/Sonderzubehör/
Pièces en option/Piezas opcionales

REF.NO.	CODE	QTY	ヒンメイ	NAME OF PARTS	RMKS
1	S32012009	1	フットスイッチクミ	FOOT SWITCH ASSY	
1-1-1	183387009	1	フミイタ クミ	TREADLE ASSY	
1-1-2	119709003	1	レンカントリツクウテ	CONNECTING ROD SET ARM	
1-1-3	S06694001	2	ナヘ"コヒラサ"6X16	WASHER SCREW 6X16	
1-1-4	021060106	2	ナツト1シユ6	NUT 6	
1-2	119706001	1	フミイタシ"ク	TREADLE SHAFT	
1-3	119707003	2	フミイタシ"クウケ	TREADLE SHAFT BRACKET	
1-4	119708001	2	フミイタシ"クウケカラー	TREADLE SHAFT BRACKET COLLAR	
1-5	018082036	2	アナホ"ルト8X20	BOLT 8X20	
1-6	025080236	2	ヒラサ"ガ"ネチユウ8	PLAIN WASHER 8	
1-7	028080246	2	ハ"ネサ"ガ"ネ2-8	SPRING WASHER 2-8	
1-8	S08411001	1	レンカンクミ	CONNECTING ROD ASSY	
1-8-1	S08412001	1	レンカン	CONNECTING ROD	
1-8-2	021060106	2	ナツト1シユ6	NUT 6	
1-8-3	133792101	2	シ"ョイントクミ	JOINT ASSY	
1-8-3-1	028060243	2	ハ"ネサ"ガ"ネ2-6	SPRING WASHER 2-6	
1-9	114859001	2	レンカンカラー	CONNECTING ROD COLLAR	
1-10	S08413001	1	フットスイッチレバ"ークミ	FOOT SWITCH LEVER ASSY	
1-11	S08416000	2	ト"ライヘ"アリング"	BUSH BM0806F15FB	
1-12	S08417000	1	アーム	ARM	
1-13	012400836	2	アナヒラ4X8	SET SCREW 4X8	
1-14	S08418000	1	ホトカプ"ラト"ウサイタ	PHOTO COUPLER ACTUATE PLATE	
1-15	052400806	2	ナヘ"コハ"ネヒラ4X8	WASHER SCREW 4X8	
1-16	S08419001	1	フットスイッチハ"ネ	SPRING	
1-17	S08420000	1	キハ"ンB439013クミ	CIRCUIT BOARD B439013 ASSY	
1-18	052400806	4	ナヘ"コハ"ネヒラ4X8	WASHER SCREW 4X8	
1-19	S08421000	4	スヘ"ーサ	SPACER	
1-20	S08422000	1	FSWハ"ーネスクミ	FOOT SWITCH HARNESS ASSY	
1-21	S08423001	1	フミカ"エシ"ク	INDICATION SUPPORT	
1-22	018401236	2	アナホ"ルト4X12	BOLT 4X12	
1-23	025040236	2	ヒラサ"ガ"ネチユウ4	PLAIN WASHER 4	
1-24	028040246	2	ハ"ネサ"ガ"ネ2-4	SPRING WASHER 2-4	
1-25	S08424001	1	フミカ"エシ"ク	INDICATION SHAFT	
1-26	147843001	1	ラツクモト"シハ"ネ	SPRING	
1-27	048060342	1	トメフE6	STOP RING E6	
1-28	S14197000	2	クツシヨ"ンC	CUSHION (C)	
1-29	S08426009	1	フットスイッチカハ"ー	FOOT SWITCH COVER	
1-30	008400604	4	+トラスコ4X6	SCREW 4X6	
1-31	S01830000	4	ハ"ネルカハ"ーアシ	PANEL COVER LEG	
1-32	018401636	4	アナホ"ルト4X16	BOLT 4X16	
1-33	021060106	1	ナツト1シユ6	NUT 6	

V. 動力台関係/Power table/Motorgestell/
Mécánisme du plateau de la machine/Mecanismo de la mesa de la máquina

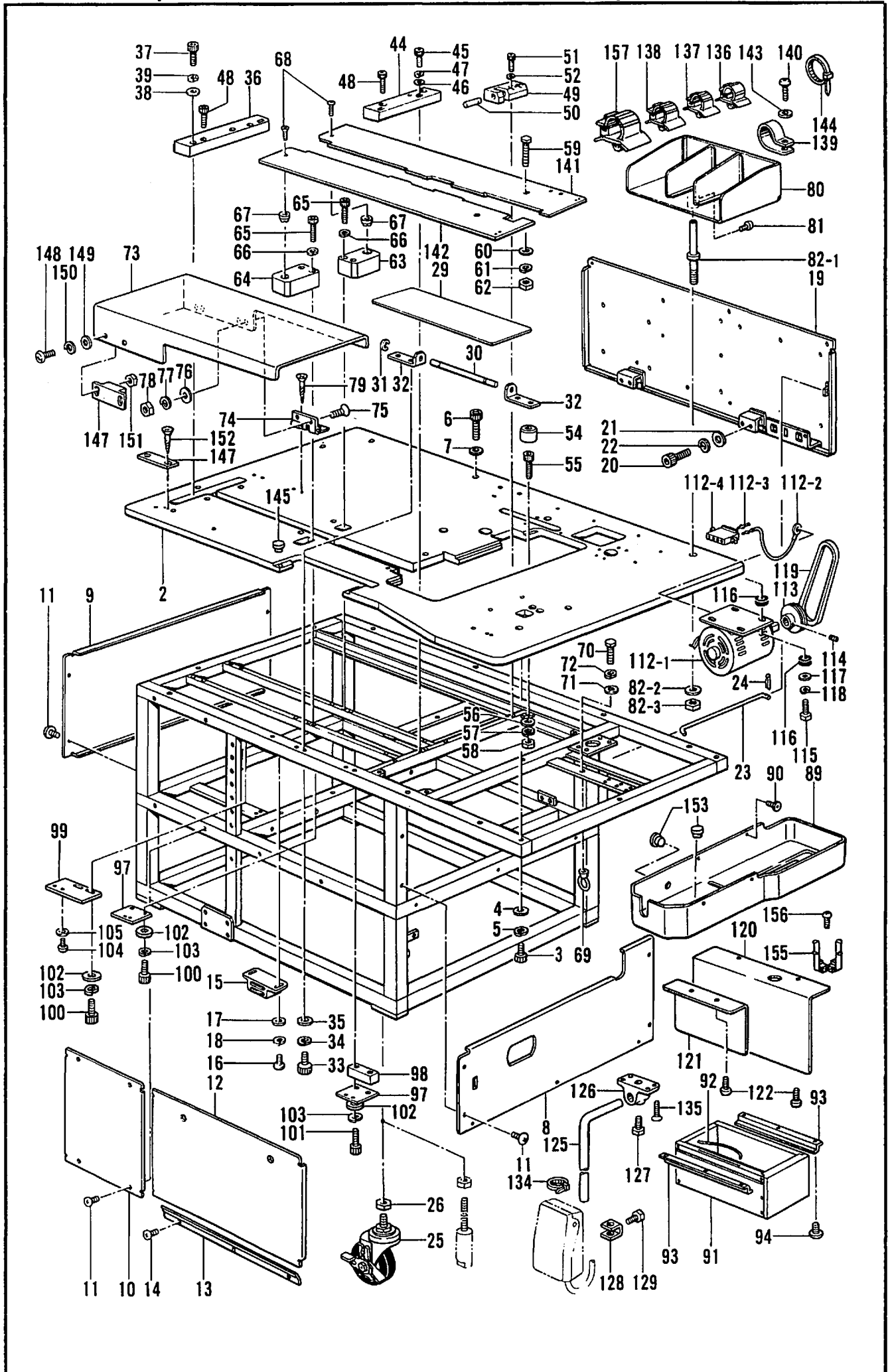

V. 動力台関係/Power table/Motorgestell/
Mécanisme du plateau de la machine/Mecanismo de la mesa de la máquina

REF.NO.	CODE	Q'TY	ヒンメイ	NAME OF PARTS	RMKS
2	S31621009	1	BAS605テーブル	BAS-605 TABLE	
3	018501436	7	アナボルト5X14	BOLT 5X14	
4	025050236	7	ヒラサカネチユウ5	PLAIN WASHER 5	
5	028050246	7	ハネサカネ2-5	SPRING WASHER 2-5	
6	018401636	11	アナボルト4X16	BOLT 4X16	
7	025040236	11	ヒラサカネチユウ4	PLAIN WASHER 4	
8	S31226009	1	マエカハ-	FRONT COVER	
9	S08185009	1	ウシロカハ-	REAR COVER	
10	S08186009	1	ヒタリRカハ-	LEFT (R) COVER	
11	008400604	12	+トラスコ4X6	SCREW 4X6	
12	S31227009	1	ヒタリFカハ-	LEFT (F) COVER	
13	S31622009	1	カハ-ウケ	COVER SUPPORT	
14	008400604	3	+トラスコ4X6	SCREW 4X6	
15	S09448000	2	マグネット	MAGNET	
16	062300616	4	ナヘコM3X6	SCREW M3X6	
17	025030236	4	ヒラサカネチユウ3	PLAIN WASHER 3	
18	028030246	4	ハネサカネ2-3	SPRING WASHER 2-3	
19	S31228009	1	ミキカハ-	RIGHT COVER	
20	018501236	4	アナボルト5X12	BOLT 5X12	
21	025050236	4	ヒラサカネチユウ5	PLAIN WASHER 5	
22	028050246	4	ハネサカネ2-5	SPRING WASHER 2-5	
23	S08191001	1	トヒラステー	DOOR STAY	
24	114909000	1	ワリピン	COTTER PIN	
25	S00403100	4	キヤスター	CASTER	
26	021200203	4	ナット2シユ20	NUT 20	
29	S08194001	1	ホシヨテーブル	SUB TABLE	
30	S08368001	1	ホシヨテーブルヨウシク	SHAFT	
31	048050342	2	トメワE5	STOP RING E5	
32	S08270001	2	ホシヨテーブルウケ	SUB TABLE SUPPORT	
33	018500836	4	アナボルト5X8	BOLT 5X8	
34	028050246	4	ハネサカネ2-5	SPRING WASHER 2-5	
35	025050236	4	ヒラサカネチユウ5	PLAIN WASHER 5	
36	S31623001	1	トリツケタイウシロ	SET BASE REAR	
37	018062036	2	アナボルト6X20	BOLT 6X20	
38	025060236	2	ヒラサカネチユウ6	PLAIN WASHER 6	
39	028060246	2	ハネサカネ2-6	SPRING WASHER 2-6	
44	S14796101	1	トリツケタイマエ	SET BASE FRONT	
45	018062036	2	アナボルト6X20	BOLT 6X20	
46	025060236	2	ヒラサカネチユウ6	PLAIN WASHER 6	
47	028060246	2	ハネサカネ2-6	SPRING WASHER 2-6	
48	018082536	4	アナボルト8X25	BOLT 8X25	
49	S14797001	2	ヒンシウケ	HINGE SUPPORT	
50	S14798001	2	ローレットピン	KNURLING PIN	
51	018401636	4	アナボルト4X16	BOLT 4X16	
52	028040246	4	ハネサカネ2-4	SPRING WASHER 2-4	
54	S08205000	4	クツシヨ	CUSHION	
55	018061636	4	アナボルト6X16	BOLT 6X16	
56	025060236	4	ヒラサカネチユウ6	PLAIN WASHER 6	
57	028060246	4	ハネサカネ2-6	SPRING WASHER 2-6	
58	021060102	4	ナット1シユ6	NUT 6	
59	S08200001	2	イチキメボルト	POSITIONING BOLT	
60	025060236	2	ヒラサカネチユウ6	PLAIN WASHER 6	
61	028060246	2	ハネサカネ2-6	SPRING WASHER 2-6	
62	021060206	2	2シユナット6	NUT 6	
63	S09449001	1	シデンピンアンナイR	PIN GUIDE (R)	
64	S08201001	1	シデンピンアンナイL	PIN GUIDE (L)	
65	018401636	4	アナボルト4X16	BOLT 4X16	
66	028040246	4	ハネサカネ2-4	SPRING WASHER 2-4	
67	S08197001	2	シデンピン	PIN	
68	004300513	2	+サラコ3X5	SCREW 3X5	
69	S07026001	1	エアガンフック	AIR GUN HOOK	
70	017082203	1	ボルト8X22	BOLT 8X22	

V. 動力台関係/Power table/Motorgestell/
Mécanisme du plateau de la machine/Mecanismo de la mesa de la máquina

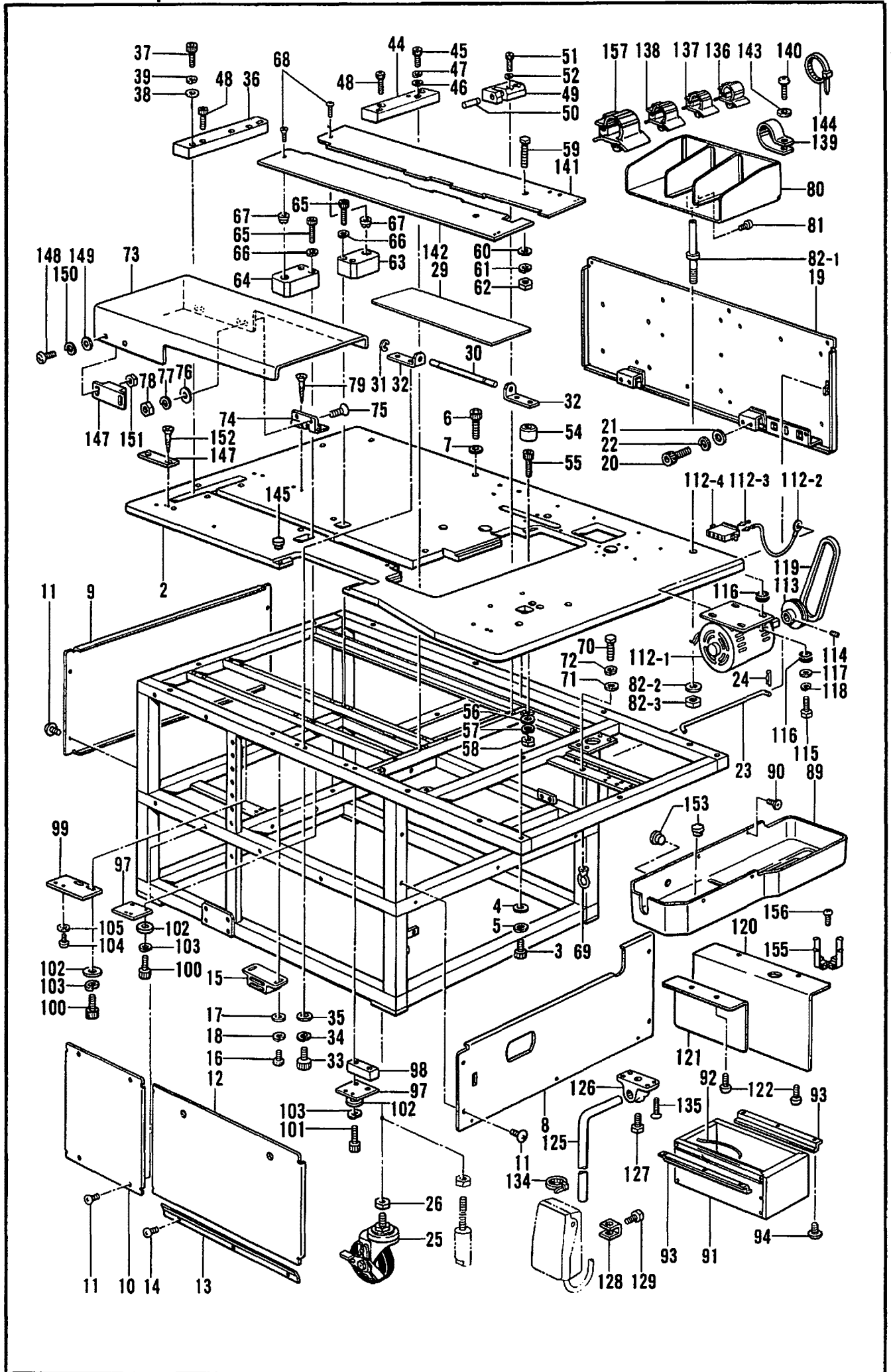

V. 動力台関係/Power table/Motorgestell/
Mécanisme du plateau de la machine/Mecanismo de la mesa de la máquina

REF.NO.	CODE	QTY	ヒンメイ	NAME OF PARTS	RMKS
71	025080236	1	ヒラサ"カ"ネチユウ8	PLAIN WASHER 8	
72	028080246	1	ハ"ネサ"カ"ネ2-8	SPRING WASHER 2-8	
73	S08206009	1	トップ"カ"ハ"	TOP COVER	
74	S09690001	2	チヨウハ"ン	HINGE	
75	004301003	4	+サラコ3X10	SCREW 3X10	
76	025030236	4	ヒラサ"カ"ネチユウ3	PLAIN WASHER 3	
77	028030246	4	ハ"ネサ"カ"ネ2-3	SPRING WASHER 2-3	
78	021300103	4	ナツト1 シユ3	NUT 3	
79	034311302	4	+サラモクネシ"3.1X13	SCREW 3.1X13	
80	S08221009	1	ヌノウケサラ	CLOTH SUPPORT DISC	
81	062060806	2	ナヘ"コ6X8	SCREW 6X8	
82	S10559009	1	ヌノウケサラシチユウクミ	DISC STUD ASSY	
82-1	S08222009	1	ヌノウケサラシチユウ	DISC STUD	
82-2	150206002	1	ヒラサ"カ"ネ16	PLAIN WASHER 16	
82-3	150191001	1	ロツカクナツトU5/8	NUT 5/8	
89	S15673001	1	オイルハ"ン	OIL PAN	
90	008300604	4	+トラスコ3X6	SCREW 3X6	
91	S08192009	1	ヒキタ"シ	DRAWER	
92	101073001	1	ヒキタ"シユテイハ"ネ	SPRING	
93	S08427101	2	ヒキタ"シササエ	DRAWER SUPPORT	
94	008300604	4	+トラスコ3X6	SCREW 3X6	
97	S08224001	2	センサートリツケタ"イ	SENSOR SET BASE	
98	S08225001	1	スペ"ーサ	SPACER	
99	S09450001	1	センサトリツケタ"イル	SENSOR SET BASE (L)	
100	018401236	4	アナボ"ルト4X12	BOLT 4X12	
101	018402536	2	アナボ"ルト4X25	BOLT 4X25	
102	025040236	6	ヒラサ"カ"ネチユウ4	PLAIN WASHER 4	
103	028040246	6	ハ"ネサ"カ"ネ2-4	SPRING WASHER 2-4	
104	002301203	6	+ナヘ"コ3X12	SCREW 3X12	
105	025030233	6	ヒラサ"カ"ネチユウ3	PLAIN WASHER 3	
112	S08089001	1	3ソウモータ200Vクミ	3-PHASE MOTOR 200V ASSY	
112-1	159812001	1	モ"ータ	MOTOR	
112-2	S00614000	1	モ"ータアースセン	MOTOR EARTH WIRE	
112-3	S03328000	3	ピンターミナルオスL	TERMINAL PIN (L)(MALE)	
112-4	S00603000	1	コネクタ4P	4P CONNECTOR	
113	159386001	1	モ"ータプ"ーリ3200/60	MOTOR PULLEY 3200/60 (14MM)	
114	014760622	2	アノメネシ"5.95	SET SCREW 5.95	
115	017062503	4	6カクボ"ルト6X25	BOLT 6X25	
116	S00617000	8	ボ"ウシンゴ"ムカラ"ー	RUBBER COLLAR	
117	025060336	4	ヒラサ"カ"ネタ"イ6	PLAIN WASHER 6	
118	028060246	4	ハ"ネサ"カ"ネ2-6	SPRING WASHER 2-6	
119	S18707141	1	V"ベルトMシロ (M41)	V-BELT M WHITE (M41)	
120	S31729001	1	ヘ"ルトカハ"ーR	BELT COVER (R)	
121	S16255001	1	モ"ーターカハ"ー	MOTOR COVER	
122	008400604	4	+トラスコ4X6	SCREW 4X6	
125	S08220001	1	ヒザ"スイッチタテシ"ク	KNEE SWITCH VERTICAL SHAFT	
126	142027001	1	ヒザ"スイッチタテシ"クウケ	KNEE SWITCH SHAFT BRACKET	
127	100463001	1	4カクボ"ルト7.94	BOLT 7.94	
128	114967001	1	ヒザ"アテストツパ"	KNEE LIFTER PLATE STOPPER	
129	110087001	1	ボ"ルト5.95	BOLT 5.95	
134	S04557000	1	ハンタイPLTIM	BAND PLTIM	
135	004401003	4	+サラコ4X10	SCREW 4X10	
136	150349001	4	コート"クランプ"10	CORD CLAMP 10-L	
137	S09141000	2	コート"クランプ"16L	CORD CLAMP 16-L	
138	S09142000	9	コート"クランプ"20L	CORD CLAMP 20-L	
139	S00470000	1	コート"ホルダ"ー 16N	CORD HOLDER (16N)	
140	062401006	1	ナヘ"コ4X10	SCREW 4X10	
141	*	1	キジ"スヘ"リイタR	SLIDE PLATE (R)	
142	*	1	キジ"スヘ"リイタL	SLIDE PLATE (L)	
143	025040233	1	ヒラサ"カ"ネチユウ4	PLAIN WASHER 4	
144	149809000	1	タイラツプ"L	BEAD BAND (L)	
145	104821009	4	メクラセン	OIL CAP	

V. 動力台関係/Power table/Motorgestell/
 Mécanisme du plateau de la machine/Mecanismo de la mesa de la máquina

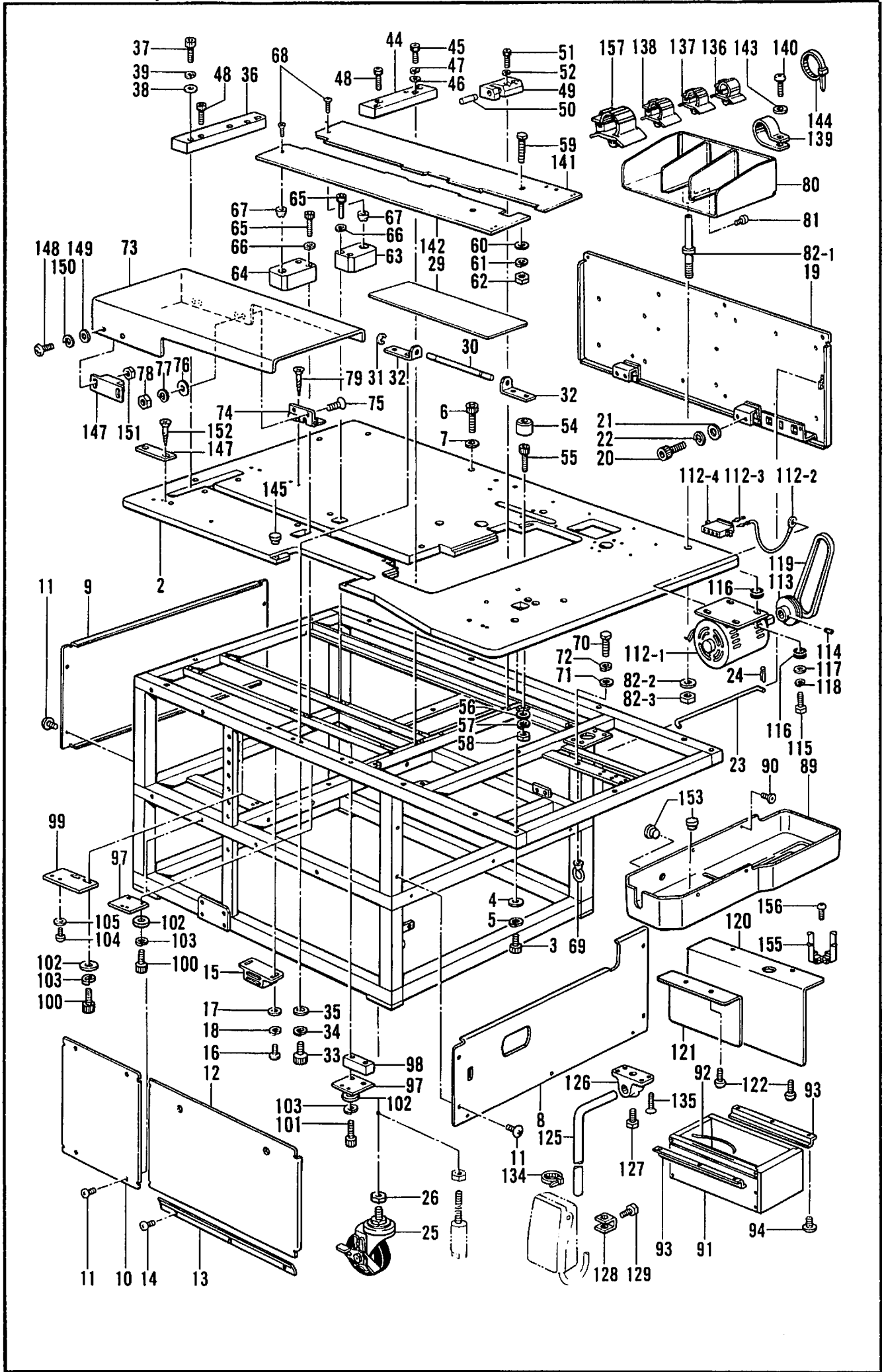

V. 動力台関係 / Power table / Motorgestell /

Mécanisme du plateau de la machine / Mecanismo de la mesa de la máquina

REF.NO.	CODE	Q'TY	ヒンメイ	NAME OF PARTS	RMKS
147	S09448000	1	マグネット	MAGNET	
148	062300806	2	ナヘ"コ3X8	SCREW M3X8	
149	025030233	2	ヒラサ"カ"ネチユウ3	PLAIN WASHER 3	
150	028030243	2	ハ"ネサ"カ"ネ2-3	SPRING WASHER 2-3	
151	021300103	2	ナツト1シユ3	NUT 3	
152	034311302	2	+ サラモクネシ"3.1X13	SCREW 3.1X13	
153	150756009	3	メクラセン	OIL CAP	
155	133172003	1	アブ"ラサシタ"イ	OIL BRACKET	
156	008400604	1	+トラスコ4X6	SCREW 4X6	
157	S31760000	1	CKSクランプ"26L	(CKS) CORD CLAMP 26-L	

W1. 特別注文部品 / Option parts / Sonderzubehör /
Pièces en option / Piezas opcionales

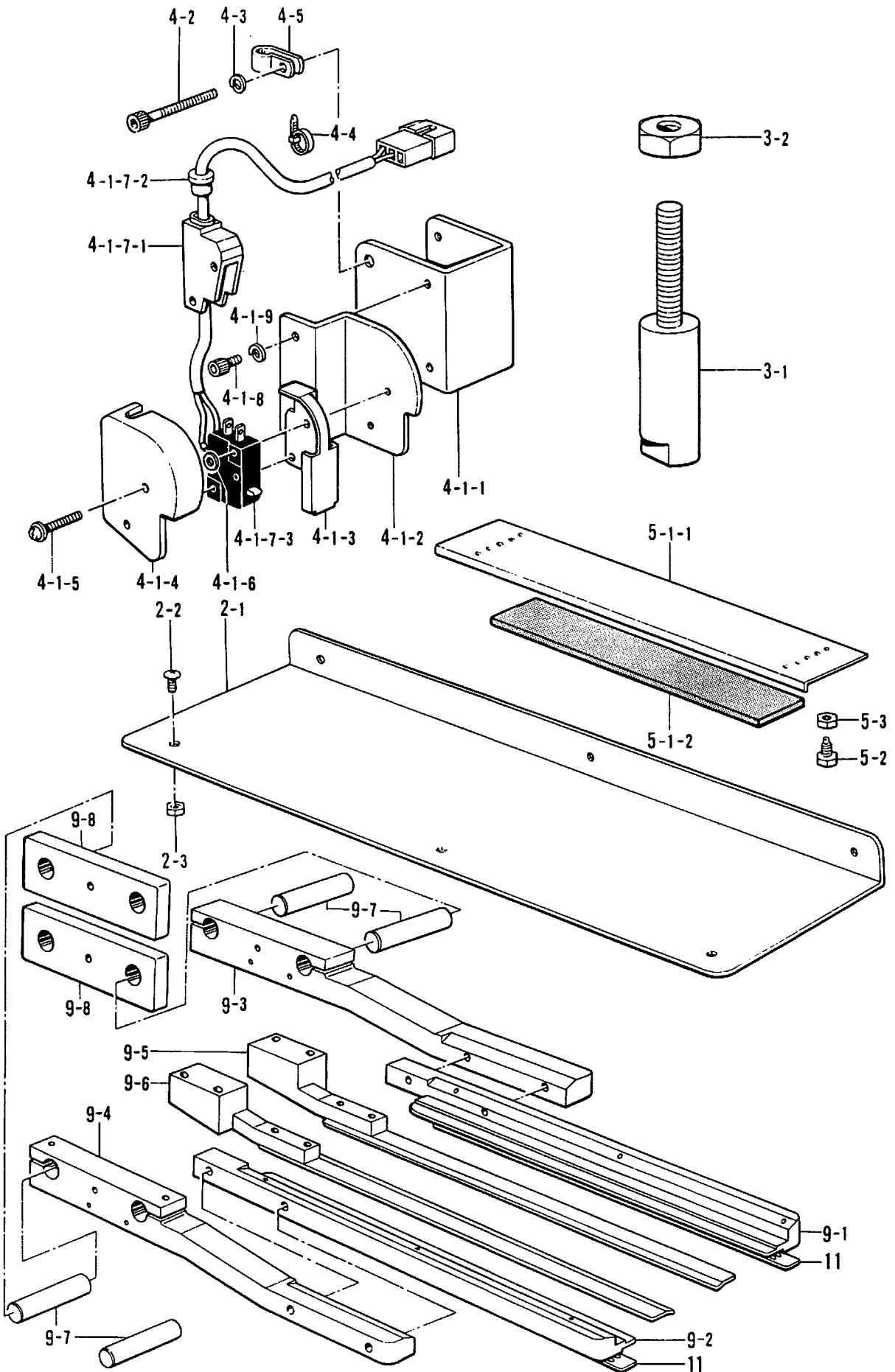

W1. 特別注文部品 / Option parts / Sonderzubehör /
Pièces en option / Piezas opcionales

REF.NO.	CODE	Q'TY	ヒンメイ	NAME OF PARTS	RMKS
2	S11502009	1	ホシ"ヨダ"イクミ	AUXILIARY BASE ASSY	
2-1	S09687009	1	ホシ"ヨダ"イ	AUXILIARY BASE	
2-2	008400604	3	+トラスコ4X6	SCREW 4X6	
2-3	021400103	3	ナット1シユ4	NUT 4	
3	S11148001	4	チヨウセツネシ"クミ	ADJUST SCREW ASSY	
3-1	S00402001	4	チヨウセツネシ"	ADJUST SCREW	
3-2	021200203	4	ナット2シユ20	NUT 20	
4	S11503009	1	テトスタートスイッチクミ	HAND START SWITCH ASSY	
4-1	S11334001	1	テトスイッチクミ	HAND SWITCH ASSY	
4-1-1	S11335009	1	スタートスイッチダイ	START SWITCH BRACKET	
4-1-2	S04607009	1	スイッチトリツケイタ	SWITCH SETTING PLATE	
4-1-3	149069101	1	アクチュエータ	ACTUATOR	
4-1-4	149070009	1	スイッチカハ"	SWITCH COVER	
4-1-5	522990001	2	サ"ツキシメネシ"3X19	SCREW 3X19	
4-1-6	025030233	2	ヒラサ"カ"ネチユウ3	PLAIN WASHER 3	
4-1-7	S11336009	1	スイッチクミ	SWITCH ASSY	
4-1-7-1	143531000	1	マイクロSWカハ"	MICRO SWITCH COVER	
4-1-7-2	146080009	1	コード"フ"シユ	CORD BUSH	
4-1-7-3	149066001	1	マイクロスイッチ	MICRO SWITCH	
4-1-8	018400622	2	アナホ"ルト4X6	BOLT 4X6	
4-1-9	028040242	2	ハ"ネサ"カ"ネ2-4	SPRING WASHER 2-4	
4-2	155055001	2	アナホ"ルト4X45	BOLT 4X45	
4-3	028040242	2	ハ"ネサ"カ"ネ2-4	SPRING WASHER 2-4	
4-4	S04557000	2	ハンタイPLTIM	BAND PLTIM	
4-5	149547000	1	コード"オサエ	CORD HOLDER (4N)	
5	S11504001	1	フラツフ"カ"イト"クミ	FLAP GUIDE ASSY	
5-1	S11505000	1	フラツフ"カ"イト"	FLAP GUIDE	
5-1-1	S11083000	1	ガ"イト"イタ	GUIDE PLATE	
5-1-2	S11506000	1	ゴムイタジ"シヤク	RUBBER MAGNET	
5-2	S11084001	2	フラツフ"カ"イト"ピン	PIN	
5-3	021400103	2	ナット1シユ4	NUT 4	
9	S29936001	1	ホソハハ"オオオサエセット	CARRIAGE FEED SET (NARROW)	
9-1	S29937001	1	オオオサIR-S	CARRIAGE FEED (R-S)	
9-2	S29938001	1	オオオサIL-S	CARRIAGE FEED (L-S)	
9-3	S29939001	1	オオオサイトリツケイタR-S	CARRIAGE FEED FITTING PLATE (R-S)	
9-4	S29940001	1	オオオサイトリツケイタL-S	CARRIAGE FEED FITTING PLATE (L-S)	
9-5	S29941001	1	オリコミイタR-S	FOLDING PLATE (R-S)	
9-6	S29942001	1	オリコミイタL-S	FOLDING PLATE (L-S)	
9-7	S29943001	4	ピン10X45	PIN 10X45	
9-8	S29944001	2	オオオサエスヘ"ーサ	CARRIAGE FEED SPACER	
11	S30040000	2	オオオサエゴムS	PRESSER RUBBER (S)	

W2. 特別注文部品 (ダーツノバシ) / Option parts (Darts stretcher) / Sonderzubehör (Abnäherstrecker) / Pièces en option (tendeur pour pince) / Piezas opcionales (estirador de sisa)

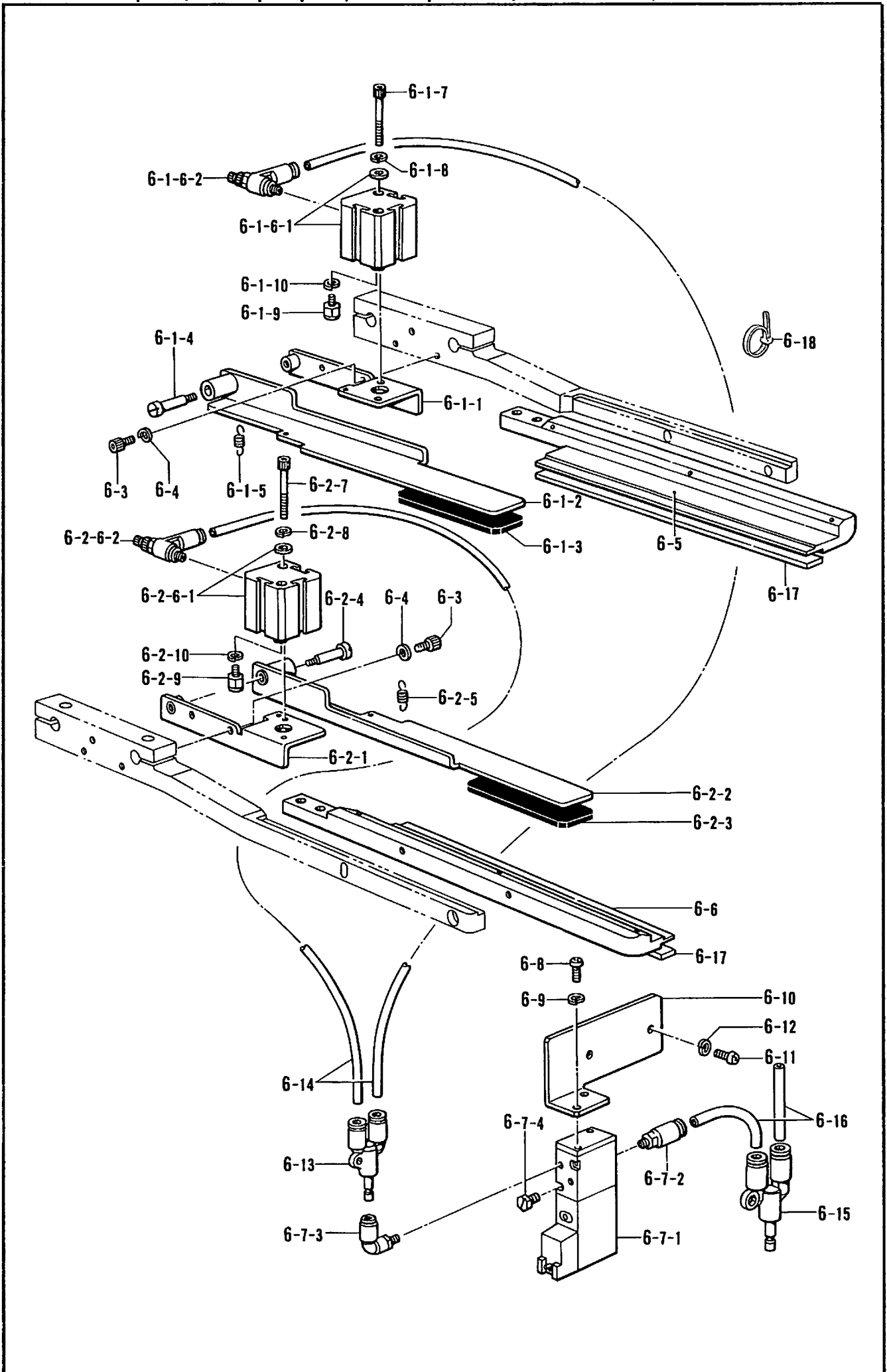

W2. 特別注文部品 (ダーツノバシ)/Option parts (Darts stretcher)/Sonderzubehör (Abnäherstrecker)/
Pièces en option (tendeur pour pince)/Piezas opcionales (estirador de sisa)

REF.NO.	CODE	Q'TY	ヒンメイ	NAME OF PARTS	RMKS
6	S15890001	1	ダーツ1ハシクミ610	DARTS STRETCHER ASSY	
6-1	S15891001	1	ダーツオサエRクミ	DARTS PRESSER (R) ASSY	
6-1-1	S13570001	1	DブラケットR	DARTS BRACKET (R)	
6-1-2	S13572001	1	ダーツオサエR	DARTS PRESSER (R)	
6-1-3	S13576100	1	ダーツオサエゴム	DARTS PRESSER RUBBER	
6-1-4	159732001	1	タネジ4.37	STUD SCREW 4.37	
6-1-5	S10268001	1	イトマキウテハネ	SPRING	
6-1-6	S13574000	1	シリンダクミ	CYLINDER ASSY	
6-1-6-1	S13575000	1	シリンダ16X10	CYLINDER (16X10)	
6-1-6-2	S06890000	1	スピコンツキテM5-4	SPEED CONTROLLER JOINT M5-4	
6-1-7	S12642001	2	アナボルト3X35	BOLT 3X35	
6-1-8	028030243	2	ハネサガネ2-3	SPRING WASHER 2-3	
6-1-9	S04411001	1	Bクランプヘッド	(B) CLAMP HEAD	
6-1-10	028030243	1	ハネサガネ2-3	SPRING WASHER 2-3	
6-2	S15892001	1	ダーツオサエLクミ	DARTS PRESSER (L) ASSY	
6-2-1	S13571001	1	DブラケットL	DARTS BRACKET (L)	
6-2-2	S13573001	1	ダーツオサエL	DARTS PRESSER (L)	
6-2-3	S13576100	1	ダーツオサエゴム	DARTS PRESSER RUBBER	
6-2-4	159732001	1	タネジ4.37	STUD SCREW 4.37	
6-2-5	S10268001	1	イトマキウテハネ	SPRING	
6-2-6	S13574000	1	シリンダクミ	CYLINDER ASSY	
6-2-6-1	S13575000	1	シリンダ16X10	CYLINDER (16X10)	
6-2-6-2	S06890000	1	スピコンツキテM5-4	SPEED CONTROLLER JOINT M5-4	
6-2-7	S12642001	2	アナボルト3X35	BOLT 3X35	
6-2-8	028030243	2	ハネサガネ2-3	SPRING WASHER 2-3	
6-2-9	S04411001	1	Bクランプヘッド	(B) CLAMP HEAD	
6-2-10	028030243	1	ハネサガネ2-3	SPRING WASHER 2-3	
6-3	018400822	4	アナボルト4X8	BOLT 4X8	
6-4	028040242	4	ハネサガネ2-4	SPRING WASHER 2-4	
6-5	S14063001	1	オオオサエR-DTS	BIG PRESSER (R-DTS)	
6-6	S14062001	1	オオオサエL-DTS	BIG PRESSER (L-DTS)	
6-7	S13577000	1	バルブユニットDTS	VALVE UNIT (DTS)	
6-7-1	S13578000	1	バルブVZ3120	VALVE VZ3120	
6-7-2	S14145000	1	ハーフユニオン06-M5	HALF UNION 06-M5	
6-7-3	S11426000	1	エルボユニオン4M5	ELBOW UNION 4M5	
6-7-4	156096000	1	M5プラグ	M5 PLUG	
6-8	002301003	2	ナハコネジ3X10	SCREW 3X10	
6-9	028030243	2	ハネサガネ2-3	SPRING WASHER 2-3	
6-10	S13579001	1	バルブブラケット	VALVE BRACKET	
6-11	062500812	2	ナハコ5X8	SCREW 5X8	
6-12	028050242	2	ハネサガネ2-5	SPRING WASHER 2-5	
6-13	S08178000	1	ブランチUY-4	BRANCH UY-4	
6-14	S08172000	2	エアホース4-K	AIR TUBE 4-K (L=1630)	
6-15	S14146000	1	ブランチUY-6	BRANCH UY-6	
6-16	S08146000	2	エアホース6-A	AIR TUBE 6-A (L=135)	
6-17	S08267003	2	オオオサエゴム	CARRIAGE FEED RUBBER	
6-18	S04557000	7	パンタイPLTIM	BAND PLTIM	

W3. 特別注文部品 (エアージェクター)/Option parts (Air ejector)/Sonderzubehör (Luftausstosser)/
Pièces en option (éjecteur d'air)/Piezas opcionales (eyector de aire)

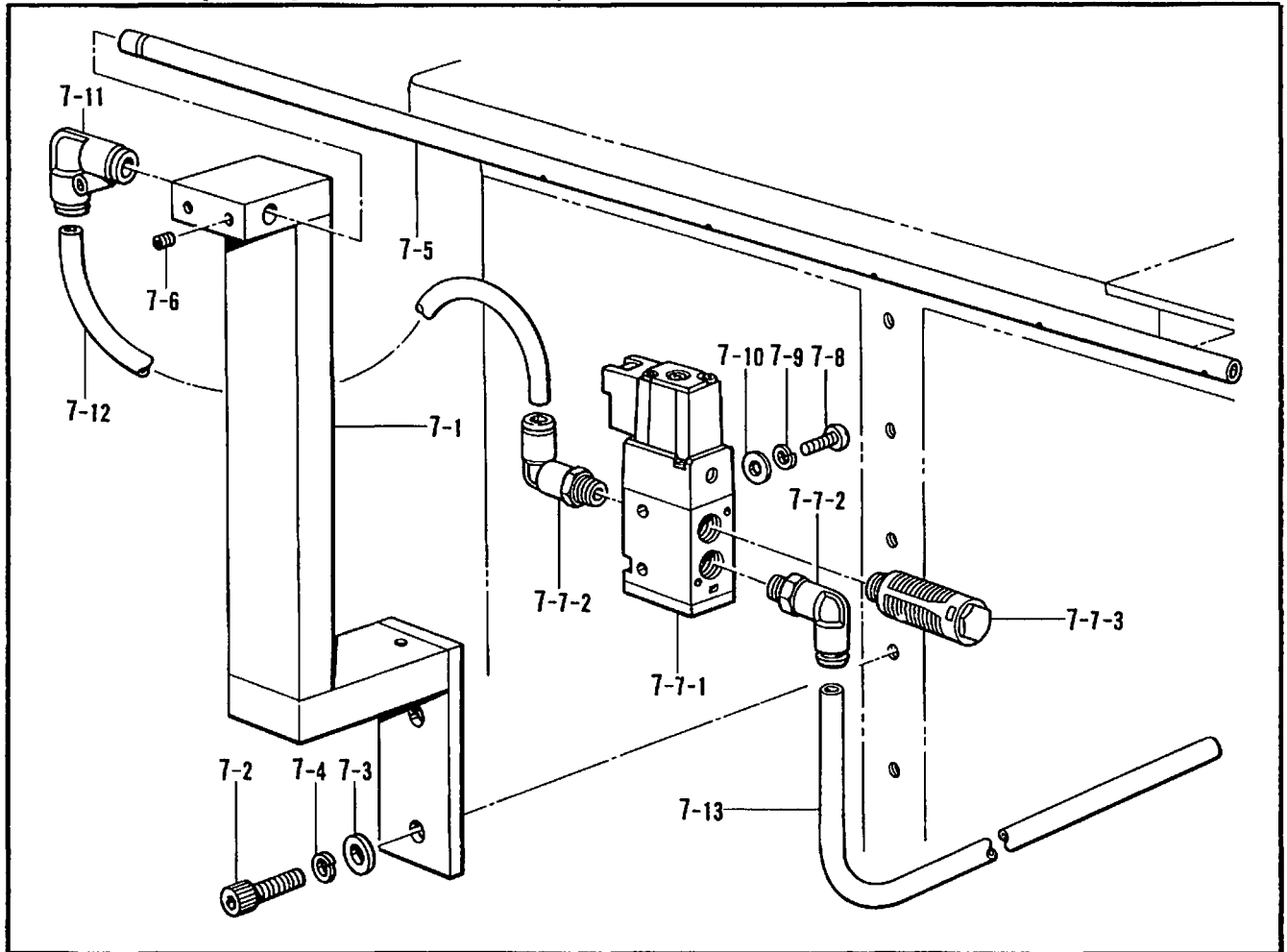

W4. 特別注文部品 (下送り装置)/Option parts (Bottom feed set)/Sonderzubehör (Untertransportsatz)/
Pièces en option (Jeu d'entraînement inférieur)/Piezas opcionales (Juego de alimentación inferior)

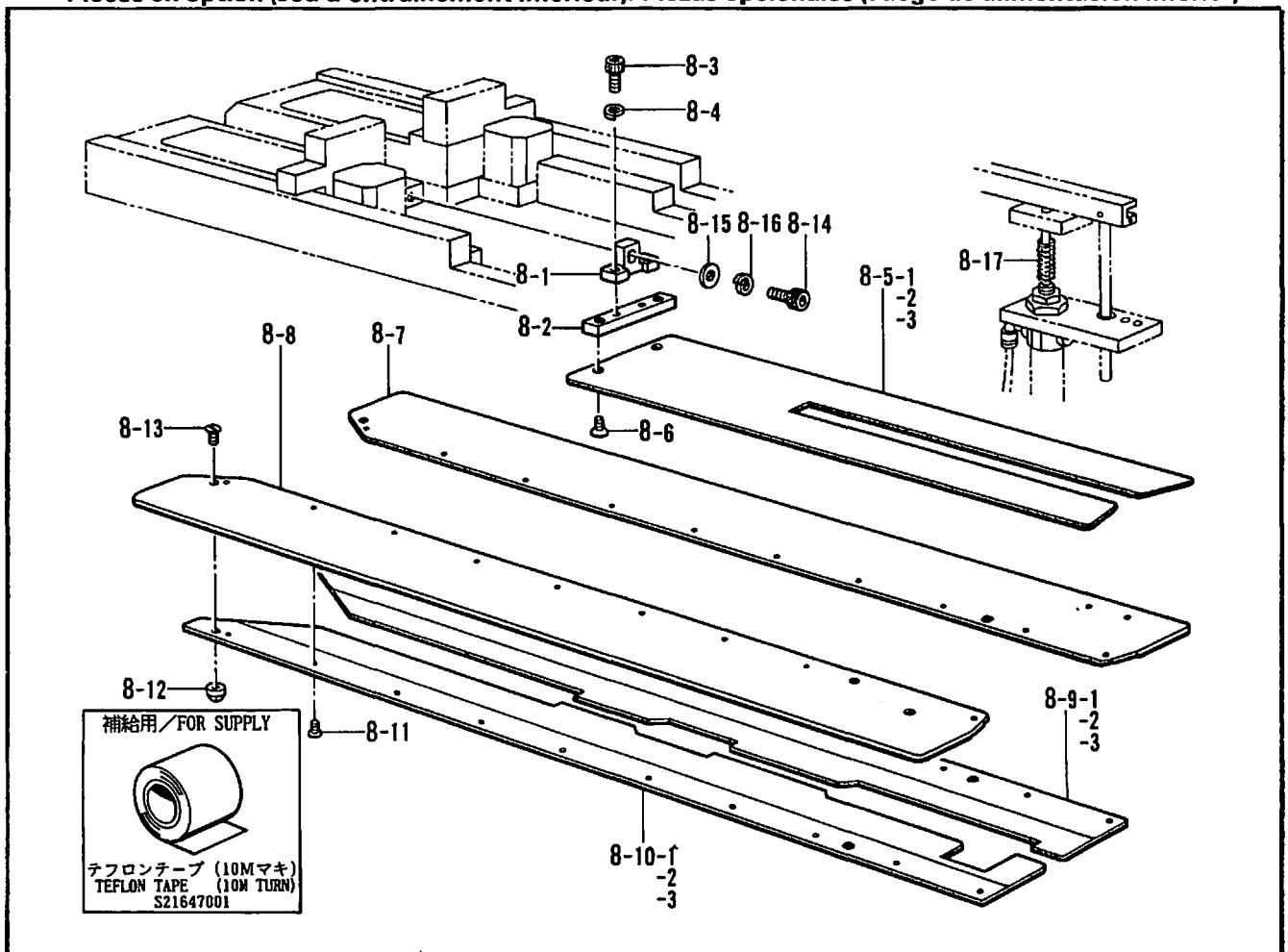

W3. 特別注文部品 (エアージェクター)/Option parts (Air ejector)/Sonderzubehör (Luftausstosser)/
Pièces en option (éjecteur d'air)/Piezas opcionales (eyector de aire)

REF.NO.	CODE	Q'TY	ヒンメイ	NAME OF PARTS	RMKS
7	S14155009	1	エアージ"エクター"クミ	AIR EJECTOR ASSY	
7-1	S14156009	1	イジ"エクタ"ダイ	EJECTOR BRACKET	
7-2	018082022	2	アナホ"ルト"8X20	BOLT 8X20	
7-3	025080232	2	ヒラサ"ガ"ネチユウ8	PLAIN WASHER 8	
7-4	028080242	2	ハ"ネサ"ガ"ネ2-8	SPRING WASHER 2-8	
7-5	S14091001	1	スタツカー"エア"ノズル	STACKER AIR NOZZLE	
7-6	014500522	2	アノメネシ"5クホ"ミ	SET SCREW 5	
7-7	S14157001	1	ハ"ルフ"ユニツトSAE	VALVE UNIT (SAE)	
7-7-1	S14158000	1	ハ"ルフ"VZ512	VALVE VZ512	
7-7-2	S14159000	2	エルホ"1/8-8	ELBOW 1/8-8	
7-7-3	140682001	1	サイレンサン	SILENCER	
7-8	062302505	2	ナヘ"ゴ3X25	SCREW 3X25	
7-9	028030243	2	ハ"ネサ"ガ"ネ2-3	SPRING WASHER 2-3	
7-10	025030233	2	ヒラサ"ガ"ネチユウ3	PLAIN WASHER 3	
7-11	S14160000	1	エルホ"	ELBOW	
7-12	S14161000	1	エア-ホ-ス8-C	AIR TUBE 8-C (L=160)	
7-13	S08361000	1	エア-ホ-ス8-B	AIR TUBE 8-B (L=1050)	

W4. 特別注文部品 (下送り装置)/Option parts (Bottom feed set)/Sonderzubehör (Untertransportsatz)/
Pièces en option (Jeu d'entraînement inférieur)/Piezas opcionales (Juego de alimentación inferior)

REF.NO.	CODE	Q'TY	ヒンメイ	NAME OF PARTS	RMKS
8	S21616001	1	シタオクリセット8-12MM	BOTTOM FEED SET (8-12MM)	
8	S21617001	1	シタオクリセット14-16MM	BOTTOM FEED SET (14-16MM)	
8	S21618001	1	シタオクリセット18-20MM	BOTTOM FEED SET (18-20MM)	
8-1	S21619001	1	オクリイタササエ	FEED PLATE SUPPORT	
8-2	S21620001	1	オクリイタ"ダイ"	FEED PLATE BASE	
8-3	018401022	2	アナホ"ルト"4X10	BOLT 4X10	
8-4	028040242	2	ハ"ネサ"ガ"ネ2-4	SPRING WASHER 2-4	
8-5-1	S21623000	1	オクリイタ8-12MM	FEED PLATE (8-12MM)	
8-5-2	S21624000	1	オクリイタ14-16MM	FEED PLATE (14-16MM)	
8-5-3	S21625000	1	オクリイタ18-20MM	FEED PLATE (18-20MM)	
8-6	003400804	2	サラネシ"4X8	SCREW 4X8	
8-7	S21621001	1	シタオクリイタ"カ"イト"R	BOTTOM FEED PLATE GUIDE (R)	
8-8	S21622001	1	シタオクリイタ"カ"イト"L	BOTTOM FEED PLATE GUIDE (L)	
8-9-1	S21686001	1	スヘ"リイタRクミ8-12	SLIDE PLATE (R) ASSY (8-12MM)	
8-9-2	S21688001	1	スヘ"リイタRクミ14-16	SLIDE PLATE (R) ASSY (14-16MM)	
8-9-3	S21690001	1	スヘ"リイタRクミ18-20	SLIDE PLATE (R) ASSY (18-20MM)	
8-10-1	S21687001	1	スヘ"リイタLクミ8-12	SLIDE PLATE (L) ASSY (8-12MM)	
8-10-2	S21689001	1	スヘ"リイタLクミ14-16	SLIDE PLATE (L) ASSY (14-16MM)	
8-10-3	S21691001	1	スヘ"リイタLクミ18-20	SLIDE PLATE (L) ASSY (18-20MM)	
8-11	100360003	20	サラネシ"2.38	SCREW 2.38	
8-12	S08197001	2	シデンピン	PIN	
8-13	004300602	2	プラスサラネシ"3X6	SCREW 3X6	
8-14	018501622	1	アナホ"ルト"5X16	BOLT 5X16	
8-15	025050232	1	ヒラサ"ガ"ネチユウ5	PLAIN WASHER 5	
8-16	028050242	1	ハ"ネサ"ガ"ネ2-5	SPRING WASHER 2-5	
8-17	S09685101	1	アツシユクハ"ネ	SPRING	

X. 踏板関係 (立ちペダル) / Foot switch pedal mechanism (Stand pedal) / Fußbetätigung (Standpedal) / Mécanisme de la pédale (Pédale à support) / Mecanismo del pedal (Pedal de soporte)

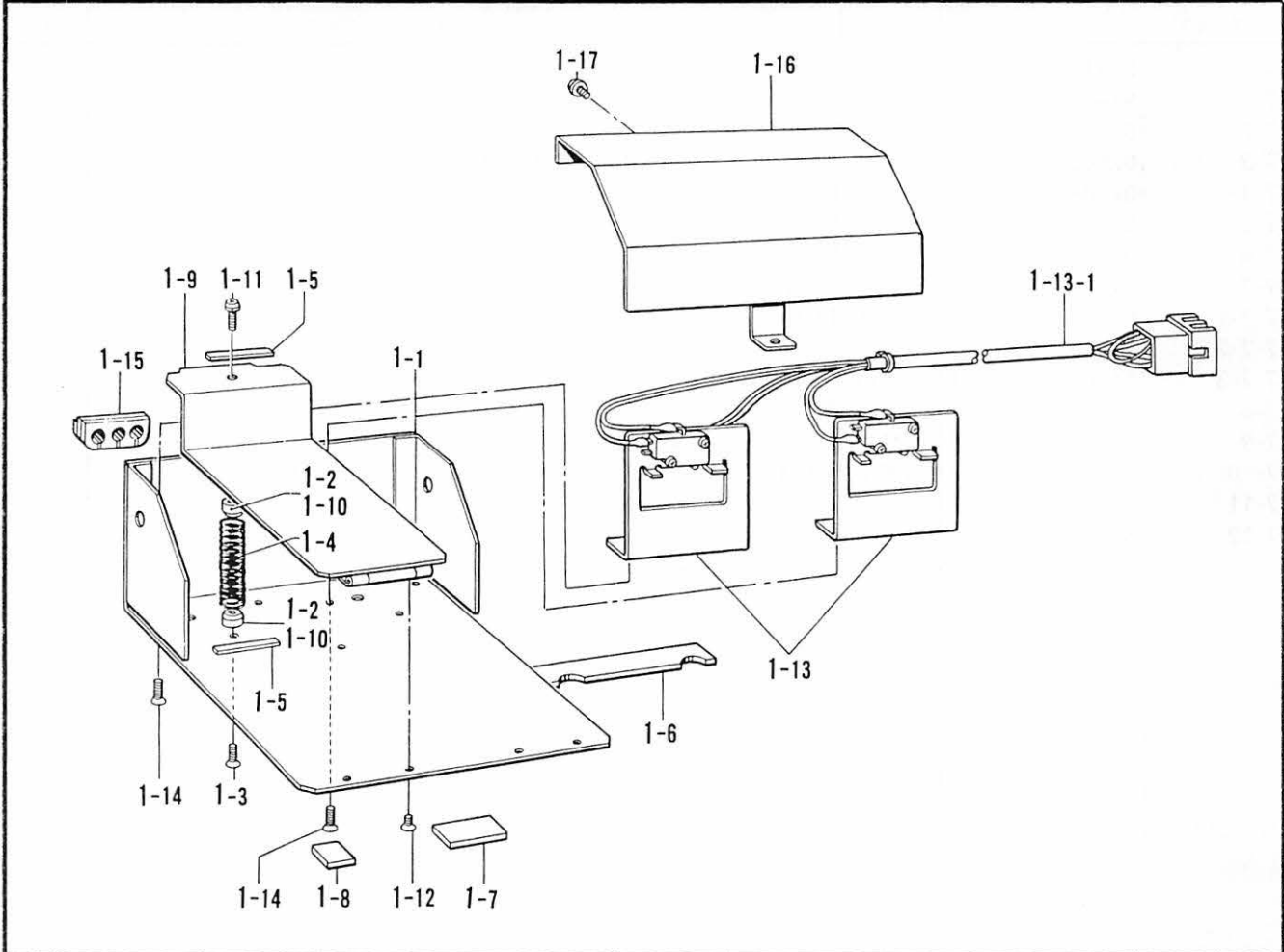

Z1. 付属品関係 (自動機付属) / Accessories (provided with automatic sewing machine) / Zubehör (mit automatischer Nähmaschine) / Accessoires (avec la machine à coudre automatique) / Accesorios (que vienen con la máquina de coser automática)

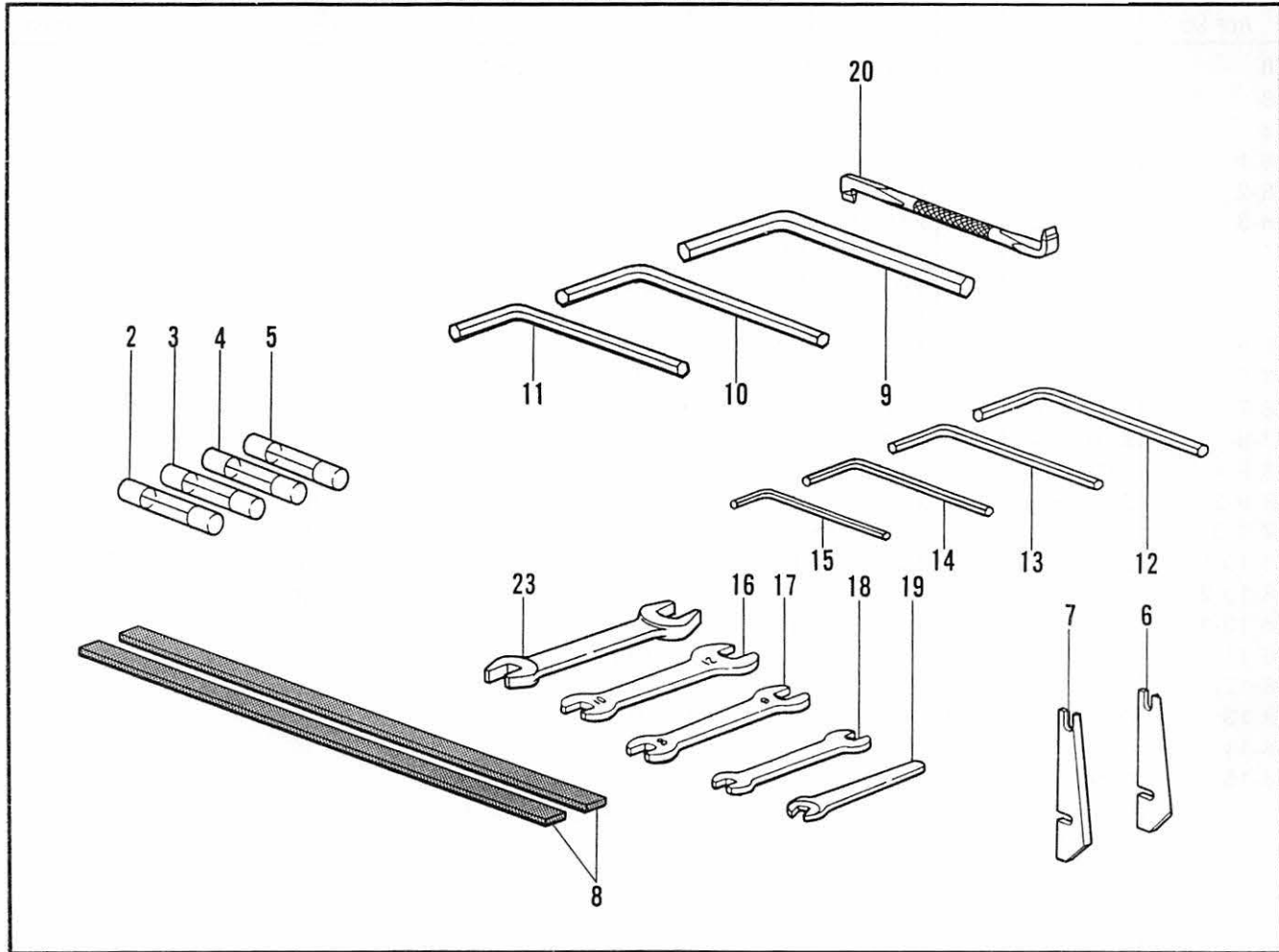

X. 踏板関係 (立ちペダル) / Foot switch pedal mechanism (Stand pedal) / Fußbetätigung (Standpedal) /
 Mécanisme de la pédale (Pédale à support) / Mecanismo del pedal (Pedal de soporte)

REF.NO.	CODE	Q'TY	ヒンメイ	NAME OF PARTS	RMKS
1	S18091001	1	タチペダルクミBAS600	STAND PEDAL ASSY	
1-1	S14817001	1	タチペダルベースクミ	STAND REDAL BASE ASSY	
1-2	233231001	2	ハネウケ#23	SPRING HOOK (#23)	
1-3	061401205	2	サコ4X12	SCREW 4X12	
1-4	233233001	2	オシハネ1.2X12X57	SPRING 1.2X12X57	
1-5	233232001	2	ゴムイタ1.6X5X45	RUBBER PLATE 1.6X5X45	
1-6	S14823001	1	ゴムイタ3.2X20X186	RUBBER PLATE 3.2X20X186	
1-7	233229001	1	ゴムイタ3.2X20X46	RUBBER PLATE 3.2X20X46	
1-8	233230001	2	ゴムイタ3.2X20X15	RUBBER PLATE 3.2X20X15	
1-9	233225001	2	ペダルクミ	PEDAL ASSY	
1-10	233231001	2	ハネウケ#23	SPRING HOOK (#23)	
1-11	217093001	2	ナハネセット4X12D	WASHER SCREW 4X12D	
1-12	061400402	4	サコ4X4	SCREW 4X4	
1-13	S18090001	1	M.SWクミ	MICRO SWITCH ASSY	
1-13-1	S18089001	1	M.SWコードクミ	MICRO SWITCH CORD ASSY	
1-14	061401205	4	サコ4X12	SCREW 4X12	
1-15	233250001	1	F.Pフツシンク	F.P BUSH	
1-16	S14821109	1	タチペダルカバークミ	STAND PEDAL COVER ASSY	
1-17	233236001	3	ナハネセット4X6DA	WASHER SCREW 4X6DA	

Z1. 付属品関係 (自動機付属) / Accessories (provided with automatic sewing machine) / Zubehör
 (mit automatischer Nähmaschine) / Accessoires (avec la machine à coudre automatique) /
 Accesorios (que vienen con la máquina de coser automática)

REF.NO.	CODE	Q'TY	ヒンメイ	NAME OF PARTS	RMKS
2	141032000	2	ヒューズ	FUSE (2A)	
3	S08030000	1	Gヒューズ5AFB	G FUSE (5AFB)	
4	153242000	1	ヒューズ6A	FUSE (6A)	
5	219225000	1	カンヒューズ8A	FUSE (8A)	
6	S08322001	2	コーナーメスSR	CORNER KNIFE (S-R)	
7	S08302001	2	コーナーメスSL	CORNER KNIFE (S-L)	
8	S08267003	2	オオオサエゴム	CARRIAGE FEED RUBBER	
9	115157001	1	6カクホウスハナ6	HEXAGONAL WRENCH 6	
10	150335001	1	6カクホウスハナ5	HEXAGONAL WRENCH 5	
11	118064001	1	6カクホウスハナ4	HEXAGONAL WRENCH 4	
12	142721001	1	6カクホウスハナ3	HEXAGONAL WRENCH 3	
13	154125001	1	6カクホウスハナ2.5	HEXAGONAL WRENCH 2.5	
14	142002001	1	6カクホウスハナ2	HEXAGONAL WRENCH 2	
15	S07783001	1	6カクホウスハナ1.5	HEXAGONAL WRENCH 1.5	
16	107780001	1	スパナ10X12	SPANNER 10X12	
17	100887001	1	スパナ8X9	SPANNER 8X9	
18	142205001	1	スパナ7X8	SPANNER 7X8	
19	S08132001	1	スパナ5.5	SPANNER 5.5	
20	S08170001	1	Zカクタネシマワシ	Z-STEEL SCREW DRIVER	
23	S14696001	1	スパナ11X13	SPANNER 11X13	

◎ 付属品の明細は変更することがあります。

◎ The details of included accessories are subject to change.

◎ Änderungen in der Aufstellung der Mitgelieferten Zubehöre sind vorbehalten.

◎ Les détails des accessoires inclus sont sujets à des changements.

◎ Los detalles de los accesorios incluidos pueden variar.

**Z2. 付属品関係 (頭部付属)/Accessories (provided with machine body)/Zubehör (mit Nähmaschine)/
Accessoires (avec le corps de la machine)/Accesorios (con el cuerpo de la máquina)**

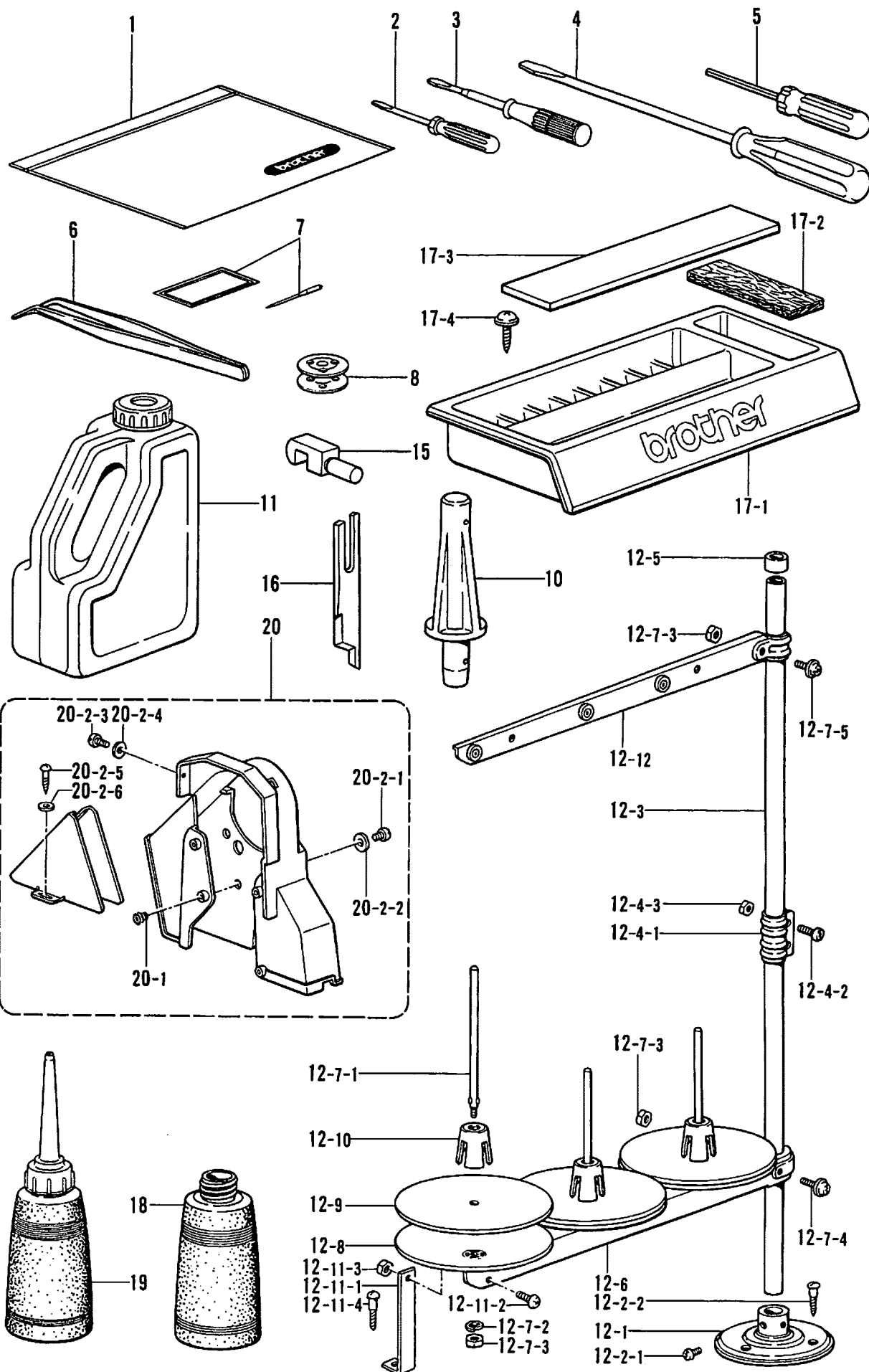

◎ 付属品の明細は変更することがあります。
 ◎ The details of included accessories are subject to change.
 ◎ Änderungen in der Aufstellung der Mitgelieferten Zubehöre sind vorbehalten.

◎ Les détails des accessoires inclus sont sujets à des changements.
 ◎ Los detalles de los accesorios incluidos pueden variar.

22. 付属品関係 (頭部付属)/Accessories (provided with machine body)/Zubehör (mit Nähmaschine)/
Accessoires (avec le corps de la machine)/Accesorios (con el cuerpo de la máquina)

REF.NO.	CODE	Q'TY	ヒンメイ	NAME OF PARTS	RMKS
1	122991001	1	フゾクヒンホリフクロ	ACCESSORY BAG	
2	142443001	1	ネジマワシ1.9X52	SCREW DRIVER 1.9X52	
3	118837001	1	ネジマワシ3.4X70	SCREW DRIVER 3.4X70	
4	101572101	1	ネジマワシ5.5X190	SCREW DRIVER 5.5X190	
5	S01943001	1	6カクホウネジマワシ1.6	SCREW DRIVER 1.6	
6	117466000	1	ピンセット	PINCETTE	
7	153011016	4	ミシンハリMTX190 #16	NEEDLE MTX190 (#16)	
8	S09285001	4	ホビン	BOBBIN	
10	159384009	1	トウフササエマクラ	HEAD REST	
11	154702001	1	オイルタンク	OIL TANK	
12	S02765109	1	イトタテダイクミ3	COTTON STAND ASSY 3	
12-1	150189109	1	ブラケット	BRACKET	
12-2	S02773001	1	ブラケットネジセット	COTTON STAND BASE SCREW SET	
12-2-1	062060806	2	ナヘコ6X8	SCREW 6X8	
12-2-2	031452206	3	マルモク45X22	SCREW 45X22	
12-3	150172003	2	コラムパイプ	COLUMN PIPE	
12-4	150106003	1	コラムジョイントクミ	COLUMN JOINT ASSY	
12-4-1	150173003	1	コラムジョイント	COLUMN JOINT	
12-4-2	062501406	2	ナヘコ5X14	SCREW 5X14	
12-4-3	021500106	2	1シユナツト5	NUT 5	
12-5	150174000	1	コラムキャップ	COLUMN CAP	
12-6	S02779009	1	スプールホルダー3	SPOOL HOLDER 3	
12-7	S02782001	1	スプールネジセット3	SPOOL SCREW SET 3	
12-7-1	150179002	3	スプールシクバ	SPOOL SHAFT (B)	
12-7-2	028050246	3	ハネサカネ2-5	SPRING WASHER 2-5	
12-7-3	021500106	5	1シユナツト5	NUT 5	
12-7-4	050503006	1	ナヘコヒラサ5X30	WASHER SCREW 5X30	
12-7-5	050501406	1	ナヘコヒラサ5X14	WASHER SCREW 5X14	
12-8	150180001	3	ウケサラ	SPOOL STAND BASE	
12-9	150182000	3	スプールのマット	SPOOL MAT	
12-10	126863001	3	スプールのクッション	SPOOL CUSHION	
12-11	S02784009	1	ホルダーササエAセット	HOLDER SUPPORT (A) SET	
12-11-1	150188009	1	スプールのホルダーササエA	SPOOL HOLDER SUPPORT (A)	
12-11-2	062501006	1	ナヘコ5X10	SCREW 5X10	
12-11-3	021500106	1	1シユナツト5	NUT 5	
12-11-4	031452206	1	マルモク45X22	SCREW 45X22	
12-12	S02788009	1	スレットハンガークミ3	THREAD HANGER ASSY 3	
15	141256001	2	トウフヒンジ	HEAD HINGE	
16	S16248101	1	ウフメスB	UPPER KNIFE (B)	
17	183400009	1	コモノケースセット	ACCESSORY CASE SET	
17-1	S02738009	1	コモノケース	ACCESSORY CASE	
17-2	S02740000	1	フェルト	FELT	
17-3	S02739000	1	ゴムシヤクテープ	RUBBER MAGNET TAPE	
17-4	039411215	2	1トラスタップピン4X12	TAPPING SCREW, TRUSS 1 M4X12	
18	114486002	1	ホリオイルライタイ	OILER	
19	114483002	1	ホリオイルラークミ	OILER ASSY	
20	183480009	1	ベルトカバークミ	BELT COVER ASSY	
20-1	S07660000	4	ゴムカラー	RUBBER COLLAR	
20-2-1	062712012	4	ナヘコ476-32X20	SCREW 476X20	
20-2-2	025050332	4	ヒラサカネタイ5	PLAIN WASHER 5	
20-2-3	062680812	1	ナヘコ437-40X8	SCREW 4.37X8	
20-2-4	025680232	1	ヒラサカネチユウ4.37	PLAIN WASHER 4.37	
20-2-5	100666002	2	マルモクネジ5.5X20	SCREW 5.5X20	
20-2-6	025750132	2	ヒラサカネチユウ5.56	PLAIN WASHER 5.56	

索引/INDEX/VERZEICHNIS/
INDEX/INDICE

CODE	REF.NO.	PAGE
S00208001	E - 42	6
S00402001	W1- 3-1	64
S00403100	V - 25	58
S00470000	P - 39	32
	V - 139	60
S00480000	J - 1-11	16
S00554000	Q - 8	34
S00603000	V - 112-4	60
S00614000	V - 112-2	60
S00617000	V - 116	60
S01522000	P - 15-5	32
S01542000	P - 19-5	32
S01698001	R2- 21	44
S01830000	U - 1-31	56
S01943001	Z2- 5	72
S02611001	J - 1-21-1	16
S02612001	J - 1-21-2	16
S02738009	Z2- 17-1	72
S02739000	Z2- 17-3	72
S02740000	Z2- 17-2	72
S02765109	Z2- 12	72
S02773001	Z2- 12-2	72
S02779009	Z2- 12-6	72
S02782001	Z2- 12-7	72
S02784009	Z2- 12-11	72
S02788009	Z2- 12-12	72
S03289001	G - 60	10
	G - 73	10
S03328000	V - 112-3	60
S03557001	R4- 26-18	52
S03566001	J - 1-18	16
S03820000	M - 1-15-2	28
S04411001	W2- 6-1-9	66
	W2- 6-2-9	66
S04557000	J - 1-24	16
	K1- 1-79	20
	K2- 2-29	22
	K2- 2-63	24
	P - 36	32
	Q - 20	34
	Q - 28	34
	V - 134	60
	W1- 4-4	64
	W2- 6-18	66
S04592000	M - 1-15-3	28
S04607009	W1- 4-1-2	64
S04891000	P - 7	32
S04897000	P - 15-6	32
	P - 19-6	32
S04905000	E - 50-2	6
S04910000	R1- 1-54-3	36
S06241000	S - 4	54
S06242001	S - 5	54
S06694001	U - 1-1-3	56
S06736009	K2- 2-5	22
S06737000	K2- 2-6	22
S06739009	K2- 2-11	22
S06740001	K2- 2-15	22
S06741001	K2- 2-16	22
S06744000	K2- 2-25	22
S06857000	P - 8	32
S06858000	P - 8-1	32
S06859000	P - 8-2	32
S06866000	R1- 1-54-2	36
S06882000	M - 9-4-2	28
	R3- 25-52-2	46
	R3- 25-55-3	48

CODE	REF.NO.	PAGE
S06883000	R3- 25-52-3	46
	R3- 25-55-2	48
S06886000	K2- 2-26-1-2	22
	R1- 1-88-2	38
S06890000	R4- 26-2-2	52
	R4- 35-2	50
	W2- 6-1-6-2	66
	W2- 6-2-6-2	66
S06897000	K2- 2-26-1-1	22
S06898000	R2- 12-15-2	42
S07026001	V - 69	58
S07330101	B - 3	2
S07334001	B - 22	2
S07338001	B - 24	2
S07339009	B - 26	2
S07340009	B - 19	2
S07417001	F - 9	8
S07419001	F - 8	8
S07420000	F - 7	8
S07423101	F - 19	8
S07424001	F - 20	8
S07430001	F - 28	8
S07431001	F - 30	8
S07432001	F - 38	8
S07433001	F - 39	8
S07434001	F - 34	8
S07435001	F - 36	8
S07436001	F - 24	8
S07437001	F - 25	8
S07439001	D - 4	4
S07442001	D - 7	4
S07446001	D - 6	4
S07447001	D - 6-1	4
S07448001	G - 1	10
S07449000	G - 2	10
S07450109	G - 24	10
S07453000	G - 47	10
S07455100	G - 49	10
S07456000	G - 50	10
S07457100	G - 51	10
S07458100	G - 53	10
S07459100	G - 54	10
S07460100	G - 46	10
S07461000	G - 63	10
S07462000	G - 69	10
S07463000	G - 70	10
S07464100	G - 74	10
S07465000	G - 55	10
S07467001	G - 78	10
S07468000	G - 80	10
S07469001	G - 81	10
S07471001	G - 22	10
S07473000	G - 86	12
S07474000	G - 34	10
S07476000	G - 36	10
S07477000	G - 4	10
S07478000	G - 5	10
S07479101	G - 6	10
S07481009	G - 87	12
S07487001	H - 1-6	14
S07488001	H - 1-10	14
S07489109	H - 1	14
S07490001	H - 1-13	14
S07571000	G - 39	10
S07658001	F - 27	8
S07660000	Z2- 20-1	72
S07783001	Z1- 15	70

CODE	REF.NO.	PAGE
S07810000	G - 52	10
S07876001	G - 88	12
	G - 98	12
	G - 99	12
S08007000	K1- 1-80-3	20
	K2- 2-64-1	24
S08009000	R2- 17-2	44
S08017000	K1- 1-80-4	20
	K2- 2-64-2	24
	R2- 17-1-1	44
S08030000	N - 1-1-5	30
	Z1 - 3	70
S08032000	N - 1-1-1	30
S08086000	Q - 9-1	34
S08089001	V - 112	60
S08105000	Q - 10	34
S08109000	Q - 13	34
S08110000	Q - 14	34
S08113000	Q - 19	34
S08114009	Q - 15	34
S08115000	Q - 16	34
S08116000	Q - 17	34
S08117000	J - 1-8	16
S08125000	K2- 2-27	22
S08126000	K2- 2-28	22
S08127001	K1- 1-80	20
S08130000	K2- 2-64	24
S08131000	K1- 1-80-1	20
S08132001	Z1 - 19	70
S08134000	K2- 3	24
S08135001	K1- 1-72	20
	K2- 2-57	24
S08136000	P - 12	32
S08137000	R2- 24	44
S08138000	K1- 1-75	20
S08139000	K1- 1-76	20
	K2- 2-60	24
S08140000	K1- 1-77	20
	K2- 2-61	24
S08142001	R3- 25-45	46
S08143000	P - 9	32
S08144000	P - 10	32
S08145000	P - 11	32
S08146000	P - 13	32
	W2- 6-16	66
S08147000	P - 14	32
S08148001	R3- 25-72	48
S08149001	R3- 25-62	48
S08151000	K1- 1-72-1	20
	K2- 2-57-1	24
	P - 19-1	32
S08152000	K1- 1-72-5	20
	K2- 2-57-5	24
S08154000	K1- 1-72-2	20
	K2- 2-57-2	24
S08155000	P - 15-2	32
	P - 19-2	32
S08159001	P - 19	32
S08163000	P - 22	32
S08164000	P - 23	32
S08165000	P - 24	32
S08166000	P - 25	32
S08167000	P - 26	32
S08168000	P - 27	32
S08169000	P - 28	32
S08170001	Z1 - 20	70
S08171000	P - 29	32

CODE	REF.NO.	PAGE
S08172000	P - 30	32
	W2- 6-14	66
S08173000	P - 31	32
S08174000	P - 32	32
S08175000	P - 33	32
S08176000	P - 34	32
S08177000	P - 35	32
S08178000	P - 16	32
	W2- 6-13	66
S08180000	R1- 1-67	38
S08185009	V - 9	58
S08186009	V - 10	58
S08191001	V - 23	58
S08192009	V - 91	60
S08194001	V - 29	58
S08197001	V - 67	58
	W4- 8-12	68
S08200001	V - 59	58
S08201001	V - 64	58
S08205000	V - 54	58
S08206009	V - 73	60
S08207001	R3- 25-61	48
S08208001	R4- 38	50
S08211001	R4- 29-1	50
S08213001	R4- 29-2	50
S08214009	R4- 33	50
S08215009	R4- 29-6	50
S08216001	R3- 25-66	48
S08220001	V - 125	60
S08221009	V - 80	60
S08222009	V - 82-1	60
S08224001	V - 97	60
S08225001	V - 98	60
S08228001	R3- 25-1	46
S08229001	R3- 25-5	46
S08230001	R3- 25-9	46
S08231000	R3- 25-11	46
S08232000	R3- 25-12	46
S08233000	R3- 25-16	46
S08234001	R3- 25-29	46
S08237001	R3- 25-34	46
S08238000	R2- 12-25	42
	R2- 12-4	42
	R3- 25-35	46
S08239000	R2- 12-5	42
	R3- 25-36	46
S08240000	R2- 12-26	42
	R2- 12-6	42
	R3- 25-37	46
S08241001	R3- 25-39	46
S08242000	R3- 25-42	46
S08243000	R4- 29-3-1	50
S08245001	R3- 25-18	46
S08246001	R3- 25-19	46
S08247001	R3- 25-25	46
S08248001	R3- 25-22	46
S08249000	R3- 25-47	46
S08250000	R3- 25-52	46
S08251000	R3- 25-52-1	46
S08252000	R3- 25-42-1	46
S08253000	R3- 25-56	48
S08254001	R3- 25-68	48
S08255001	R3- 25-69	48
S08256001	R3- 25-63	48
S08257001	R3- 25-77	48
S08258101	R3- 25-79	48
S08259101	R3- 25-80	48

CODE	REF.NO.	PAGE
S08260001	R3 - 25-82	48
S08261001	R3 - 25-83	48
S08264001	R3 - 25-86	48
S08266001	R4 - 73	52
S08267003	W2- 6-17	66
	Z1 - 8	70
S08268001	R4 - 26-1	52
S08270001	V - 32	58
S08271000	R4 - 26-2	52
S08272000	R4 - 26-2-1	52
S08273001	R4 - 26-5	52
S08275001	R4 - 26-9	52
S08276001	R4 - 26-10	52
S08279000	R4 - 26-17	52
S08280000	R1 - 1-9	36
S08284001	R1 - 1-1	36
S08285001	R1 - 2	38
S08286000	R1 - 1-2	36
S08287000	R1 - 8	38
S08288000	R1 - 11	38
S08289001	R1 - 1-3	36
S08290001	R1 - 1-5	36
S08291001	R1 - 1-6	36
S08292000	R1 - 1-7	36
S08293001	R1 - 1-10	36
S08294001	R1 - 1-12	36
S08295100	R1 - 1-16	36
S08296001	R1 - 1-79	38
S08297001	R1 - 1-78	38
S08300001	R1 - 1-36	36
S08301001	R1 - 1-26	36
S08302001	Z1 - 7	70
S08303001	R1 - 1-64	38
S08304001	R1 - 1-30	36
S08306000	R1 - 1-32	36
S08308001	R1 - 1-65	38
S08315000	R1 - 1-93	38
S08317001	R1 - 1-44	36
S08318001	R1 - 1-47	36
S08320001	R1 - 1-52	36
S08322001	Z1 - 6	70
S08323000	R1 - 1-54	36
S08324000	R1 - 1-54-1	36
S08325001	R1 - 1-55	36
S08326000	R1 - 1-56	36
	R3 - 25-58	48
S08327001	R1 - 1-57	38
S08328001	R1 - 1-59	38
S08329001	R1 - 1-63	38
S08332000	R2 - 12-3	42
	R3 - 25-33	46
S08333001	R2 - 12-8	42
S08335000	R2 - 12-15	42
S08336000	R2 - 12-15-1	42
S08338001	R2 - 12-21	42
S08339001	R2 - 12-22	42
S08341009	R2 - 12-20	42
S08342001	R2 - 12-7	42
S08343000	R2 - 12-29	42
S08347009	R2 - 12-39	42
S08352000	K2 - 2-26-2	22
	R2 - 12-16	42
S08360001	R2 - 12-10	42
S08361000	K1 - 1-78	20
	K2 - 2-62	24
	W3- 7-13	68
S08363001	K1 - 1-1	18

CODE	REF.NO.	PAGE
S08367000	R2 - 17-1	44
S08368001	V - 30	58
S08372001	R2 - 12-67	44
S08377001	M - 9-2	28
S08381001	M - 9-8	28
S08382001	M - 9-9	28
S08383001	M - 9-12	28
S08384001	M - 9-14	28
S08386001	M - 9-16	28
S08387000	M - 9-4	28
S08388000	M - 9-4-1	28
S08397000	M - 1-2	28
S08398009	K1 - 1-52	18
S08400000	R1 - 1-21	36
S08407000	M - 1-15-1	28
S08408000	E - 53	6
S08411001	U - 1-8	56
S08412001	U - 1-8-1	56
S08413001	U - 1-10	56
S08416000	U - 1-11	56
S08417000	U - 1-12	56
S08418000	U - 1-14	56
S08419001	U - 1-16	56
S08420000	U - 1-17	56
S08421000	U - 1-19	56
S08422000	U - 1-20	56
S08423001	U - 1-21	56
S08424001	U - 1-25	56
S08426009	U - 1-29	56
S08427101	V - 93	60
S08431209	K1 - 1	18
S08432001	K1 - 1-1-1	18
S08433000	K1 - 1-1-2	18
S08434001	K1 - 1-4	18
S08435001	K1 - 1-5	18
S08436001	K1 - 1-7	18
S08437001	K1 - 1-8	18
S08438001	K1 - 1-11	18
S08439001	K1 - 1-12	18
S08440000	K1 - 1-13	18
S08441001	K1 - 1-14	18
S08442001	K1 - 1-15	18
S08443001	K1 - 1-18	18
S08444000	K1 - 1-20	18
S08445001	K1 - 1-21	18
S08446000	K1 - 1-22	18
S08447000	K1 - 1-22-1	18
S08448001	K1 - 1-23	18
S08449009	K1 - 1-37	18
S08450009	K1 - 1-27	18
S08458009	K1 - 1-52-1	18
S08459000	K1 - 1-52-2	18
	K1 - 1-56	20
S08460001	K1 - 1-57	20
S08470009	K1 - 1-64	20
S08471009	K1 - 1-68	20
S08488000	R1 - 1-54-4	36
S08489000	R3 - 25-55-1	48
S08493000	R3 - 25-55	48
S08498000	R3 - 25-42-2	46
	R4 - 29-3-2	50
S08499000	R4 - 29-3	50
S08501000	R1 - 1-54-5	36
S08502000	R2 - 17	44
S08507000	R3 - 25-57	48
S08509001	R1 - 1-66	38
	R1 - 1-95	38

CODE	REF.NO.	PAGE
S08509001	R3- 25-67	48
	R4- 26-19	52
S08514001	K1- 1-35	18
	K2- 2-38	22
S09132001	C - 5	4
S09141000	P - 43	32
	V - 137	60
S09142000	V - 138	60
S09153001	R1- 1-74	38
S09155000	R1- 1-69	38
S09156000	R1- 1-69-1	38
S09157000	R1- 1-20	36
S09170000	R1- 1-96	38
S09174000	R4- 35	50
S09175000	R4- 35-1	50
S09252001	B - 21	2
S09255201	F - 1	8
S09259001	F - 5	8
S09260001	F - 6-1	8
S09261001	F - 6-2	8
S09262101	F - 15	8
S09264001	F - 23	8
S09268001	F - 23-1-1	8
S09273001	F - 23-1-2	8
S09278001	F - 23-2	8
S09284001	F - 23-2-4	8
S09285001	F - 41	8
	Z2- 8	72
S09287000	D - 1	4
S09288000	D - 2	4
S09364000	G - 94	12
S09369000	G - 93	12
S09399009	J - 1	16
S09400009	J - 1-1	16
S09401001	J - 1-2	16
S09402101	J - 1-6	16
S09403009	J - 1-14	16
S09406000	K1- 1-38	18
	K2- 2-41	22
S09407000	K1- 1-38-1	18
	K2- 2-41-1	22
S09446001	R4- 26-20	52
S09447009	R4- 29	50
S09448000	V - 147	62
	V - 15	58
S09449001	V - 63	58
S09450001	V - 99	60
S09618001	K1- 1-43	18
	K2- 2-52	22
S09619001	K1- 1-44	18
	K2- 2-55	22
S09670001	B - 20	2
S09685101	R1- 1-97	38
	W4- 8-17	68
S09687009	W1- 2-1	64
S09690001	V - 74	60
S10167000	G - 72	10
S10268001	W2- 6-1-5	66
	W2- 6-2-5	66
S10315000	N - 1-1-2	30
S10540000	R1- 10	38
S10551001	R4- 26-3	52
S10557000	P - 44	32
S10559009	V - 82	60
S10588001	E - 46	6
S11083000	W1- 5-1-1	64
S11084001	W1- 5-2	64

CODE	REF.NO.	PAGE
S11148001	W1- 3	64
S11334001	W1- 4-1	64
S11335009	W1- 4-1-1	64
S11336009	W1- 4-1-7	64
S11337000	Q - 23	34
S11338000	Q - 40	34
S11426000	W2- 6-7-3	66
S11502009	W1- 2	64
S11503009	W1- 4	64
S11504001	W1- 5	64
S11505000	W1- 5-1	64
S11506000	W1- 5-1-2	64
S11685000	K2- 2-26-1	22
S12445001	D - 5	4
S12642001	W2- 6-1-7	66
	W2- 6-2-7	66
S13021001	F - 16	8
S13084001	R3- 25-93	48
S13570001	W2- 6-1-1	66
S13571001	W2- 6-2-1	66
S13572001	W2- 6-1-2	66
S13573001	W2- 6-2-2	66
S13574000	W2- 6-1-6	66
	W2- 6-2-6	66
S13575000	W2- 6-1-6-1	66
	W2- 6-2-6-1	66
S13576100	W2- 6-1-3	66
	W2- 6-2-3	66
S13577000	W2- 6-7	66
S13578000	W2- 6-7-1	66
S13579001	W2- 6-10	66
S13615001	F - 23-1	8
S13638001	R1- 1-85	38
S13639000	R1- 1-88	38
S13640000	R1- 1-88-1	38
S13641001	R1- 1-90	38
S14050001	T - 4-1	54
S14051001	T - 4-2	54
S14062001	W2- 6-6	66
S14063001	W2- 6-5	66
S14091001	W3- 7-5	68
S14118000	Q - 24	34
S14145000	W2- 6-7-2	66
S14146000	W2- 6-15	66
S14155009	W3- 7	68
S14156009	W3- 7-1	68
S14157001	W3- 7-7	68
S14158000	W3- 7-7-1	68
S14159000	W3- 7-7-2	68
S14160000	W3- 7-11	68
S14161000	W3- 7-12	68
S14189000	G - 100	12
S14197000	U - 1-28	56
S14412000	Q - 1	34
S14414001	Q - 18	34
S14640009	A - 2	2
S14642001	E - 2	6
S14643001	E - 11	6
S14647001	E - 14	6
S14649001	E - 15	6
S14650001	E - 16	6
S14651001	E - 17	6
S14652001	E - 21-3	6
S14653001	E - 25	6
S14654001	E - 26	6
S14655001	E - 28	6
S14656001	E - 30	6

CODE	REF.NO.	PAGE
S14657001	E - 32	6
S14658001	E - 34	6
S14659001	E - 41	6
S14660101	E - 43	6
S14661009	E - 45	6
S14665000	E - 50	6
S14666000	E - 50-1	6
S14667001	E - 51	6
S14668001	B - 5	2
S14674001	E - 3	6
S14675001	S - 6	54
S14677001	H - 5	14
S14685001	G - 127	12
S14689001	M - 1-1	28
S14690001	M - 1-12	28
S14691009	M - 1-14	28
S14692001	M - 9-1	28
S14693001	M - 9-5	28
S14694001	M - 9-6	28
S14696001	Z1 - 23	70
S14703001	R2- 12-65	44
S14704200	R2- 12-69	44
S14705000	R2- 12-69-1	44
S14753001	R1 - 45	38
S14754001	R1 - 1-51	36
S14796101	V - 44	58
S14797001	V - 49	58
S14798001	V - 50	58
S14799001	R1 - 1-31	36
S14802001	M - 1-9	28
S14817001	X - 1-1	70
S14821109	X - 1-16	70
S14823001	X - 1-6	70
S15061009	K1 - 1-48	18
S15062009	K1 - 1-59	20
	K2 - 2-47	22
S15063009	K2 - 2-1	22
S15065009	K2 - 2-30	22
S15066009	K2 - 2-40	22
S15068101	F - 2	8
S15076101	P - 15	32
S15077000	P - 15-1	32
S15096000	H - 12	14
S15097000	H - 12-1	14
S15201001	R1 - 1-70	38
S15202001	R1 - 1-98	38
S15203000	R1 - 40	38
S15580001	C - 1	4
S15590001	R1 - 1-82	38
S15591001	R1 - 1-92	38
S15602009	T - 5	54
S15604009	T - 5	54
S15606009	T - 5	54
S15673001	V - 89	60
S15815001	R2- 12-1	42
S15871000	H - 12-2	14
S15890001	W2- 6	66
S15891001	W2- 6-1	66
S15892001	W2- 6-2	66
S16114001	G - 7	10
S16147001	M - 9	28
S16162000	P - 1	32
S16198000	Q - 9-2	34
S16248101	E - 36	6
	Z2 - 16	72
S16255001	V - 121	60
S16667000	L - 1-27-1	26

CODE	REF.NO.	PAGE
S16669000	L - 1-32	26
S16887001	R3- 25-38	46
S18087001	G - 129	12
S18089001	X - 1-13-1	70
S18090001	X - 1-13	70
S18091001	X - 1	70
S18385000	G - 133	12
S18707141	V - 119	60
S18894000	R2- 17-1	44
S18895000	R2- 17-1	44
S18940000	R2- 17	44
S18941000	R2- 17	44
S18942000	Q - 42	34
S19900000	R2- 12-69-2	44
S21006001	R2- 12-40	42
S21008001	R2- 12-46	42
S21009001	R2- 12-48	42
S21181000	Q - 11	34
S21195001	G - 82	12
S21196001	G - 134	12
S21203001	L - 1-27	26
S21224000	R1 - 1-35	36
S21225000	R1 - 1-34	36
S21407001	R1 - 1-40	36
S21616001	W4- 8	68
S21617001	W4- 8	68
S21618001	W4- 8	68
S21619001	W4- 8-1	68
S21620001	W4- 8-2	68
S21621001	W4- 8-7	68
S21622001	W4- 8-8	68
S21623000	W4- 8-5-1	68
S21624000	W4- 8-5-2	68
S21625000	W4- 8-5-3	68
S21686001	W4- 8-9-1	68
S21687001	W4- 8-10-1	68
S21688001	W4- 8-9-2	68
S21689001	W4- 8-10-2	68
S21690001	W4- 8-9-3	68
S21691001	W4- 8-10-3	68
S24033001	R3 - 25-94	48
S29008001	Q - 3	34
S29133000	R2- 82-1	44
S29707000	K1 - 1-22-2	18
	K1 - 1-38-2	18
	K2 - 2-41-2	22
S29863001	C - 1-6	4
S29936001	W1- 9	64
S29937001	W1- 9-1	64
S29938001	W1- 9-2	64
S29939001	W1- 9-3	64
S29940001	W1- 9-4	64
S29941001	W1- 9-5	64
S29942001	W1- 9-6	64
S29943001	W1- 9-7	64
S29944001	W1- 9-8	64
S30014001	R2 - 12-49	42
S30038001	R2 - 82	44
S30040000	W1- 11	64
S30085000	N - 6-1	30
S30206000	Q - 3-1	34
S30224000	N - 1-1-3	30
S30227000	N - 1-1-4	30
S30505001	H - 13	14
S30570001	C - 1-2	4
S31204009	M - 1	28
S31205000	M - 1-15	28

CODE	REF.NO.	PAGE
S31206009	N - 6	30
S31215000	Q - 7	34
S31216000	Q - 5	34
S31217000	Q - 6	34
S31218000	Q - 12	34
S31226009	V - 8	58
S31227009	V - 12	58
S31228009	V - 19	58
S31233001	R3- 25-31	46
S31237001	R3- 25-32	46
S31617001	R2- 12-43	42
S31618001	R2- 12-50	42
S31619000	R2- 12-55	42
S31620000	R2- 12-56	42
S31621009	V - 2	58
S31622009	V - 13	58
S31623001	V - 36	58
S31729001	V - 120	60
S31740001	N - 1	30
S31755000	N - 2	30
S31760000	V - 157	62
S31814001	K2- 2-7	22
S31884000	Q - 2	34
S31889000	Q - 4	34
S31912001	N - 1-1	30
S31914001	R3- 62-1	48
S31915001	R3- 63-1	48
S31916001	R4- 62-2	52
S31917001	R4- 63-2	52
S31918001	R2- 12-2	42
S31919000	Q - 25	34
S31920001	R3- 25-75	48
S31921000	R2- 12-24	42
S31922001	R4- 78	52
S31923001	R4- 76	52
S31924001	R4- 26-12	52
S31925001	R4- 26-13	52
S31926001	R2- 12-35	42
S31927001	R2- 12-27	42
S31928001	R2- 12-32	42
S31929001	R2- 12-61	44
S31930000	Q - 26	34
S31931000	Q - 27	34
S31948001	R2- 12-51	42
S31949001	R3- 25	46
S31991001	R3- 25-90	48
S32010001	R1- 1	36
S32011001	R2- 12	42
S32012009	U - 1	56
S32018001	R4- 26	52
S33250001	K2- 2-10	22
S33260009	K2- 2	22
0A5501006	N - 3	30
002301003	W2- 6-8	66
002301203	V - 104	60
002402502	K1- 1-81	20
003400804	W4- 8-6	68
004300513	L - 1-3	26
	R3- 64	48
	R4- 29-7	50
	R4- 64	52
	V - 68	58
004300602	W4- 8-13	68
004301003	V - 75	60
004401003	R3- 25-92	48
	R4- 34	50
	V - 135	60

CODE	REF.NO.	PAGE
008300604	V - 90	60
	V - 94	60
008400604	U - 1-30	56
	V - 11	58
	V - 122	60
	V - 14	58
	V - 156	62
	W1- 2-2	64
012060636	K1- 1-36	18
	K2- 2-39	22
	R2- 12-23	42
012300336	R1- 43	38
	R2- 12-68	44
012400436	R1- 46	40
	R2- 12-47	42
012400836	U - 1-13	56
012500536	K1- 1-63	20
	K2- 2-21	22
	K2- 2-51	22
	R3- 25-26	46
	R3- 25-30	46
	R3- 25-78	48
013710512	F - 10	8
013711012	F - 17	8
013719412	A - 8	2
013780710	C - 4	4
013781012	B - 2	2
	B - 23	2
	E - 10	6
	E - 18	6
	E - 27	6
	E - 29	6
	E - 8	6
014060622	R1- 1-11	36
	R1- 1-4	36
014300332	L - 1-6	26
014400422	M - 9-3	28
	R1- 1-53	36
014400522	R4- 26-11	52
014500522	J - 1-22	16
	R1- 1-58	38
	R1- 1-80	38
	W3- 7-6	68
014501222	R1- 9	38
014680422	L - 1-9	26
014680622	F - 33	8
	F - 37	8
014760622	V - 114	60
014771022	B - 15	2
	D - 6-4	4
	D - 8	4
014780622	B - 4	2
	D - 3	4
016771032	B - 16	2
017062503	V - 115	60
017082203	V - 70	58
018061236	P - 2	32
018061622	R1- 1-71	38
018061636	K1- 1-65	20
	V - 55	58
018062022	R1- 1-89	38
018062036	R2- 12-36	42
	R3- 25-48	46
	V - 37	58
	V - 45	58
018062522	R1- 1-17	36
	R1- 3	38

CODE	REF.NO.	PAGE
018062536	K1 - 1-60	20
	K2 - 2-48	22
	R1 - 70	40
018063022	C - 5-1	4
018081236	K1 - 1-32	18
	K2 - 2-17	22
	K2 - 2-35	22
018082022	W3- 7-2	68
018082036	K1 - 1-28	18
	K1 - 1-49	18
	K2 - 2-2	22
018082536	K2 - 2-31	22
	U - 1-5	56
	K2 - 2-12	22
	R2 - 12-17	42
	R3 - 25-13	46
018083036	V - 48	58
	R3 - 25-2	46
	R3 - 25-6	46
018300622	M - 9-13	28
	M - 9-15	28
018300822	R1 - 1-27	36
018300836	M - 1-10	28
	M - 1-3	28
	M - 1-6	28
018301236	R4 - 79	52
	R4 - 80	52
	R2 - 12-41	42
018301636	R2 - 12-44	42
	R2 - 12-52	42
	R2 - 12-53	42
018400622	W1- 4-1-8	64
018400822	W2- 6-3	66
018400836	R3 - 25-73	48
018401022	W4- 8-3	68
018401036	K1 - 1-2	18
	M - 3	28
	R3 - 25-10	46
018401222	R3 - 25-76	48
	M - 9-7	28
	R1 - 1-13	36
018401236	R1 - 47	40
	R2 - 12-28	42
	R3 - 25-59	48
018401422	U - 1-22	56
	V - 100	60
	R4 - 26-14	52
018401622	R1 - 1-86	38
018401636	R3 - 25-70	48
	U - 1-32	56
	V - 51	58
	V - 6	58
	V - 65	58
018402536	R1 - 41	38
	R3 - 25-53	46
	R4 - 29-4	50
018403036	V - 101	60
	M - 2	28
	R4 - 27	52
018500836	V - 33	58
018501036	K1 - 1-69	20
018501236	R3 - 25-17	46
	R2 - 12-58	42
	V - 20	58
018501422	R1 - 1-83	38
018501436	R2 - 12-33	42
	R3 - 25-20	46

CODE	REF.NO.	PAGE
018501436	V - 3	58
018501622	M - 10	28
	R1 - 1-41	36
	R1 - 1-60	38
018501636	R1 - 6	38
	W4- 8-14	68
	K1 - 1-24	18
	K1 - 1-46	18
	K2 - 2-53	22
018502022	R2 - 12-37	42
	R2 - 12-62	44
	R3 - 25-81	48
	R4 - 30	50
	R1 - 1-48	36
018502036	R1 - 1-75	38
	K1 - 1-16	18
	R2 - 18	44
018502536	R3 - 25-27	46
	R3 - 25-40	46
	R3 - 25-23	46
018503022	R1 - 1-45	36
018503036	K1 - 1-73	20
	K2 - 2-58	24
	P - 17	32
018504522	P - 20	32
	R2 - 82-2	44
	V - 58	58
021060102	U - 1-1-4	56
021060106	U - 1-33	56
	U - 1-8-2	56
	R3 - 25-51	46
021060206	R3 - 25-64	48
	V - 62	58
	K1 - 1-9	18
021080206	R1 - 1-68	38
	R2 - 12-11	42
	R2 - 12-9	42
021120304	V - 26	58
021200203	W1- 3-2	64
021300103	J - 1-5	16
	V - 151	62
	V - 78	60
021300303	R2 - 12-45	42
	R2 - 12-54	42
	L - 1-26	26
021400103	W1- 2-3	64
	W1- 5-3	64
	J - 1-20	16
021400202	R4 - 26-8	52
	R4 - 29-9	50
	R3 - 25-28	46
021500103	R4 - 77	52
	Z2 - 12-11-3	72
	Z2 - 12-4-3	72
021500106	Z2 - 12-7-3	72
	H - 1-20	14
	M - 1-4	28
021670102	M - 1-7	28
025030133	R4 - 75	52
	R1 - 1-29	36
	J - 1-16	16
025030232	J - 1-3	16
	L - 1-30	26
	R1 - 1-25	36
025030233	R1 - 1-39	36
	R3 - 25-88	48
	V - 105	60

CODE	REF.NO.	PAGE	
025030233	V - 149	62	
	W1- 4-1-6	64	
	W3- 7-10	68	
025030236	V - 17	58	
	V - 76	60	
025040132	R4- 26-16	52	
025040232	R1- 1-15	36	
025040233	J - 1-13	16	
	L - 1-23	26	
	P - 42	32	
	V - 143	60	
	V - 143	60	
025040236	M - 4	28	
	R1- 1-22	36	
	R1- 49	40	
	R4- 29-8	50	
	U - 1-23	56	
	V - 102	60	
	V - 7	58	
	R1- 1-43	36	
	R1- 1-50	36	
	R1- 1-62	38	
025050232	R1- 1-77	38	
	W4- 8-15	68	
	K1- 1-26	18	
	K1- 1-71	20	
	K2- 2-8	22	
	R2- 12-31	42	
	R2- 12-63	44	
	R2- 19	44	
	R4- 31	50	
	V - 21	58	
025050236	V - 35	58	
	V - 4	58	
	Z2 - 20-2-2	72	
025050332	R1- 1-19	36	
	R1- 1-73	38	
	R1- 4	38	
025060232	P - 3	32	
	K1- 1-62	20	
025060233	K1- 1-67	20	
	K2- 2-50	22	
	R1- 72	40	
	R3- 25-49	46	
	V - 38	58	
	V - 46	58	
	V - 56	58	
	V - 60	58	
	R4- 65	50	
	V - 117	60	
	025060236	W3- 7-3	68
	025080232	K1- 1-30	18
		K1- 1-34	18
		K1- 1-51	18
		K2- 2-13	22
K2- 2-18		22	
K2- 2-23		22	
K2- 2-3		22	
K2- 2-33		22	
K2- 2-37		22	
R2- 12-13		42	
R2- 12-19		42	
R3- 25-14		46	
R3- 25-3		46	
R3- 25-7		46	
U - 1-6		56	
V - 71	60		
025100236	K1- 1-41	18	

CODE	REF.NO.	PAGE	
025100236	K2 - 2-44	22	
	F - 35	8	
025680132	Z2 - 20-2-4	72	
025680232	F - 14	8	
	G - 26	10	
025710232	Z2 - 20-2-6	72	
	R1 - 1-28	36	
025750132	J - 1-10	16	
	J - 1-17	16	
	J - 1-4	16	
	M - 9-11	28	
	R1 - 1-24	36	
	R1 - 1-38	36	
	R2 - 12-71	44	
	R3 - 25-44	46	
	R3 - 25-89	48	
	R4 - 26-22	52	
	R4 - 26-4	52	
	R4 - 26-6	52	
	R4 - 37	50	
	V - 150	62	
	W2- 6-1-10	66	
028030242	W2- 6-1-8	66	
	W2- 6-2-10	66	
	W2- 6-2-8	66	
	W2- 6-9	66	
	W3- 7-9	68	
	M - 1-11	28	
	M - 1-5	28	
	M - 1-8	28	
	R2 - 12-42	42	
	R4 - 81	52	
	V - 18	58	
	V - 77	60	
	028040242	K1 - 1-3	18
		R1 - 1-14	36
		R1 - 1-87	38
R4 - 26-15		52	
W1- 4-1-9		64	
W1- 4-3		64	
W2- 6-4		66	
W4- 8-4		68	
028040243		L - 1-24	26
		R3 - 25-46	46
		K1 - 1-82	20
028040246		M - 5	28
		R1 - 42	38
		R1 - 48	40
		R3 - 25-54	46
	R3 - 25-60	48	
	R3 - 25-71	48	
	R3 - 25-74	48	
	R4 - 29-5	50	
	U - 1-24	56	
	V - 103	60	
	V - 52	58	
	V - 66	58	
	028050242	M - 11	28
		R1 - 1-42	36
		R1 - 1-46	36
R1 - 1-49		36	
R1 - 1-61		38	
R1 - 1-76		38	
R1 - 1-84		38	
R1 - 7		38	
R3 - 25-91		48	
W2 - 6-12		66	

CODE	REF.NO.	PAGE
028050242	W4- 8-16	68
028050243	E - 54	6
028050246	K1 - 1-17	18
	K1 - 1-25	18
	K1 - 1-47	18
	K1 - 1-70	20
	K1 - 1-74	20
	K2- 2-54	22
	K2- 2-59	24
	K2- 2-9	22
	P - 18	32
	P - 21	32
	R2- 12-30	42
	R2- 12-34	42
	R2- 12-38	42
	R2- 12-59	42
	R2- 12-64	44
	R2- 20	44
	R3- 25-21	46
	R3- 25-24	46
	R3- 25-41	46
	R4- 28	52
	R4- 32	50
	V - 22	58
	V - 34	58
	V - 5	58
	Z2 - 12-7-2	72
028060242	R1 - 1-18	36
	R1 - 1-72	38
	R1 - 1-91	38
	R1 - 5	38
028060243	P - 4	32
	U - 1-8-3-1	56
028060246	K1 - 1-61	20
	K1 - 1-66	20
	K2- 2-49	22
	R1 - 71	40
	R3- 25-50	46
	R3- 25-65	48
	V - 118	60
	V - 39	58
	V - 47	58
	V - 57	58
	V - 61	58
028080242	W3- 7-4	68
028080246	K1 - 1-29	18
	K1 - 1-33	18
	K1 - 1-50	18
	K2- 2-14	22
	K2- 2-19	22
	K2- 2-24	22
	K2- 2-32	22
	K2- 2-36	22
	K2- 2-4	22
	R2- 12-12	42
	R2- 12-18	42
	R3- 25-15	46
	R3- 25-4	46
	R3- 25-8	46
	U - 1-7	56
	V - 72	60
028100246	K1 - 1-42	18
	K2- 2-45	22
031452206	Z2 - 12-11-4	72
	Z2 - 12-2-2	72
032311306	L - 2	26
034311302	V - 152	62

CODE	REF.NO.	PAGE
034311302	V - 79	60
039411215	Z2 - 17-4	72
047301042	L - 1-16	26
047301242	M - 1-13	28
048020342	J - 1-7	16
048030342	K1 - 1-6	18
048040342	F - 31	8
	R2- 12-14	42
048050342	K1 - 1-45	18
	K2- 2-56	22
	V - 31	58
048060342	K2 - 2-20	22
	U - 1-27	56
048070342	K1 - 1-10	18
048120142	R1 - 1-33	36
050501406	Z2 - 12-7-5	72
050503006	Z2 - 12-7-4	72
052400806	J - 1-19	16
	K1 - 1-53	18
	N - 7	30
	Q - 22	34
	U - 1-15	56
	U - 1-18	56
060660512	L - 1-14	26
060670612	G - 121	12
061020506	R2- 12-57	42
061400402	X - 1-12	70
061401205	X - 1-14	70
	X - 1-3	70
062060806	V - 81	60
	Z2 - 12-2-1	72
062300416	R3- 25-87	48
	R4- 74	52
062300512	R4- 26-21	52
062300616	J - 1-15	16
	J - 1-9	16
	L - 1-29	26
	M - 9-10	28
	R1 - 1-23	36
	R1- 1-37	36
	V - 16	58
062300806	V - 148	62
062301605	R2- 12-70	44
062302505	W3- 7-8	68
062302506	R4- 36	50
062304006	R3- 25-43	46
062400616	J - 1-12	16
062400812	R4- 26-7	52
062401006	L - 1-25	26
	P - 41	32
	V - 140	60
062500812	W2- 6-11	66
062501006	Z2 - 12-11-2	72
062501406	Z2 - 12-4-2	72
062670512	B - 27	2
	G - 102	12
	G - 21	10
	G - 23	10
	G - 83	12
	H - 4	14
062670712	E - 33	6
062670812	C - 1-6-1	4
	E - 24	6
	G - 3	10
062671012	E - 31	6
062680616	Q - 21	34
062680812	A - 3	2

CODE	REF.NO.	PAGE
062680812	G - 79	10
	H - 6	14
	Z2- 20-2-3	72
062681612	S - 7	54
062711012	F - 29	8
	G - 25	10
	S - 2	54
062711212	G - 11	10
062712012	R3- 25-84	48
	Z2- 20-2-1	72
062751612	E - 4	6
062761212	J - 1-23	16
062781412	G - 130	12
062782512	F - 3	8
072600480	D - 6-2	4
073010002	R1- 1-8	36
073050002	K1- 1-19	18
081030070	G - 27	10
100032003	T - 3	54
100064002	H - 2	14
100136001	L - 1-21	26
100197002	F - 4	8
100250001	B - 7	2
100251001	B - 12	2
	D - 5-2	4
100260001	E - 12-1	6
	E - 46-1	6
100360003	W4- 8-11	68
100401001	L - 1-20	26
100463001	V - 127	60
100645003	S - 8	54
100666002	Z2- 20-2-5	72
100887001	Z1- 17	70
101073001	V - 92	60
101572101	Z2- 4	72
101706001	B - 11	2
102731004	C - 1-4	4
104821009	G - 31	10
	G - 97	12
	V - 145	60
107780001	Z1- 16	70
108254001	H - 1-3	14
108265009	H - 1-5	14
108266001	H - 7	14
108802001	G - 64	10
108960002	F - 26	8
	H - 10	14
110087001	V - 129	60
110161006	F - 13	8
110233001	R3- 25-85	48
110563001	E - 20	6
	E - 6	6
111140002	R1- 50	40
111191001	G - 96	12
111942001	L - 1-12	26
111943001	L - 1-13	26
112293001	G - 124	12
	G - 61	10
112525000	R1- 1-69-2	38
112573101	B - 1	2
112574000	B - 6	2
112576001	B - 13	2
112577101	B - 9	2
112586001	B - 17	2
112588101	C - 1-1	4
112590001	C - 1-3	4
112593001	C - 1-7	4

CODE	REF.NO.	PAGE
112594001	C - 2	4
112658001	H - 8	14
112684001	D - 5-1	4
112700001	F - 27-1	8
112709001	H - 3	14
112712001	H - 1-8	14
112715001	H - 9	14
112717001	G - 10	10
112719001	G - 14	10
112720101	G - 15	10
112721001	C - 1-8	4
112728001	G - 56	10
112734001	G - 38	10
112735000	G - 58	10
112751003	E - 35	6
112753001	G - 40	10
112758009	G - 95	12
113014000	B - 10	2
113024000	B - 25	2
113050001	E - 44	6
113362001	G - 41	10
113431002	S - 3	54
113653000	G - 59	10
114483002	Z2- 19	72
114486002	Z2- 18	72
114693001	G - 57	10
114859001	U - 1-9	56
114909000	V - 24	58
114941001	H - 11	14
114967001	V - 128	60
115157001	Z1- 9	70
115585001	E - 48	6
116795000	G - 125	12
117466000	Z2- 6	72
117934009	K2- 2-46	22
118064001	Z1- 11	70
118320001	H - 1-7	14
118837001	Z2- 3	72
119706001	U - 1-2	56
119707003	U - 1-3	56
119708001	U - 1-4	56
119709003	U - 1-1-2	56
122991001	Z2- 1	72
126863001	Z2- 12-10	72
131007001	D - 5-3	4
131226001	F - 40	8
133172003	V - 155	62
133792101	U - 1-8-3	56
140527001	H - 13-1	14
140620001	E - 52	6
140682001	K1- 1-72-3	20
	K2- 2-57-3	24
	P - 15-3	32
	P - 19-3	32
	W3- 7-7-3	68
140890009	G - 30	10
141032000	Z1- 2	70
141256001	Z2- 15	72
141598001	R2- 12-66	44
142002001	Z1- 14	70
142027001	V - 126	60
142205001	Z1- 18	70
142268001	G - 20	10
142274009	G - 32	10
	G - 33	10
142443001	Z2- 2	72
142721001	Z1- 12	70











CODE	REF.NO.	PAGE
143489001	K1 - 1-80-5	20
143531000	W1- 4-1-7-1	64
143625001	E - 19	6
	E - 5	6
143626000	E - 7	6
143627000	E - 9	6
143637001	E - 21-1	6
143641001	E - 37	6
143642101	E - 38	6
143646000	E - 21-2	6
143669000	G - 48	10
143676000	G - 126	12
143679000	G - 120	12
143936000	G - 123	12
144504001	J - 1-21-3	16
144680001	H - 1-1	14
144682001	H - 1-4	14
144685001	H - 1-15	14
144686001	H - 1-16	14
144687001	H - 1-17	14
144688001	H - 1-18	14
144689001	H - 1-19	14
145446001	H - 1-11	14
	L - 1-19	26
145571101	L - 1-18	26
146080009	W1- 4-1-7-2	64
146141001	B - 8	2
146197001	L - 1-22	26
146253000	G - 92	12
146354001	R2- 12-60	44
146427001	T - 1-1	54
146536001	G - 101	12
147843001	U - 1-26	56
147926000	K1 - 1-80-2	20
147933001	K1 - 1-58	20
148005001	F - 12	8
148394000	G - 29	10
148539101	E - 40	6
148555001	R1 - 1-81	38
148762001	G - 37	10
148821001	D - 6-3	4
	D - 9	4
149066001	W1- 4-1-7-3	64
149069101	W1- 4-1-3	64
149070009	W1- 4-1-4	64
149320001	N - 8	30
149342001	K1 - 1-31	18
	K2 - 2-34	22
149487001	K1 - 1-39	18
	K2 - 2-42	22
149488001	K1 - 1-40	18
	K2 - 2-43	22
149547000	W1- 4-5	64
149566009	H - 1-14	14
149796001	P - 5	32
149799000	G - 132	12
149809000	K1 - 1-83	20
	P - 37	32
	V - 144	60
150106003	Z2 - 12-4	72
150172003	Z2 - 12-3	72
150173003	Z2 - 12-4-1	72
150174000	Z2 - 12-5	72
150179002	Z2 - 12-7-1	72
150180001	Z2 - 12-8	72
150182000	Z2 - 12-9	72
150188009	Z2 - 12-11-1	72







CODE	REF.NO.	PAGE
150189109	Z2 - 12-1	72
150191001	V - 82-3	60
150206002	V - 82-2	60
150335001	Z1 - 10	70
150349001	V - 136	60
150553003	H - 13-2	14
150756009	V - 153	62
150967101	F - 11	8
150988001	G - 9	10
151027001	F - 23-1-1-1	8
151029001	F - 23-2-2	8
151030001	F - 23-2-3	8
151163001	K2- 2-22	22
151439002	G - 131	12
151604001	E - 1-1	6
151927001	G - 35	10
152356301	L - 1-1	26
152357101	L - 1-2	26
152358001	L - 1-5	26
152361001	L - 1-10	26
152362001	L - 1-11	26
152363001	L - 1-15	26
152364001	L - 1-17	26
152565000	N - 1-1-7	30
152566000	N - 1-1-8	30
152645001	L - 1-28	26
152651301	L - 1	26
152974001	G - 128	12
152997001	E - 49	6
153009001	C - 1-5	4
153011011	A - 4	2
153011016	A - 4	2
	Z2 - 7	72
153011018	A - 4	2
153012101	C - 3	4
153015001	E - 1	6
153020001	E - 39	6
153024000	G - 122	12
153242000	Z1 - 4	70
153252000	P - 6	32
153274001	K1 - 1-72-4	20
	K2 - 2-57-4	24
	P - 15-4	32
	P - 19-4	32
153920001	G - 71	10
154024001	L - 1-7	26
154092001	L - 1-8	26
154125001	Z1 - 13	70
154560001	J - 1-21-4	16
154702001	Z2 - 11	72
155055001	W1- 4-2	64
155479001	F - 23-2-1	8
155491001	H - 1-2	14
156070002	G - 75	10
156096000	W2- 6-7-4	66
156292001	R1 - 1-94	38
156557001	F - 42	8
158115001	B - 18	2
	D - 7-1	4
158597001	L - 1-31	26
158769001	H - 1-9	14
159150009	A - 9	2
159384009	Z2 - 10	72
159386001	V - 113	60
159436001	F - 32	8
159732001	W2- 6-1-4	66
	W2- 6-2-4	66

CODE	REF.NO.	PAGE
159802001	F - 23-2-5	8
159805001	H - 1-12	14
159812001	V - 112-1	60
180157001	B - 14	2
183377001	J - 1-21	16
183387009	U - 1-1-1	56
183400009	Z2 - 17	72
183480009	Z2 - 20	72
183677001	E - 12	6
183699001	E - 21	6
215083001	L - 1-4	26
217093001	X - 1-11	70
219225000	N - 1-1-6	30
	Z1 - 5	70
233225001	X - 1-9	70
233229001	X - 1-7	70
233230001	X - 1-8	70
233231001	X - 1-10	70
	X - 1-2	70
233232001	X - 1-5	70
233233001	X - 1-4	70
233236001	X - 1-17	70
233250001	X - 1-15	70
237950001	S - 1	54
522990001	W1- 4-1-5	64
552851001	L - 1-27-2	26
552907000	P - 40	32
554482000	P - 38	32

ゲージ部品一覧表/GAUGE PARTS LIST/LEHREN LISTE
LISTE DES PIÈCES DECARTEMENT/LISTA DE PIEZAS CALIBRADORAS

No. 1

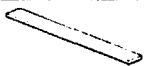

品名 Name of Parts	参照番号 Ref. No.	個数 Q'ty	針 巾 Needle Gauge								
			8 m/m	10m/m	12m/m	14m/m	16m/m	18m/m	20m/m		
糸切り Thread Trimmer	上糸切り移動刃 Needle Thread Trimmer Movable Knife 	M-6	1	ウワイトメス 8~12 Needle Thread Knife (8~12) (S08403-001)			ウワイトメス 14~16 Needle Thread Knife (14~16) (S10527-001)		ウワイトメス 18~20 Needle Thread Knife (18~20) (S10552-001)		
	上糸切り固定刃 Needle Thread Trimmer Fixed Knife 	M-7	1	コテイハ 8~12 Fixed Knife (8~12) (S08399-001)			コテイハ 14~16 Fixed Knife (14~16) (S10528-001)		コテイハ 18~20 Fixed Knife (18~20) (S10553-001)		
	上糸切り糸保持バネ Needle Thread Trimmer Thread Retainer Spring 	M-8	1	イトホジバネ 8~12 Thread Retainer Spring (8~12) (S08401-001)			イトホジバネ 14~16 Thread Retainer Spring (14~16) (S10529-001)		イトホジバネ 18~20 Thread Retainer Spring (18~20) (S10554-001)		
	下糸切りリンク Lower Thread Trimmer Link 	M-12	1	リンクB Link (B) (S08385-001)	リンクB Link (B) (S08385-002)	リンクB Link (B) (S08385-003)	リンクB Link (B) (S08385-004)	リンクB Link (B) (S08385-005)	リンクB Link (B) (S08385-006)	リンクB Link (B) (S08385-007)	
コーナーメス Corner Knife	台 Base 	R1-44	2	メスダイ 8クミ Knife Base Ass. 8 (S11521-001)	メスダイ 10クミ Knife Base Ass. 10 (S11522-001)	メスダイ 12クミ Knife Base Ass. 12 (S11523-001)	メスダイ 14クミ Knife Base Ass. 14 (S11524-001)	メスダイ 16クミ Knife Base Ass. 16 (S11525-001)	メスダイ 18クミ Knife Base Ass. 18 (S11526-001)	メスダイ 20クミ Knife Base Ass. 20 (S11527-001)	
	刃 (右側) Right Knife 	R1-52	2	コーナーメスSR Corner Knife (S-Right) (S08322-001)				コーナーメスLR Corner Knife (L-Right) (S08416-001)			
	刃 (左側) Left Knife 	R1-53	2	コーナーメスSL Corner Knife (S-Left) (S08302-001)				コーナーメスLL Corner Knife (L-Left) (S08417-001)			
バインダー・片玉 Binder・Single Welting		R3-68	1	オリコミイタオサエ Folding Plate Supporter (S11520-001)							
		R3-69	2	+ サラネジ 3×5 Screw 3×5 (004300-513)							
大押え調節ゲージ Carriage Feed Adjusting Gauge		R3-58	1	イドウダイスパーサ Movable Base Spacer (S08513-001)	イドウダイスパーサ Movable Base Spacer (S08513-002)	イドウダイスパーサ Movable Base Spacer (S08513-003)	イドウダイスパーサ Movable Base Spacer (S08513-004)	イドウダイスパーサ Movable Base Spacer (S08513-005)	イドウダイスパーサ Movable Base Spacer (S08513-006)	イドウダイスパーサ Movable Base Spacer (S08513-007)	
		R3-59	1	オオオサエゲージ Adjust Gauge (S08512-001)	オオオサエゲージ Adjust Gauge (S08512-002)	オオオサエゲージ Adjust Gauge (S08512-003)	オオオサエゲージ Adjust Gauge (S08512-004)	オオオサエゲージ Adjust Gauge (S08512-005)	オオオサエゲージ Adjust Gauge (S08512-006)	オオオサエゲージ Adjust Gauge (S08512-007)	

品名 Name of Parts			参照番号 Ref. No.	個数 Q'ty	針 市 Needle Gauge						
					8 m/m	10m/m	12m/m	14m/m	16m/m	18m/m	20m/m
スベータ Spacer	大押え用 For Carriage Feed	スベータS Spacer (S) 	R3-56	2	t=6 (S08510-101)	t=5 (S08510-102)	t=4 (S08510-103)	t=3 (S08510-104)	t=2 (S08510-105)	t=1 (S08510-106)	
		スベータW Spacer (W) 	R3-57	2	t=3.5 (S08511-101)	t=4.5 (S08511-102)	t=5.5 (S08511-103)	t=6.5 (S08511-104)	t=7.5 (S08511-105)	t=8.5 (S08511-106)	t=9.5 (S08511-107)
生地滑り板 Cloth Slide Plate	右側 Right 	V-141	1	キジスベリイタR Slide Plate (Right) (S31229-001)			キジスベリイタR Slide Plate (Right) (S31229-002)		キジスベリイタR Slide Plate (Right) (S31229-003)		
	左側 Left 	V-142	1	キジスベリイタL Slide Plate (Left) (S31230-001)			キジスベリイタL Slide Plate (Left) (S31230-002)		キジスベリイタL Slide Plate (Left) (S31230-003)		
頭部 Machine Head	針抱き組 Needle Clamp Ass. 	T-1	1	ハリダキ8クミ Needle Clamp Ass. 8 (S09335-001)	ハリダキ10クミ Needle Clamp Ass. 10 (158810-001)	ハリダキ12クミ Needle Clamp Ass. 12 (158811-001)	ハリダキ14クミ Needle Clamp Ass. 14 (S09466-001)	ハリダキ16クミ Needle Clamp Ass. 16 (S09336-001)	ハリダキ18クミ Needle Clamp Ass. 18 (S09468-001)	ハリダキ20クミ Needle Clamp Ass. 20 (S09337-001)	
	針板 Needle Plate 	T-2	1	ハリイタ8 Needle Plate 8 (S09461-001)	ハリイタ10 Needle Plate 10 (153022-001)	ハリイタ12 Needle Plate 12 (158060-001)	ハリイタ14 Needle Plate 14 (S09462-001)	ハリイタ16 Needle Plate 16 (S09463-001)	ハリイタ18 Needle Plate 18 (S09464-001)	ハリイタ20 Needle Plate 20 (S09465-001)	

品名 Name of Parts		参照番号 Ref. No.	個数 Q'ty	t=2 m/m	t=3 m/m	t=4 m/m	t=5 m/m	t=6 m/m
オオオサエゴム Carriage Feed Rubber 		R3-55	2	S08267-002	S08267-003	S08267-004	S08267-005	S08267-006

バインダー / Binder

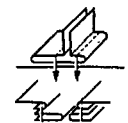
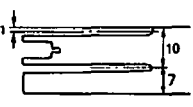
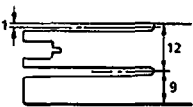
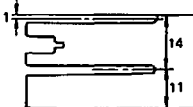
用途 Usage	参照番号 Ref. No.	個数 Q'ty	針 巾 / Needle Gauge						
			8 m/m	10m/m	12m/m	14m/m	16m/m	18m/m	20m/m
両玉繰縫い Double Welting	R2-54	1							
			ジョウギクミ 8W Binder Assembly 8W (S14709-009)	ジョウギクミ 10W Binder Assembly 10W (S14713-009)	ジョウギクミ 12W Binder Assembly 12W (S14717-009)	ジョウギクミ 14W Binder Assembly 14W (S14721-009)	ジョウギクミ 16W Binder Assembly 16W (S14725-009)	ジョウギクミ 18W Binder Assembly 18W (S14729-009)	ジョウギクミ 20W Binder Assembly 20W (S14733-009)
	T-7	1	—			—	—	—	—
			B ジョウギクミ 10W B Binder Assembly 10W (S18577-009)	B ジョウギクミ 12W B Binder Assembly 12W (S18579-009)	—	—	—	—	
片玉繰縫い Single Welting	R2-54	1							
			ジョウギクミ 8S Binder Assembly 8S (S14711-009)	ジョウギクミ 10S Binder Assembly 10S (S14715-009)	ジョウギクミ 12S Binder Assembly 12S (S14719-009)	ジョウギクミ 14S Binder Assembly 14S (S14723-009)	ジョウギクミ 16S Binder Assembly 16S (S14727-009)	ジョウギクミ 18S Binder Assembly 18S (S14731-009)	ジョウギクミ 20S Binder Assembly 20S (S14735-009)
	T-7	1			—	—	—	—	—
			B ジョウギクミ 8S B Binder Assembly 8S (S30515-009)	B ジョウギクミ 10S B Binder Assembly 10S (S30479-009)	—	—	—	—	—
片玉繰縫い Single Welting	T-6	1							
			C ジョウギクミ 8S C Binder Assembly 8S (S18906-009)	C ジョウギクミ 10S C Binder Assembly 10S (S18908-009)	C ジョウギクミ 12S C Binder Assembly 12S (S18793-009)	C ジョウギクミ 14S C Binder Assembly 14S (S18910-009)	C ジョウギクミ 16S C Binder Assembly 16S (S18912-009)	C ジョウギクミ 18S C Binder Assembly 18S (S18914-009)	C ジョウギクミ 20S C Binder Assembly 20S (S18916-009)
逆玉繰縫い Overlapped Single Welting	T-8	1	—	—	—	—	—		
			D ジョウギクミ 18S D Binder Assembly 18S (S18795-009)	D ジョウギクミ 20S D Binder Assembly 20S (S18797-009)	—	—	—	—	—

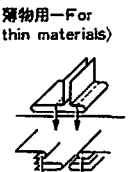
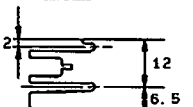
用途 Usage		参照番号 Ref. No.	個数 Q'ty	針 巾 / Needle Gauge						
				8 m/m	10m/m	12m/m	14m/m	16m/m	18m/m	20m/m
オフセット五線縫い Off-set Welting 		T-5	1	—	 OF ジョウギクミ Off-set Binder Assembly (S15602-008)	 OF ジョウギクミ Off-set Binder Assembly (S15604-008)	 OF ジョウギクミ Off-set Binder Assembly (S15606-008)	—	—	—
		T-5	1	—	 OF ジョウギクミ Off-set Binder Assembly (S23737-008)	—	—	—	—	—
	(薄物用—For thin materials) 	T-5	1	—	 OF-B ジョウギクミ Off-set B Binder Assembly (S23738-008)	—	—	—	—	—

brother

ブラザー工業株式会社

〒467 名古屋市瑞穂区河岸一丁目1番1号
TEL (052) 824-2392代

BROTHER INDUSTRIES LTD. MIYATOYA JAPAN

151-605, 606
S98605-001 ①
1993, 07

Printed in Japan / Gedrukt in Japan / Imprimé au Japon / Impreso en Japón

From the library of Superior Sewing Machine & Supply LLC